

1 No. BEAM

REQUIRED AS DRAWN MARKED BM1

SHOP MATERIAL LIST FOR 1 ASSEMBLY						
Mark	Size	Grade	No.	Length (mm)	Area (m ²)	Weight (kg)
BM1	UB254*146*37	S275	1	4314	4.694	158.2
a2	RSA125*75*8	S275	2	4057	3.252	97.8
p11	FLT10*150	S275	1	241	0.080	2.8
Total					8.026	258.9

GENERAL NOTES

All Holes to be **22** Dia UNO Slot hole length is to outside
 All Welds to be **6** FW. UNO

All Steelwork Manufactured to:
 BS EN 1090-2: Execution Class **EXC2** U.N.O.

FINISH **S.B. & PRIME**
 LOT **0** QTY **1**
 PHASE **1** QTY **1**

FABRICATION STATUS

Sawn by: _____ Date: _____
 Fabricated by: _____ Date: _____
 Welded by: _____ Date: _____
 Loaded by: _____ Date: _____
 Checked by: _____ Date: _____

A	ISSUED FOR APPROVAL	REV			
		By	Date	By	Date
	PCS	25.01.2023	SK	25.01.2023	
MARK	DESCRIPTION	CREATED	CHECKED		

CLIENT: Ebenezzer Street
DATE CREATED: 31.12.2022

PROJECT: Ebenezzer Street
DRAWN BY: PCS

CONTRACT NO: T8298
DRAWING NO: [BM.1]
REV: A

ASSEMBLY / SUB ASSEMBLY STATUS	
1	THIS IS IT'S OWN ASSEMBLY

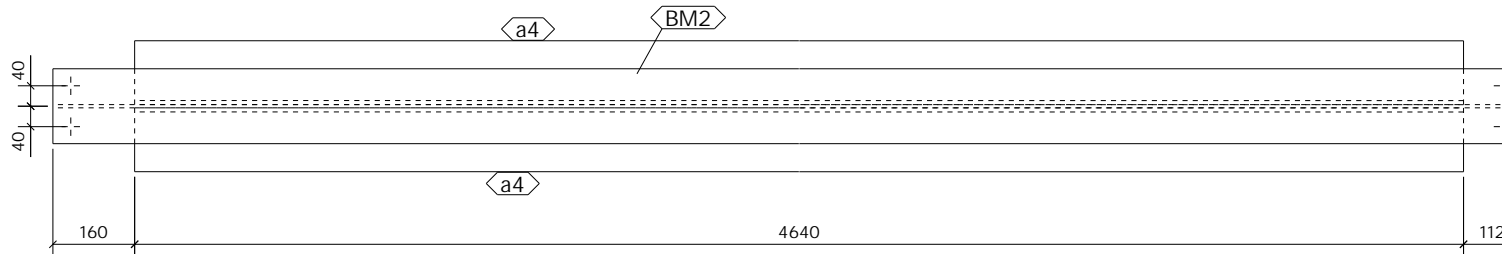

TOP VIEW
1:10

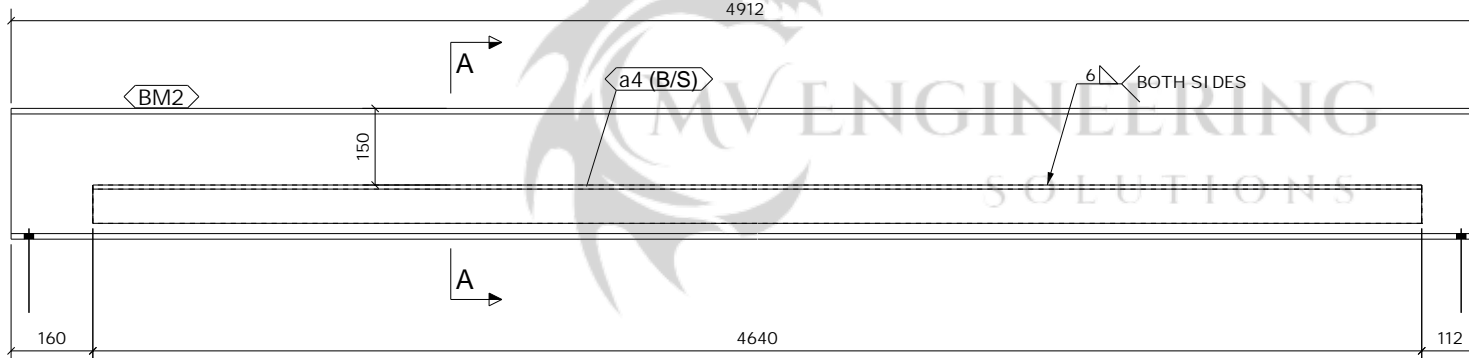

FRONT VIEW
1:10

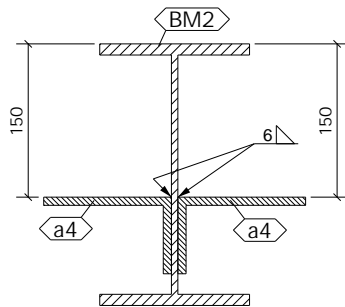

A - A

1 No. BEAM

REQUIRED AS DRAWN MARKED BM2

SHOP MATERIAL LIST FOR 1 ASSEMBLY

Mark	Size	Grade	No.	Length (mm)	Area (m ²)	Weight (kg)
BM2	UB254*146*37	S275	1	4912	5.343	180.1
a4	RSA125*75*8	S275	2	4640	3.718	111.9
Total					9.062	292.0

GENERAL NOTES

All Holes to be 22 Dia UNO Slot hole length is to outside
All Welds to be 6 FW. UNO

All Steelwork Manufactured to:
BS EN 1090-2: Execution Class **EXC2** U.N.O.

FINISH **S.B. & PRIME**
LOT **0** QTY **1**
PHASE **1** QTY **1**

FABRICATION STATUS

Sawn by: _____ Date: _____
Fabricated by: _____ Date: _____
Welded by: _____ Date: _____
Loaded by: _____ Date: _____
Checked by: _____ Date: _____

REV	DESCRIPTION	ISSUED FOR APPROVAL			
		By	Date	By	Date
A		PCS	25.01.2023	SK	25.01.2023
MARK		CREATED		CHECKED	

CLIENT: Ebenezzer Street DATE CREATED: 31.12.2022

PROJECT: Ebenezzer Street DRAWN BY: PCS

CONTRACT NO: T8298 DRAWING NO: [BM.2] REV: A

ASSEMBLY / SUB ASSEMBLY STATUS	
1	THIS IS IT'S OWN ASSEMBLY

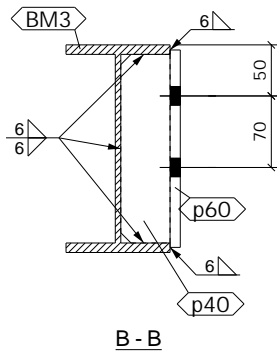
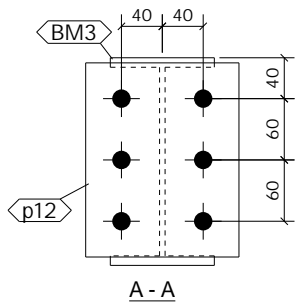
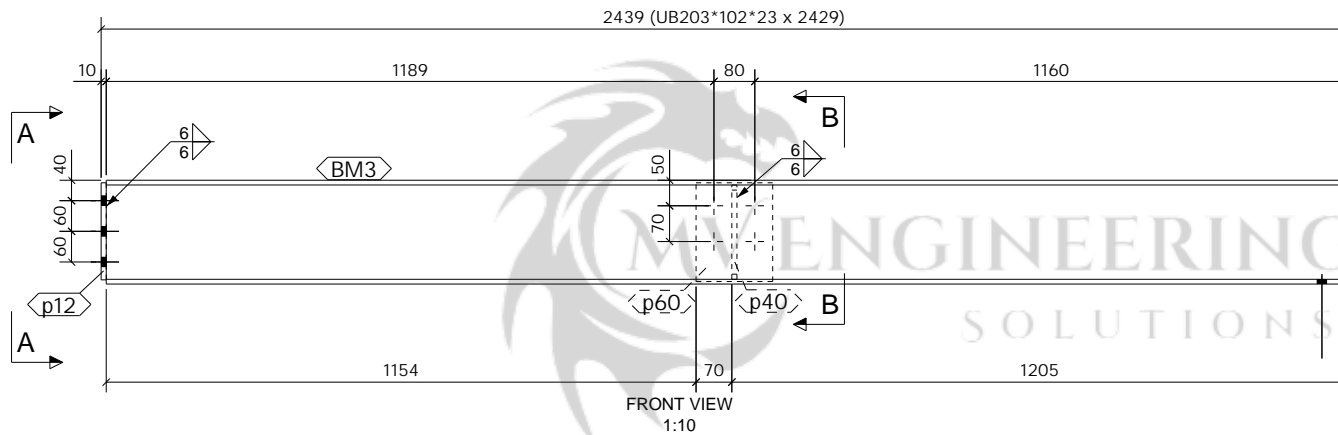
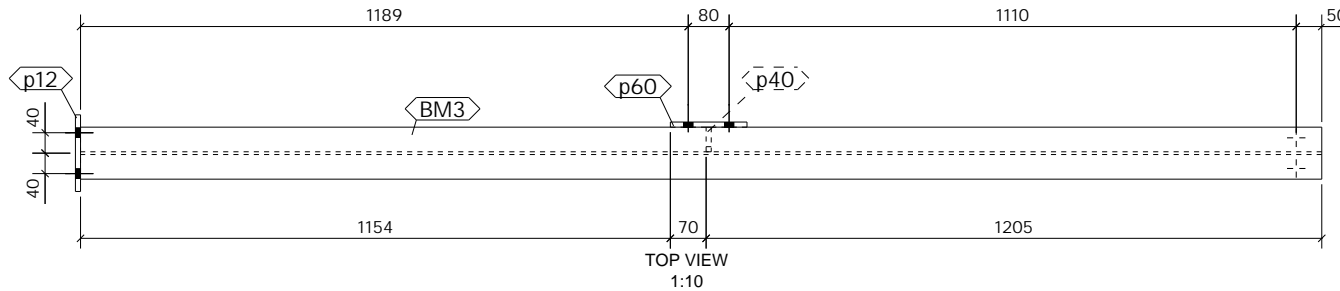

1 No. BEAM

REQUIRED AS DRAWN MARKED BM3

SHOP MATERIAL LIST FOR 1 ASSEMBLY

Mark	Size	Grade	No.	Length (mm)	Area (m ²)	Weight (kg)
BM3	UB203*102*23	S275	1	2429	1.956	55.1
p12	FLT10*150	S275	1	190	0.064	2.2
p40	PLT10*48.2	S275	1	185	0.022	0.7
p60	FLT10*150	S275	1	193	0.065	2.3
Total					2.107	60.3

GENERAL NOTES

All Holes to be **22 Dia UNO** Slot hole length is to outside
 All Welds to be **6 FW. UNO**

All Steelwork Manufactured to:
 BS EN 1090-2: Execution Class **EXC2** U.N.O.

FINISH **S.B. & PRIME**
 LOT **0** QTY **1**
 PHASE **1** QTY **1**

FABRICATION STATUS

Sawn by: _____ Date: _____
 Fabricated by: _____ Date: _____
 Welded by: _____ Date: _____
 Loaded by: _____ Date: _____
 Checked by: _____ Date: _____

REV	DESCRIPTION	ISSUED FOR APPROVAL			
		By	Date	By	Date
A		PCS	25.01.2023	SK	25.01.2023
MARK		CREATED		CHECKED	

CLIENT: Ebenezzer Street **DATE CREATED:** 23.01.2023

PROJECT: Ebenezzer Street **DRAWN BY:** PCS

CONTRACT NO: T8298 **DRAWING NO:** [BM.3] **REV:** A

ASSEMBLY / SUB ASSEMBLY STATUS	
1	THIS IS IT'S OWN ASSEMBLY

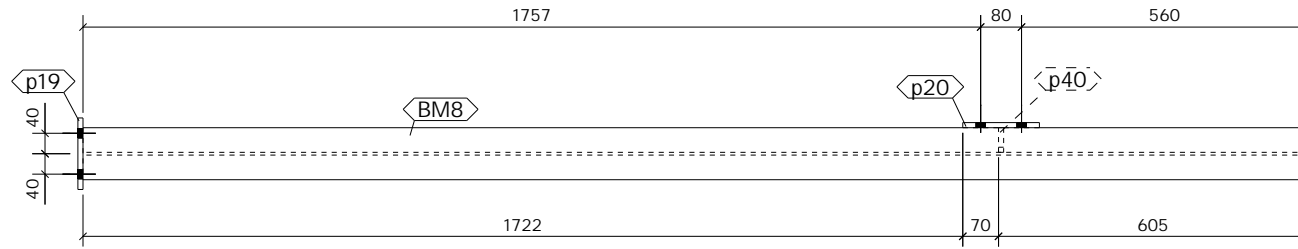

TOP VIEW
1:10

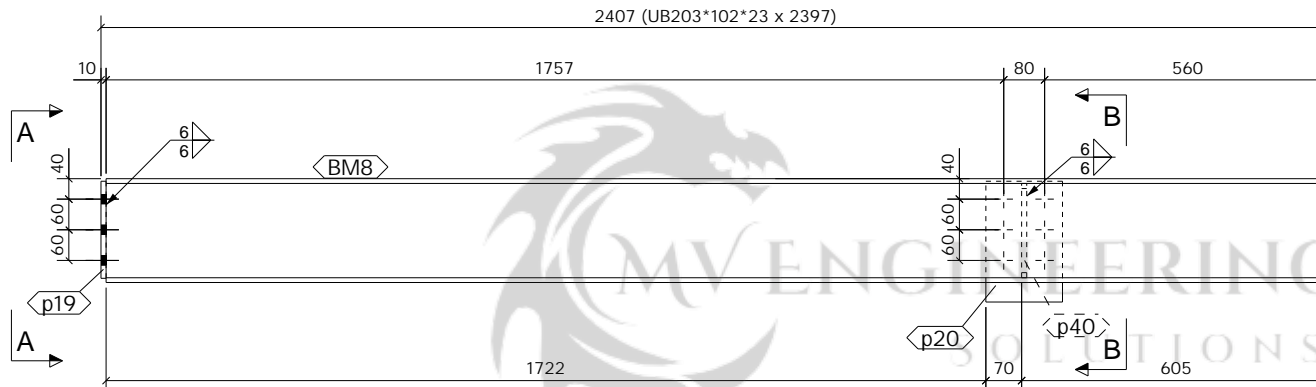

FRONT VIEW
1:10

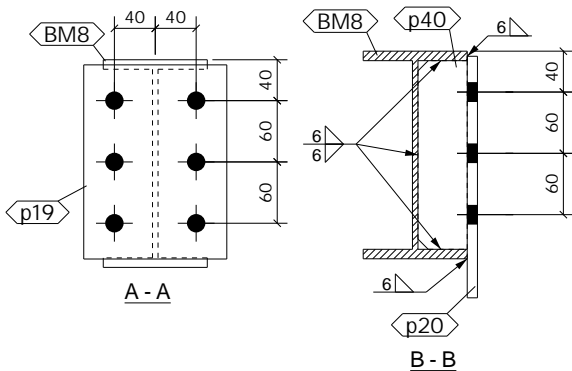

1 No. BEAM

REQUIRED AS DRAWN MARKED BM4

SHOP MATERIAL LIST FOR 1 ASSEMBLY

Mark	Size	Grade	No.	Length (mm)	Area (m ²)	Weight (kg)
BM8	UB203*102*23	S275	1	2397	1.930	54.4
p19	FLT10*140	S275	1	190	0.060	2.1
p20	FLT10*150	S275	1	236	0.079	2.8
p40	PLT10*48.2	S275	1	185	0.022	0.7
Total					2.091	59.9

GENERAL NOTES

All Holes to be **22** Dia UNO Slot hole length is to outside
 All Welds to be **6** FW. UNO

All Steelwork Manufactured to:
 BS EN 1090-2: Execution Class **EXC2** U.N.O.

FINISH **S.B. & PRIME**
 LOT **0** QTY **1**
 PHASE **1** QTY **1**

FABRICATION STATUS

Sawn by: _____ Date: _____
 Fabricated by: _____ Date: _____
 Welded by: _____ Date: _____
 Loaded by: _____ Date: _____
 Checked by: _____ Date: _____

A	ISSUED FOR APPROVAL	By		Date	
		PCS	SK	25.01.2023	25.01.2023
REV	DESCRIPTION	By	Date	By	Date
MARK	DESCRIPTION	CREATED	CHECKED		

CLIENT: _____ DATE CREATED: 23.01.2023

PROJECT: Ebenezer Street DRAWN BY: PCS

CONTRACT NO: T8298 DRAWING NO: [BM.4] REV: A

ASSEMBLY / SUB ASSEMBLY STATUS	
1	THIS IS IT'S OWN ASSEMBLY

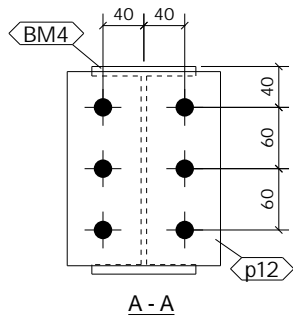
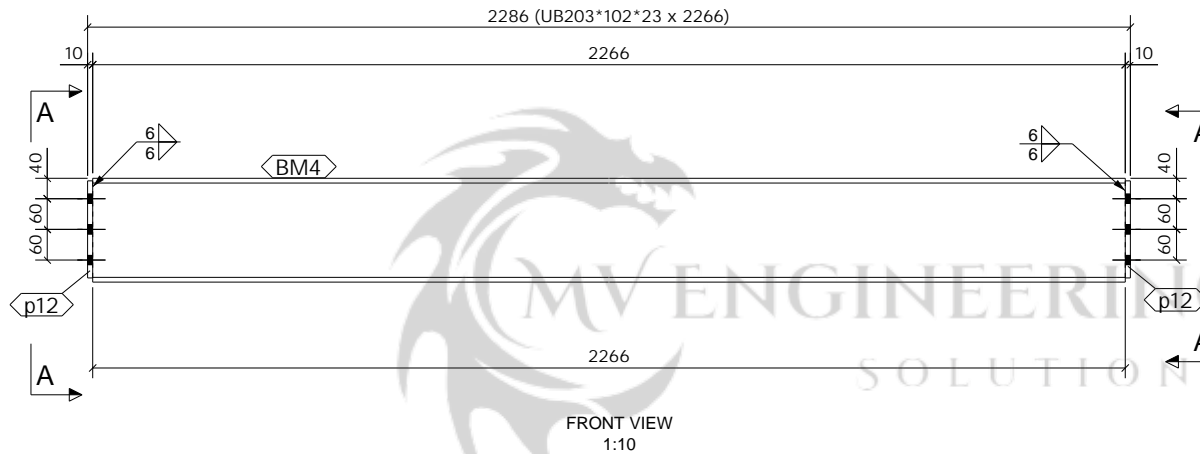
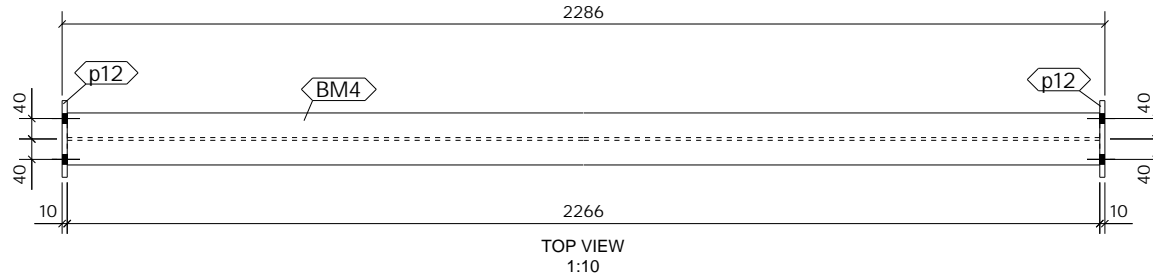

SHOP MATERIAL LIST FOR 1 ASSEMBLY

Mark	Size	Grade	No.	Length (mm)	Area (m ²)	Weight (kg)
BM4	UB203*102*23	S275	1	2266	1.825	51.4
p12	FLT10*150	S275	2	190	0.128	4.5
				Total	1.953	55.9

GENERAL NOTES

All Holes to be **22** Dia UNO Slot hole length is to outside
 All Welds to be **6** FW. UNO

All Steelwork Manufactured to:
 BS EN 1090-2: Execution Class **EXC2** U.N.O.

FINISH **S.B. & PRIME**
 LOT **0** QTY **1**
 PHASE **1** QTY **1**

FABRICATION STATUS

Sawn by: _____ Date: _____
 Fabricated by: _____ Date: _____
 Welded by: _____ Date: _____
 Loaded by: _____ Date: _____
 Checked by: _____ Date: _____

A	ISSUED FOR APPROVAL	REV			
		By	Date	By	Date
	PCS	25.01.2023	SK	25.01.2023	
MARK	DESCRIPTION	CREATED	CHECKED		

CLIENT: _____ **DATE CREATED:** 23.01.2023

PROJECT: Ebenezer Street **DRAWN BY:** PCS

CONTRACT NO: T8298 **DRAWING NO:** [BM.5] **REV:** A

1 No. BEAM

REQUIRED AS DRAWN MARKED **BM5**

ASSEMBLY / SUB ASSEMBLY STATUS	
1	THIS IS IT'S OWN ASSEMBLY

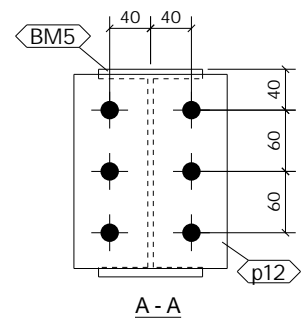
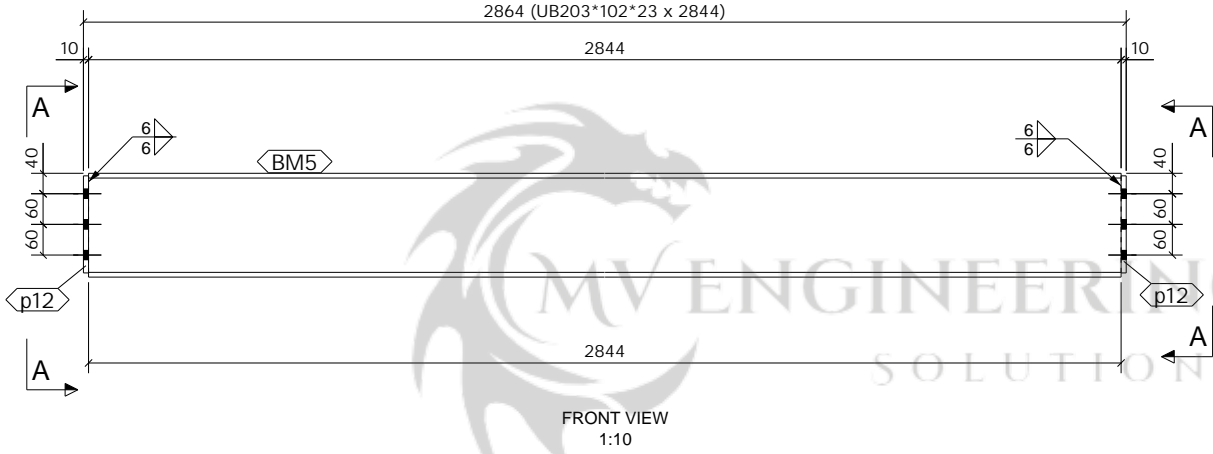
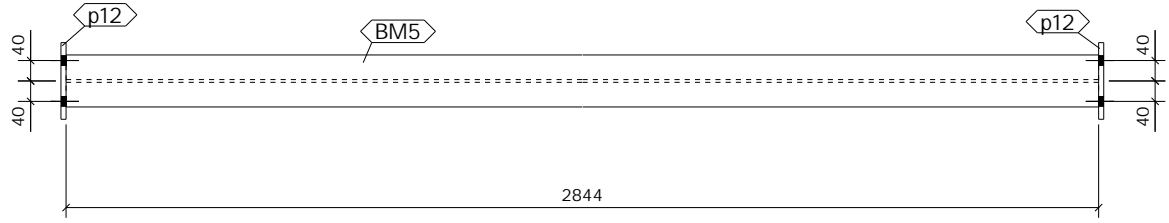

2 No. BEAM

REQUIRED AS DRAWN MARKED BM6

SHOP MATERIAL LIST FOR 1 ASSEMBLY

Mark	Size	Grade	No.	Length (mm)	Area (m ²)	Weight (kg)
BM5	UB203*102*23	S275	1	2844	2.289	64.5
p12	FLT10*150	S275	2	190	0.128	4.5
				Total	2.416	69.0

GENERAL NOTES

All Holes to be **22** Dia UNO Slot hole length is to outside
 All Welds to be **6** FW. UNO

All Steelwork Manufactured to:
 BS EN 1090-2: Execution Class **EXC2** U.N.O.

FINISH **S.B. & PRIME**
 LOT **0** QTY **2**
 PHASE **1** QTY **2**

FABRICATION STATUS

Sawn by: _____ Date: _____
 Fabricated by: _____ Date: _____
 Welded by: _____ Date: _____
 Loaded by: _____ Date: _____
 Checked by: _____ Date: _____

A	ISSUED FOR APPROVAL	PCS	25.01.2023	SK	25.01.2023
REV		By	Date	By	Date
MARK	DESCRIPTION	CREATED	CHECKED		

CLIENT: _____ **DATE CREATED:** 23.01.2023

PROJECT: Ebenezer Street **DRAWN BY:** PCS

CONTRACT NO: T8298 **DRAWING NO:** [BM.6] **REV:** A

ASSEMBLY / SUB ASSEMBLY STATUS	
2	THIS IS IT'S OWN ASSEMBLY

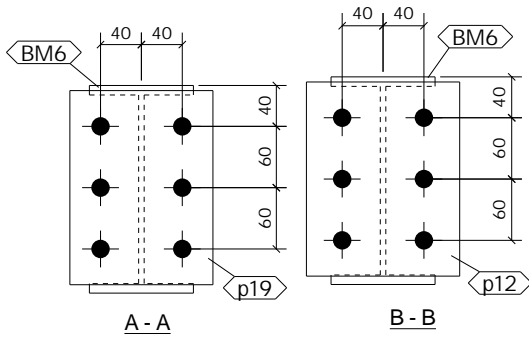
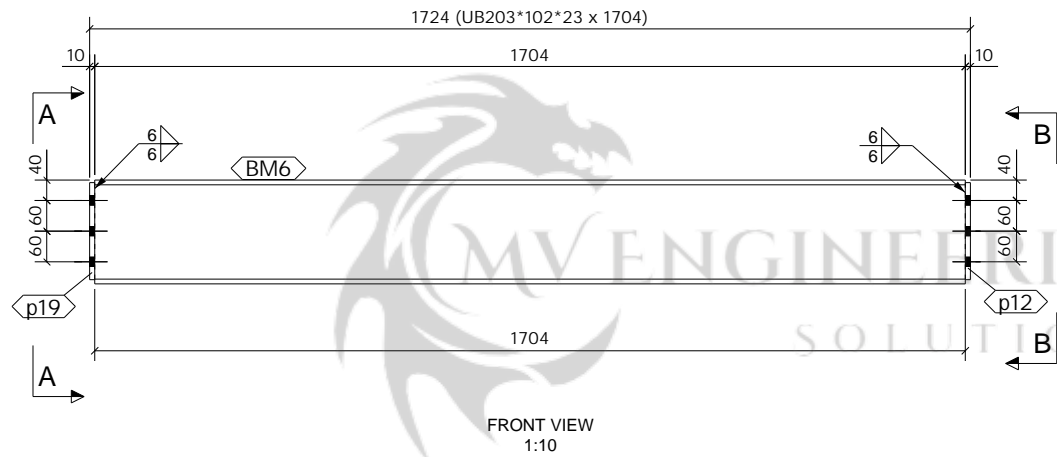
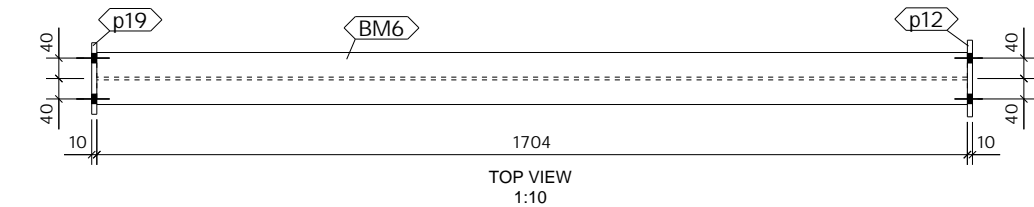

2 No. BEAM

REQUIRED AS DRAWN MARKED BM7

SHOP MATERIAL LIST FOR 1 ASSEMBLY

Mark	Size	Grade	No.	Length (mm)	Area (m ²)	Weight (kg)
BM6	UB203*102*23	S275	1	1704	1.374	38.7
p12	FLT10*150	S275	1	190	0.064	2.2
p19	FLT10*140	S275	1	190	0.060	2.1
				Total	1.497	43.0

GENERAL NOTES

All Holes to be 22 Dia UNO Slot hole length is to outside
 All Welds to be 6 FW. UNO

All Steelwork Manufactured to:
 BS EN 1090-2: Execution Class **EXC2** U.N.O.

FINISH **S.B. & PRIME**
 LOT **0** QTY **2**
 PHASE **1** QTY **2**

FABRICATION STATUS

Sawn by: _____ Date: _____
 Fabricated by: _____ Date: _____
 Welded by: _____ Date: _____
 Loaded by: _____ Date: _____
 Checked by: _____ Date: _____

A	ISSUED FOR APPROVAL	APPROVAL			
		PCS	25.01.2023	SK	25.01.2023
REV	DESCRIPTION	By	Date	By	Date
MARK	DESCRIPTION	CREATED		CHECKED	

CLIENT: _____ **DATE CREATED:** 23.01.2023

PROJECT: Ebenezer Street **DRAWN BY:** PCS

CONTRACT NO: T8298 **DRAWING NO:** [BM.7] **REV:** A

ASSEMBLY / SUB ASSEMBLY STATUS	
2	THIS IS IT'S OWN ASSEMBLY

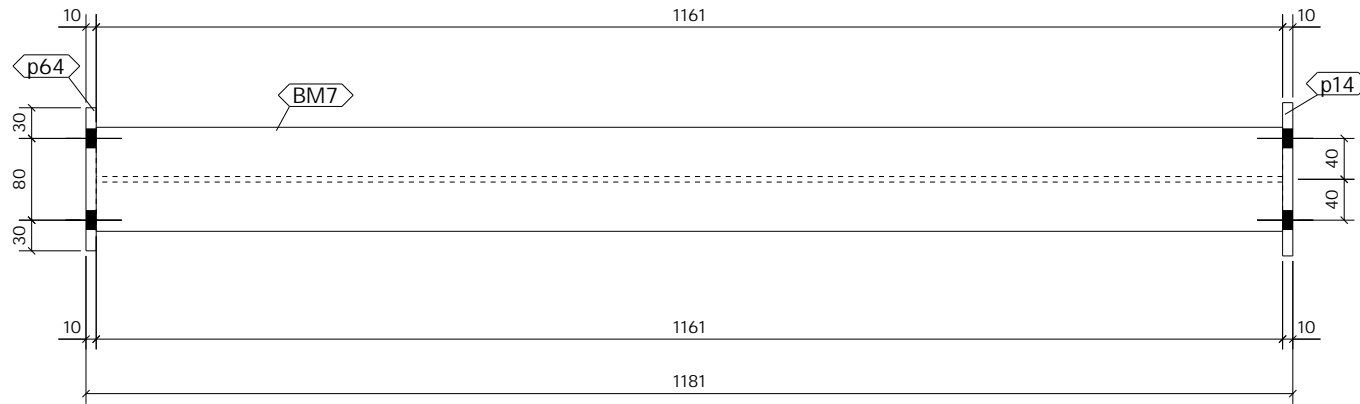

TOP VIEW
1:5

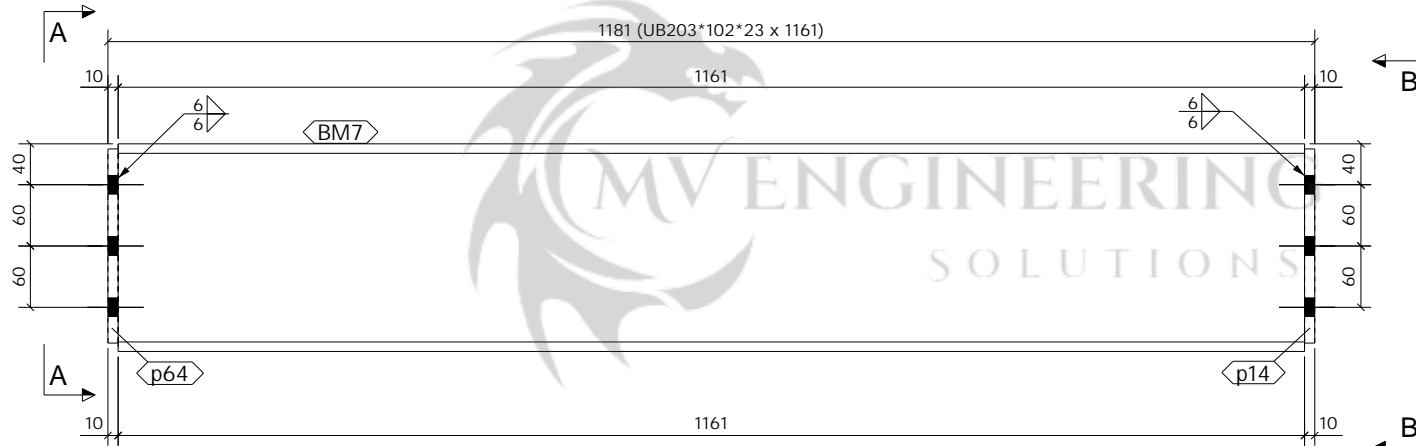

FRONT VIEW
1:5

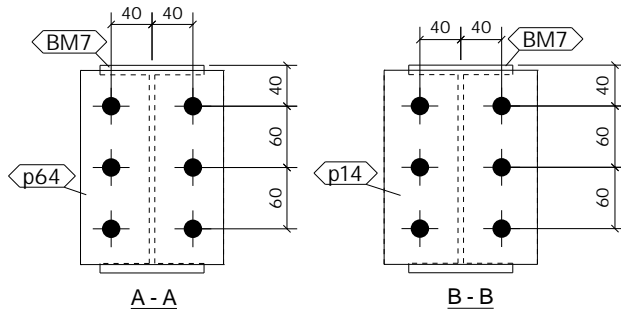

1 No. BEAM

REQUIRED AS DRAWN MARKED BM8

ASSEMBLY / SUB ASSEMBLY STATUS	
1	THIS IS IT'S OWN ASSEMBLY

SHOP MATERIAL LIST FOR 1 ASSEMBLY

Mark	Size	Grade	No.	Length (mm)	Area (m ²)	Weight (kg)
BM7	UB203*102*23	S275	1	1161	0.938	26.3
p14	FLT10*150	S275	1	190	0.064	2.2
p64	FLT10*140	S275	1	190	0.060	2.1
				Total	1.061	30.7

GENERAL NOTES

All Holes to be 22 Dia UNO Slot hole length is to outside
 All Welds to be 6 FW. UNO

All Steelwork Manufactured to:
 BS EN 1090-2: Execution Class **EXC2** U.N.O.

FINISH **GALVANISED**

LOT **0** QTY **1**

PHASE **1** QTY **1**

FABRICATION STATUS

Sawn by: _____ Date: _____

Fabricated by: _____ Date: _____

Welded by: _____ Date: _____

Loaded by: _____ Date: _____

Checked by: _____ Date: _____

A	ISSUED FOR APPROVAL	BY		DATE	
		PCS	SK	25.01.2023	25.01.2023
REV		By	Date	By	Date
MARK	DESCRIPTION	CREATED	CHECKED		

CLIENT: _____ DATE CREATED: 23.01.2023

PROJECT: Ebenezer Street DRAWN BY: PCS

CONTRACT NO: T8298 DRAWING NO: [BM.8] REV: A

SHOP MATERIAL LIST FOR 1 ASSEMBLY

Mark	Size	Grade	No.	Length (mm)	Area (m ²)	Weight (kg)
BM9	UB203*102*23	S275	1	507	0.413	11.5
p12	FLT10*150	S275	1	190	0.064	2.2
Total					0.477	13.7

GENERAL NOTES

All Holes to be **22** Dia UNO Slot hole length is to outside
 All Welds to be **6** FW. UNO

All Steelwork Manufactured to:
 BS EN 1090-2: Execution Class **EXC2** U.N.O.

FINISH **S.B. & PRIME**
 LOT **0** QTY **1**
 PHASE **1** QTY **1**

FABRICATION STATUS

Sawn by: _____ Date: _____
 Fabricated by: _____ Date: _____
 Welded by: _____ Date: _____
 Loaded by: _____ Date: _____
 Checked by: _____ Date: _____

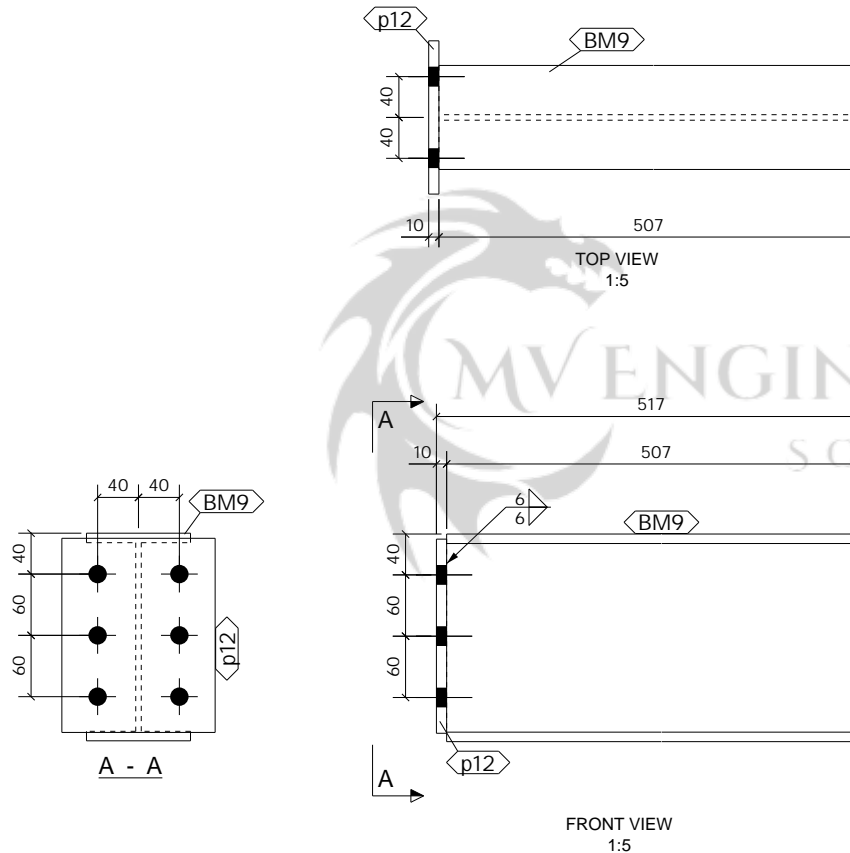

1 No. BEAM

REQUIRED AS DRAWN MARKED **BM9**

ASSEMBLY / SUB ASSEMBLY STATUS	
1	THIS IS IT'S OWN ASSEMBLY

A	ISSUED FOR APPROVAL	REV			
		By	Date	By	Date
	PCS	25.01.2023	SK	25.01.2023	
MARK	DESCRIPTION	CREATED	CHECKED		

CLIENT: _____ **DATE CREATED:** 23.01.2023

PROJECT: Ebenezer Street **DRAWN BY:** PCS

CONTRACT NO: T8298 **DRAWING NO:** [BM.9] **REV:** A

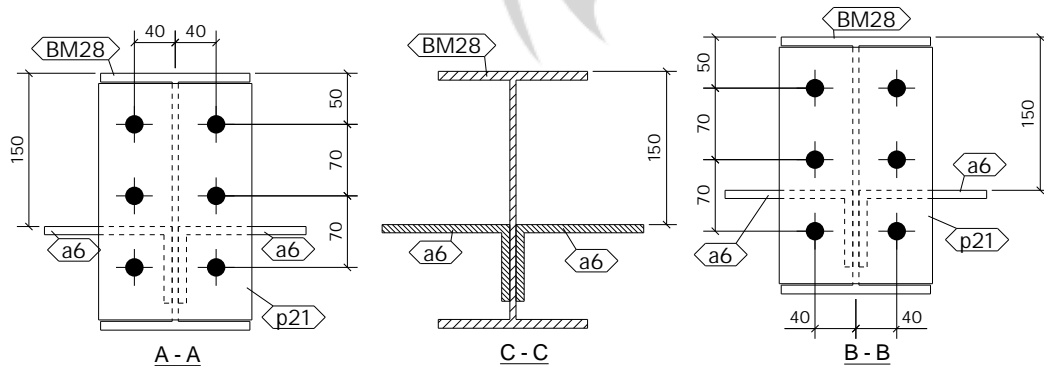
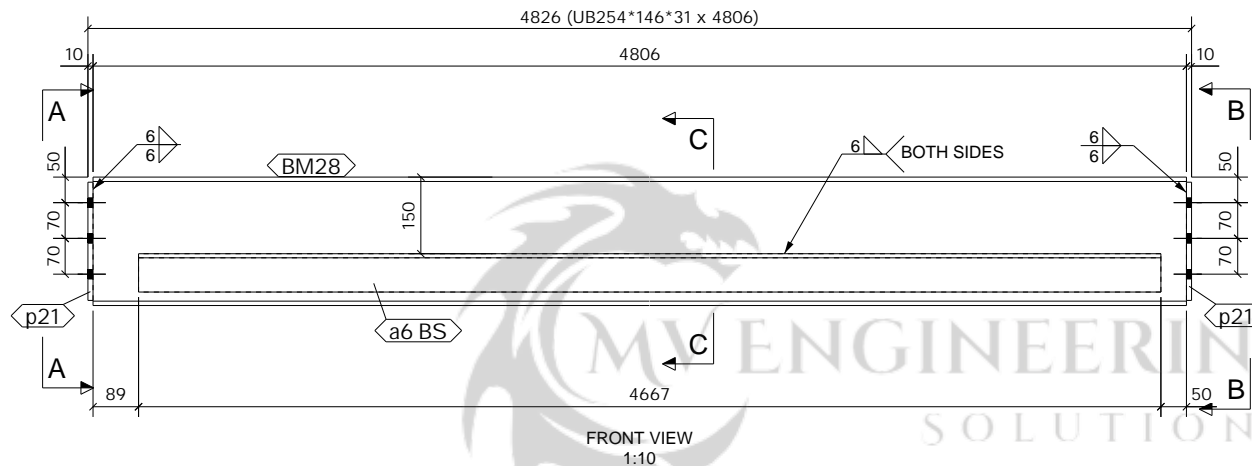
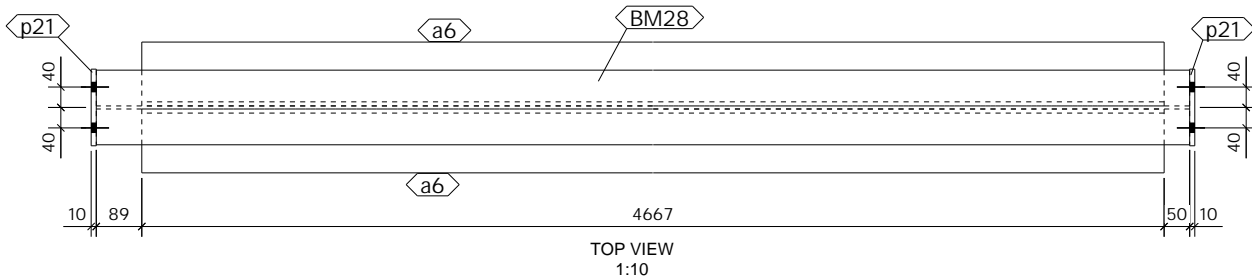

1 No. BEAM

REQUIRED AS DRAWN MARKED BM10

SHOP MATERIAL LIST FOR 1 ASSEMBLY

Mark	Size	Grade	No.	Length (mm)	Area (m ²)	Weight (kg)
BM28	UB254*146*31	S275	1	4806	5.175	147.8
a6	RSA125*75*8	S275	2	4667	3.739	112.5
p21	FLT10*150	S275	2	231	0.154	5.4
				Total	9.068	265.8

GENERAL NOTES

All Holes to be **22** Dia UNO Slot hole length is to outside
 All Welds to be **6** FW. UNO

All Steelwork Manufactured to:
 BS EN 1090-2: Execution Class **EXC2** U.N.O.

FINISH **S.B. & PRIME**
 LOT **0** QTY **1**
 PHASE **1** QTY **1**

FABRICATION STATUS

Sawn by: _____ Date: _____
 Fabricated by: _____ Date: _____
 Welded by: _____ Date: _____
 Loaded by: _____ Date: _____
 Checked by: _____ Date: _____

REV	DESCRIPTION	ISSUED FOR APPROVAL			
		By	Date	By	Date
A		PCS	25.01.2023	SK	25.01.2023
MARK		CREATED		CHECKED	

CLIENT: Ebenezzer Street **DATE CREATED:** 23.01.2023

PROJECT: Ebenezzer Street **DRAWN BY:** PCS

CONTRACT NO: T8298 **DRAWING NO:** [BM.10] **REV:** A

ASSEMBLY / SUB ASSEMBLY STATUS	
1	THIS IS IT'S OWN ASSEMBLY

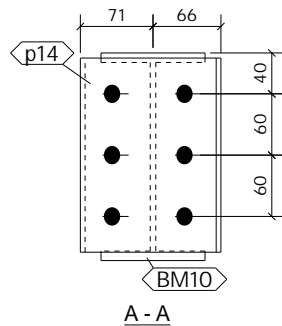
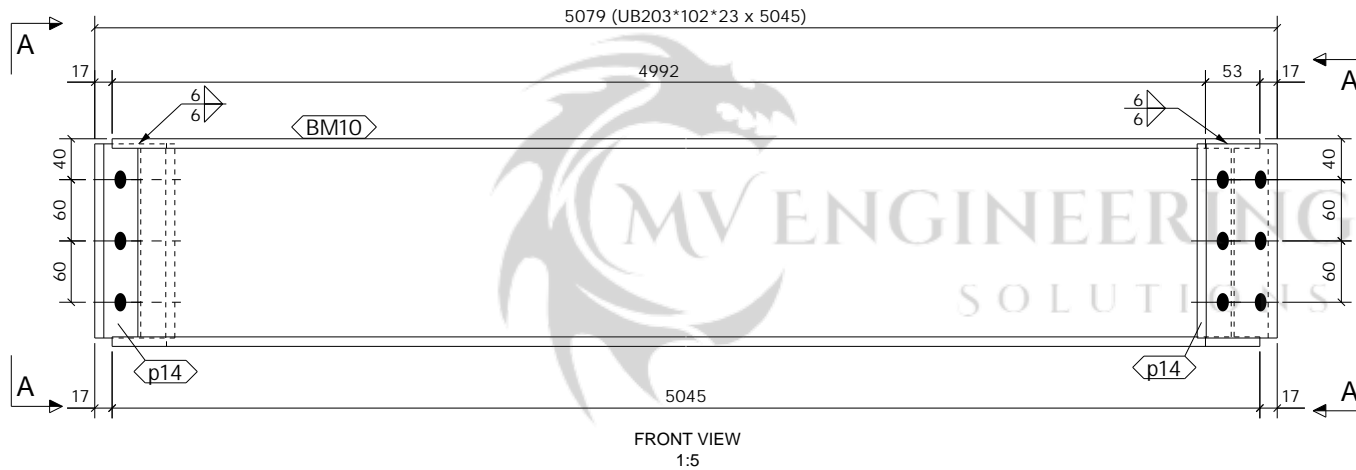
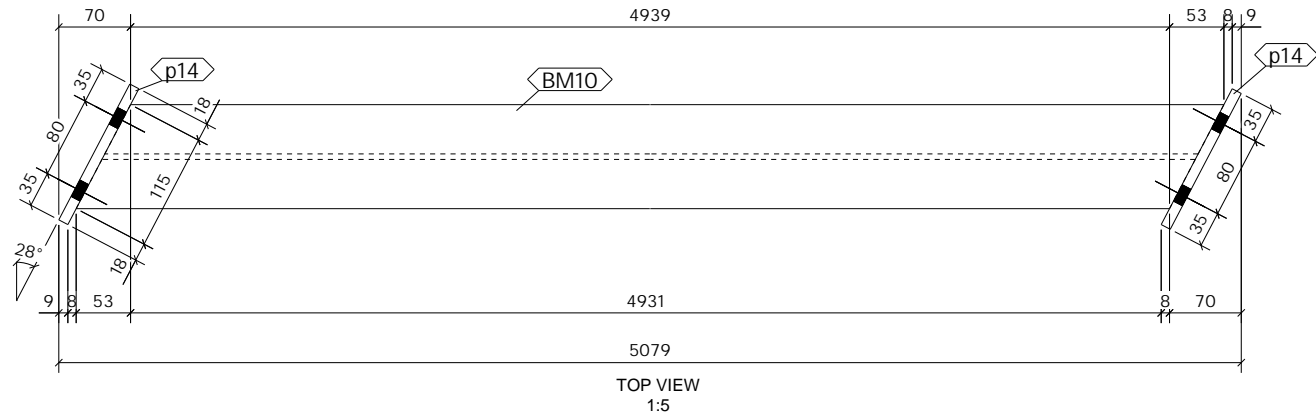

1 No. BEAM

REQUIRED AS DRAWN MARKED BM11

SHOP MATERIAL LIST FOR 1 ASSEMBLY

Mark	Size	Grade	No.	Length (mm)	Area (m ²)	Weight (kg)
BM10	UB203*102*23	S275	1	5045	4.014	113.3
p14	FLT10*150	S275	2	190	0.128	4.5
Total					4.142	117.7

GENERAL NOTES

All Holes to be **22** Dia UNO Slot hole length is to outside
 All Welds to be **6** FW. UNO

All Steelwork Manufactured to:
 BS EN 1090-2: Execution Class **EXC2** U.N.O.

FINISH **GALVANISED**
 LOT **0** QTY **1**
 PHASE **1** QTY **1**

FABRICATION STATUS

Sawn by: _____ Date: _____
 Fabricated by: _____ Date: _____
 Welded by: _____ Date: _____
 Loaded by: _____ Date: _____
 Checked by: _____ Date: _____

REV	MARK	DESCRIPTION	ISSUED FOR APPROVAL			
			By	Date	By	Date
	A		PCS	25.01.2023	SK	25.01.2023
			CREATED		CHECKED	

CLIENT: Ebenezzer Street **DATE CREATED:** 24.01.2023

PROJECT: Ebenezzer Street **DRAWN BY:** PCS

CONTRACT NO: T8298 **DRAWING NO:** [BM.11] **REV:** A

ASSEMBLY / SUB ASSEMBLY STATUS	
1	THIS IS IT'S OWN ASSEMBLY

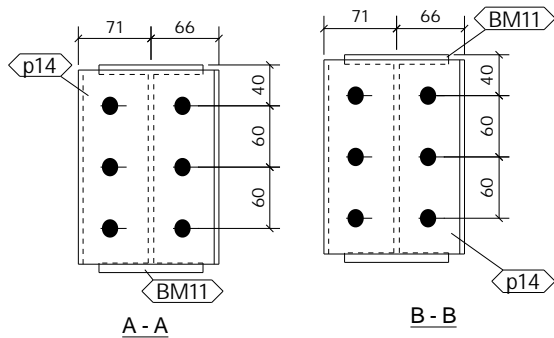
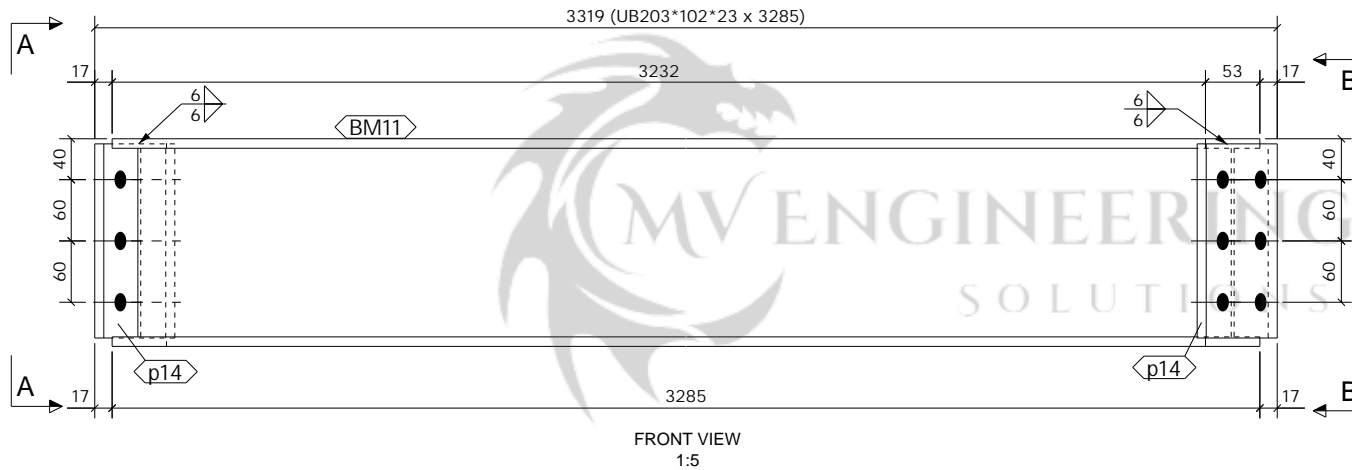
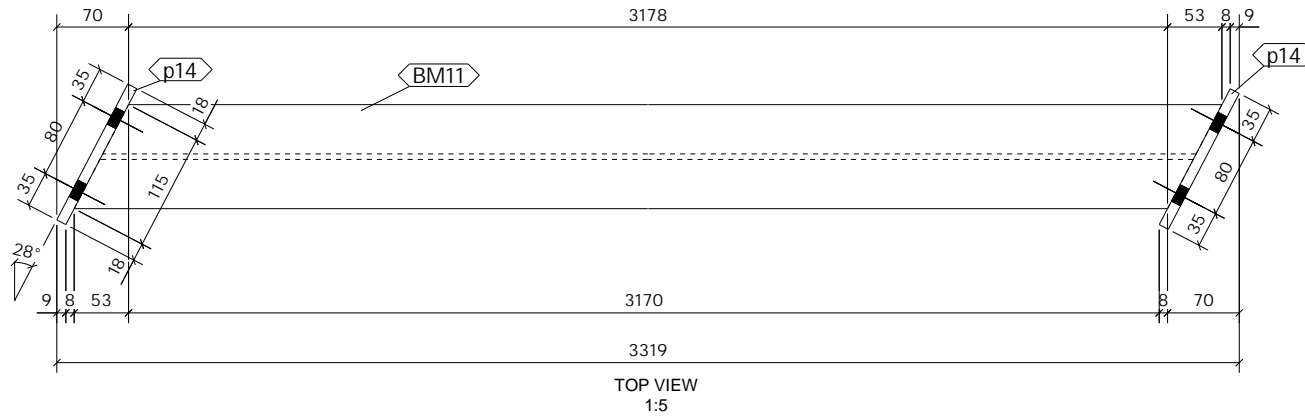

1 No. BEAM

REQUIRED AS DRAWN MARKED BM12

SHOP MATERIAL LIST FOR 1 ASSEMBLY

Mark	Size	Grade	No.	Length (mm)	Area (m ²)	Weight (kg)
BM11	UB203*102*23	S275	1	3285	2.601	73.3
p14	FLT10*150	S275	2	190	0.128	4.5
Total					2.728	77.8

GENERAL NOTES

All Holes to be **22** Dia UNO Slot hole length is to outside
 All Welds to be **6** FW. UNO

All Steelwork Manufactured to:
 BS EN 1090-2: Execution Class **EXC2** U.N.O.

FINISH **GALVANISED**
 LOT **0** QTY **1**
 PHASE **1** QTY **1**

FABRICATION STATUS

Sawn by: _____ Date: _____
 Fabricated by: _____ Date: _____
 Welded by: _____ Date: _____
 Loaded by: _____ Date: _____
 Checked by: _____ Date: _____

REV	DESCRIPTION	ISSUED FOR APPROVAL			
		By	Date	By	Date
A		PCS	25.01.2023	SK	25.01.2023
MARK		CREATED		CHECKED	

CLIENT: _____ DATE CREATED: 24.01.2023

PROJECT: Ebenezer Street DRAWN BY: PCS

CONTRACT NO: T8298 DRAWING NO: [BM.12] REV: A

ASSEMBLY / SUB ASSEMBLY STATUS	
1	THIS IS IT'S OWN ASSEMBLY

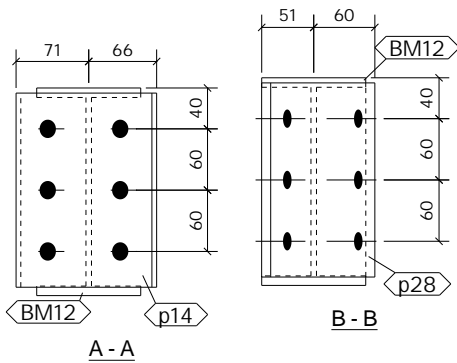
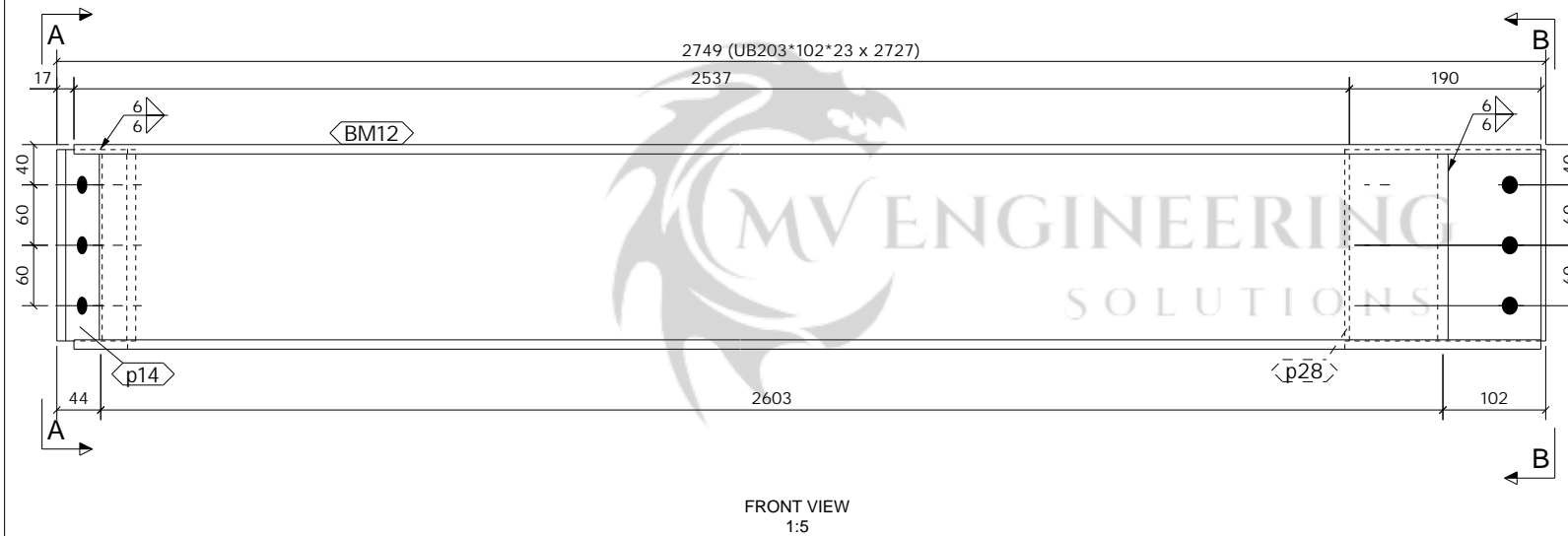
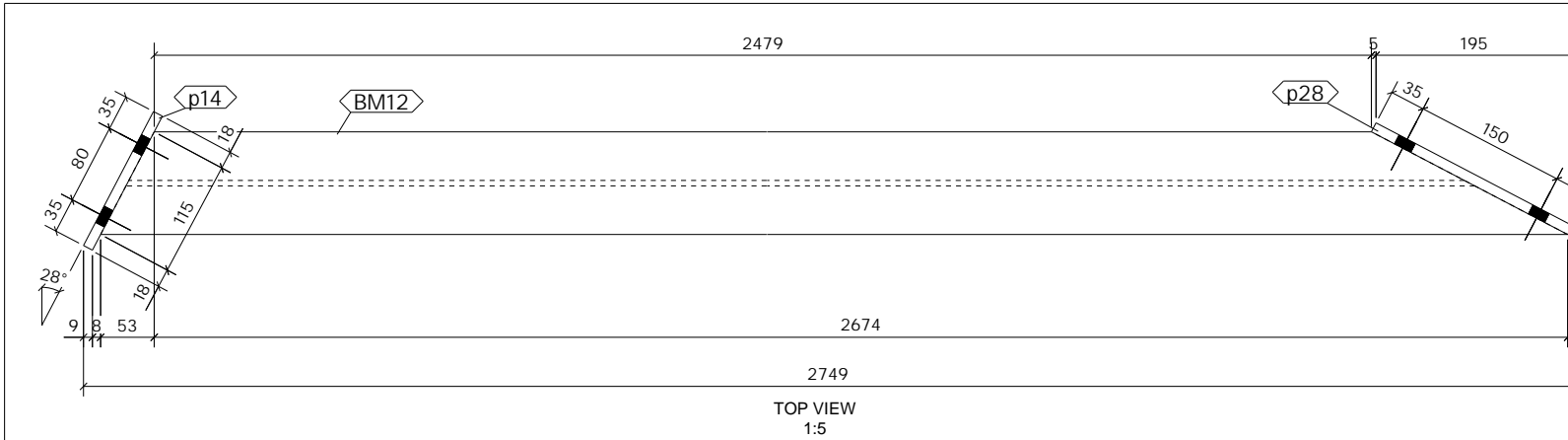

1 No. BEAM

REQUIRED AS DRAWN MARKED BM13

SHOP MATERIAL LIST FOR 1 ASSEMBLY

Mark	Size	Grade	No.	Length (mm)	Area (m ²)	Weight (kg)
BM12	UB203*102*23	S275	1	2727	2.099	59.1
p14	FLT10*150	S275	1	190	0.064	2.2
p28	FLT10*220	S275	1	190	0.092	3.3
Total					2.255	64.6

GENERAL NOTES

All Holes to be **22** Dia UNO Slot hole length is to outside
 All Welds to be **6** FW. UNO

All Steelwork Manufactured to:
 BS EN 1090-2: Execution Class **EXC2** U.N.O.

FINISH **GALVANISED**
 LOT **0** QTY **1**
 PHASE **1** QTY **1**

FABRICATION STATUS

Sawn by: _____ Date: _____
 Fabricated by: _____ Date: _____
 Welded by: _____ Date: _____
 Loaded by: _____ Date: _____
 Checked by: _____ Date: _____

REV	DESCRIPTION	ISSUED FOR APPROVAL			
		By	Date	By	Date
A		PCS	25.01.2023	SK	25.01.2023
MARK		CREATED		CHECKED	

CLIENT: Ebenezzer Street **DATE CREATED:** 23.01.2023

PROJECT: Ebenezzer Street **DRAWN BY:** PCS

CONTRACT NO: T8298 **DRAWING NO:** [BM.13] **REV:** A

ASSEMBLY / SUB ASSEMBLY STATUS	
1	THIS IS IT'S OWN ASSEMBLY

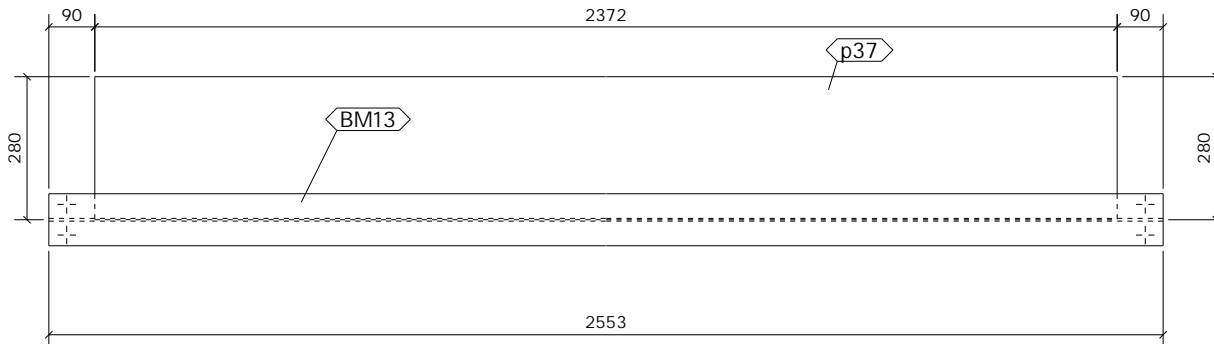

TOP VIEW
1:10

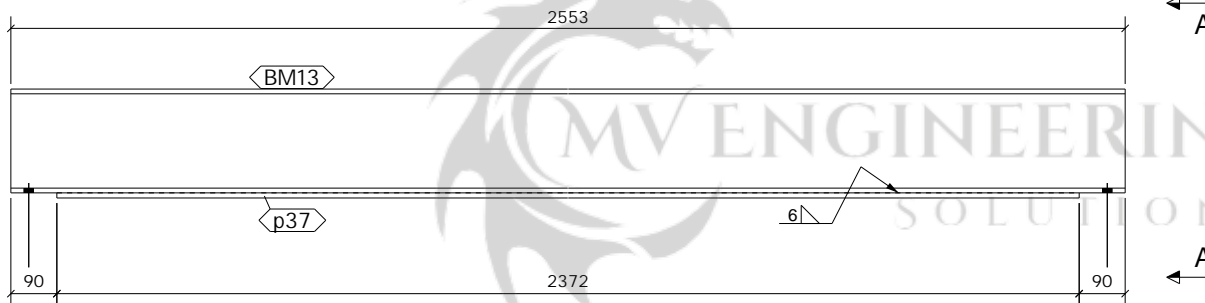

FRONT VIEW
1:10

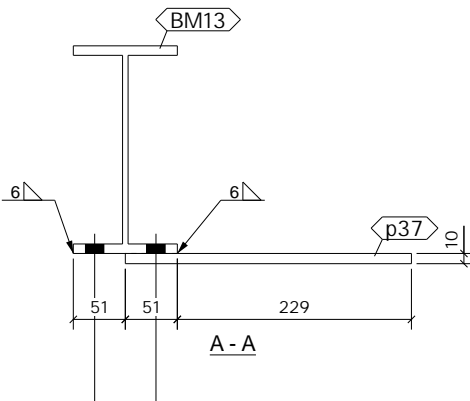

A - A

1 No. BEAM

REQUIRED AS DRAWN MARKED BM14

SHOP MATERIAL LIST FOR 1 ASSEMBLY

Mark	Size	Grade	No.	Length (mm)	Area (m ²)	Weight (kg)
BM13	UB203*102*23	S275	1	2553	2.055	57.9
p37	PL10*280	S275	1	2372	1.382	52.1
				Total	3.437	110.1

GENERAL NOTES

All Holes to be 22 Dia UNO Slot hole length is to outside
All Welds to be 6 FW. UNO

All Steelwork Manufactured to:
BS EN 1090-2: Execution Class **EXC2** U.N.O.

FINISH **S.B. & PRIME**
LOT **0** QTY **1**
PHASE **1** QTY **1**

FABRICATION STATUS

Sawn by: _____ Date: _____
Fabricated by: _____ Date: _____
Welded by: _____ Date: _____
Loaded by: _____ Date: _____
Checked by: _____ Date: _____

B	ISSUED FOR APPROVAL	PCS	01.02.2023	SK	01.02.2023
A	ISSUED FOR APPROVAL	PCS	25.01.2023	SK	25.01.2023
REV		By	Date	By	Date
MARK	DESCRIPTION	CREATED	CHECKED		

CLIENT: _____ DATE CREATED: 23.01.2023

PROJECT: Ebenezer Street DRAWN BY: PCS

CONTRACT NO: T8298 DRAWING NO: [BM.14] REV: B

ASSEMBLY / SUB ASSEMBLY STATUS	
1	THIS IS IT'S OWN ASSEMBLY

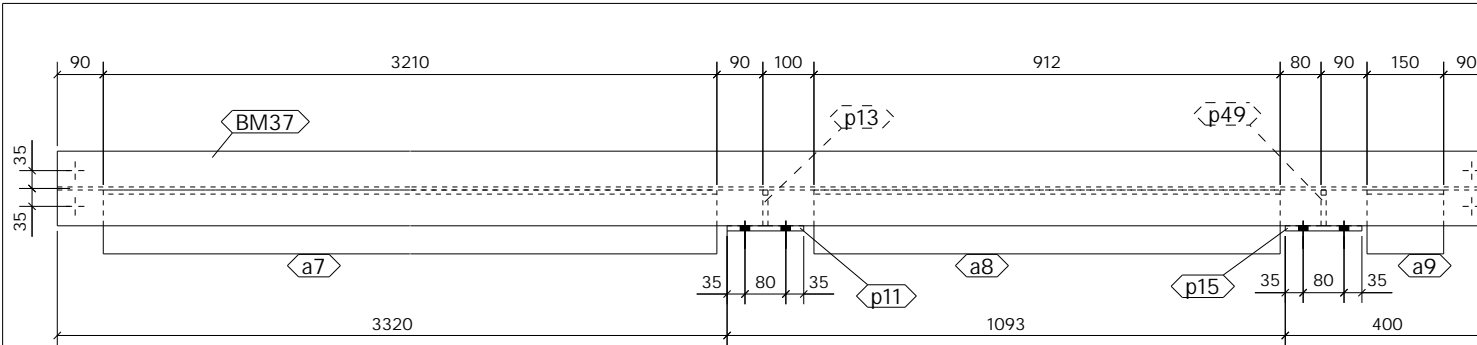

TOP VIEW
1:10

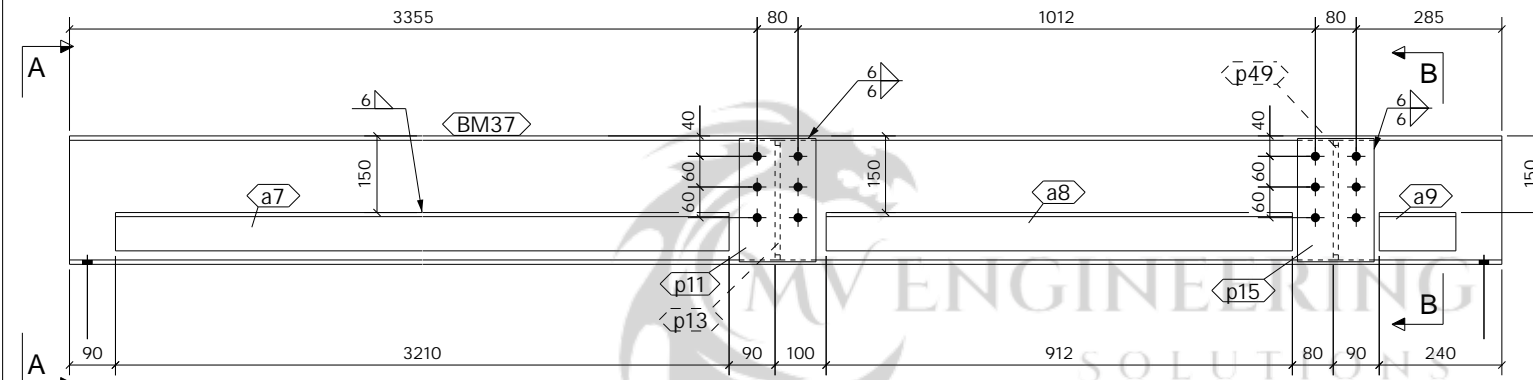

FRONT VIEW
1:10

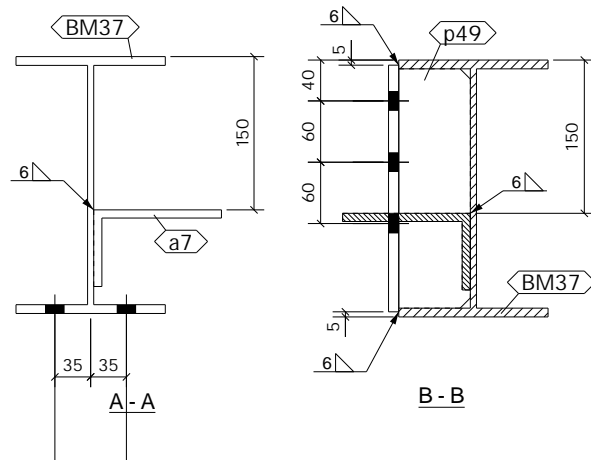

B - B

1 No. BEAM

REQUIRED AS DRAWN MARKED BM15

SHOP MATERIAL LIST FOR 1 ASSEMBLY

Mark	Size	Grade	No.	Length (mm)	Area (m ²)	Weight (kg)
BM37	UB254*146*31	S275	1	4813	5.182	148.0
a7	RSA125*75*8	S275	1	3210	1.287	38.7
a8	RSA125*75*8	S275	1	912	0.368	11.0
a9	RSA125*75*8	S275	1	150	0.063	1.8
p11	FLT10*150	S275	1	241	0.080	2.8
p13	FLT10*70	S275	1	234	0.039	1.3
p15	FLT10*150	S275	1	241	0.080	2.8
p49	FLT10*70	S275	1	234	0.039	1.3
				Total	7.138	207.8

GENERAL NOTES

All Holes to be 22 Dia UNO Slot hole length is to outside
 All Welds to be 6 FW. UNO

All Steelwork Manufactured to:
 BS EN 1090-2: Execution Class EXC2 U.N.O.

FINISH S.B. & PRIME
 LOT 0 QTY 1
 PHASE 1 QTY 1

FABRICATION STATUS

Sawn by: _____ Date: _____
 Fabricated by: _____ Date: _____
 Welded by: _____ Date: _____
 Loaded by: _____ Date: _____
 Checked by: _____ Date: _____

A	ISSUED FOR APPROVAL			
	PCS	25.01.2023	SK	25.01.2023
REV	By	Date	By	Date
MARK	DESCRIPTION	CREATED	CHECKED	

CLIENT: Ebenezzer Street DATE CREATED: 23.01.2023

PROJECT: Ebenezzer Street DRAWN BY: PCS

CONTRACT NO: T8298 DRAWING NO: [BM.15] REV: A

ASSEMBLY / SUB ASSEMBLY STATUS	
1	THIS IS IT'S OWN ASSEMBLY

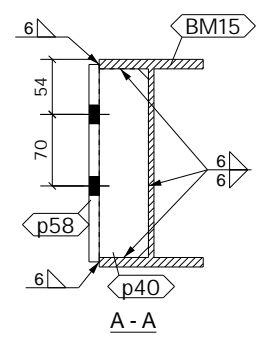
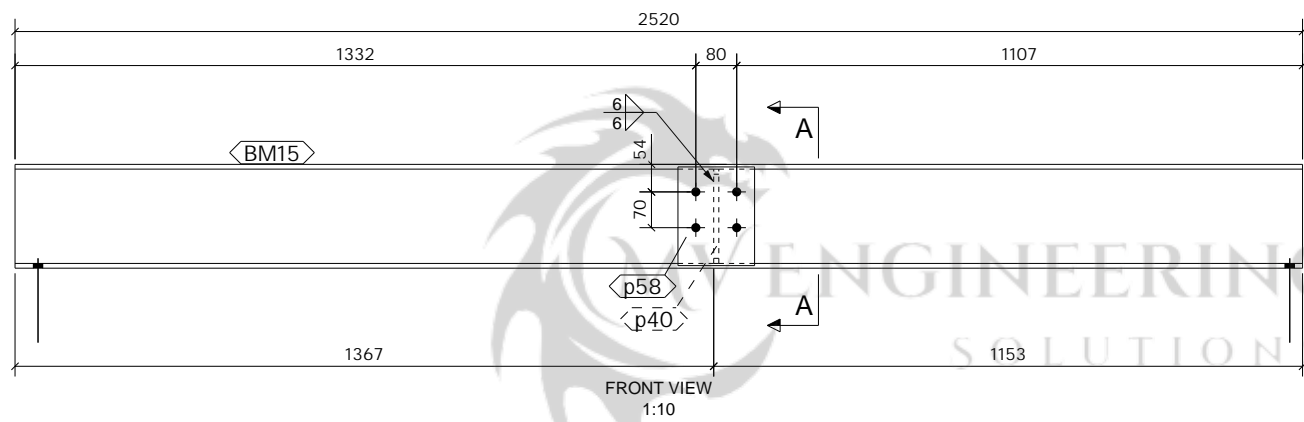
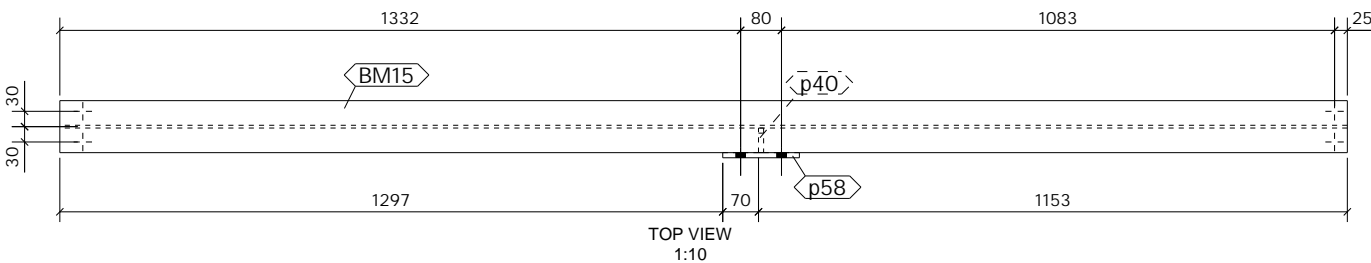

1 No. BEAM

REQUIRED AS DRAWN MARKED BM16

SHOP MATERIAL LIST FOR 1 ASSEMBLY

Mark	Size	Grade	No.	Length		Weight (kg)
				(mm)	(m) ²	
BM15	UB203*102*23	S275	1	2520	2.029	57.2
p40	PLT10*48.2	S275	1	185	0.022	0.7
p58	FLT10*150	S275	1	193	0.065	2.3
				Total	2.116	60.1

GENERAL NOTES

All Holes to be **22** Dia UNO Slot hole length is to outside
 All Welds to be **6** FW. UNO

All Steelwork Manufactured to:
 BS EN 1090-2: Execution Class **EXC2** U.N.O.

FINISH **S.B. & PRIME**
 LOT **0** QTY **1**
 PHASE **1** QTY **1**

FABRICATION STATUS

Sawn by: _____ Date: _____
 Fabricated by: _____ Date: _____
 Welded by: _____ Date: _____
 Loaded by: _____ Date: _____
 Checked by: _____ Date: _____

REV	DESCRIPTION	ISSUED FOR APPROVAL			
		By	Date	By	Date
A		PCS	25.01.2023	SK	25.01.2023
MARK		CREATED		CHECKED	

CLIENT: _____ **DATE CREATED:** 23.01.2023

PROJECT: Ebenezer Street **DRAWN BY:** PCS

CONTRACT NO: T8298 **DRAWING NO:** [BM.16] **REV:** A

ASSEMBLY / SUB ASSEMBLY STATUS	
1	THIS IS IT'S OWN ASSEMBLY

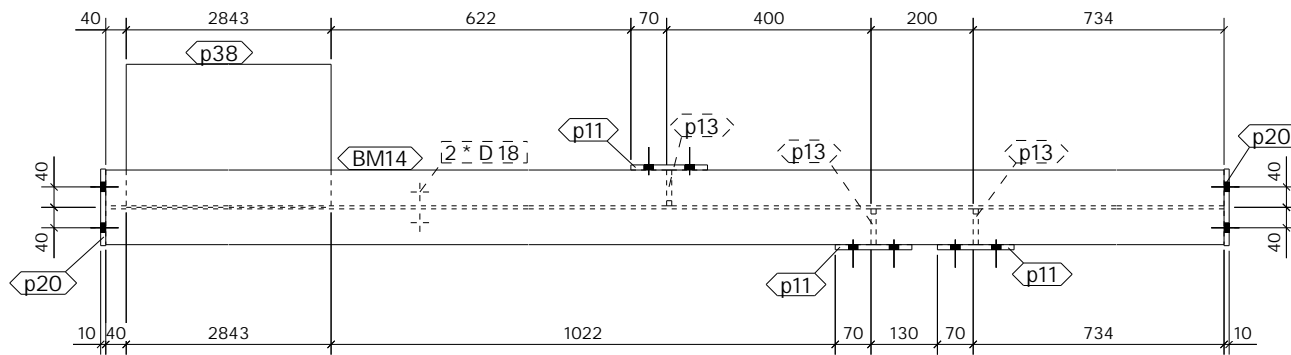

TOP VIEW
1:10

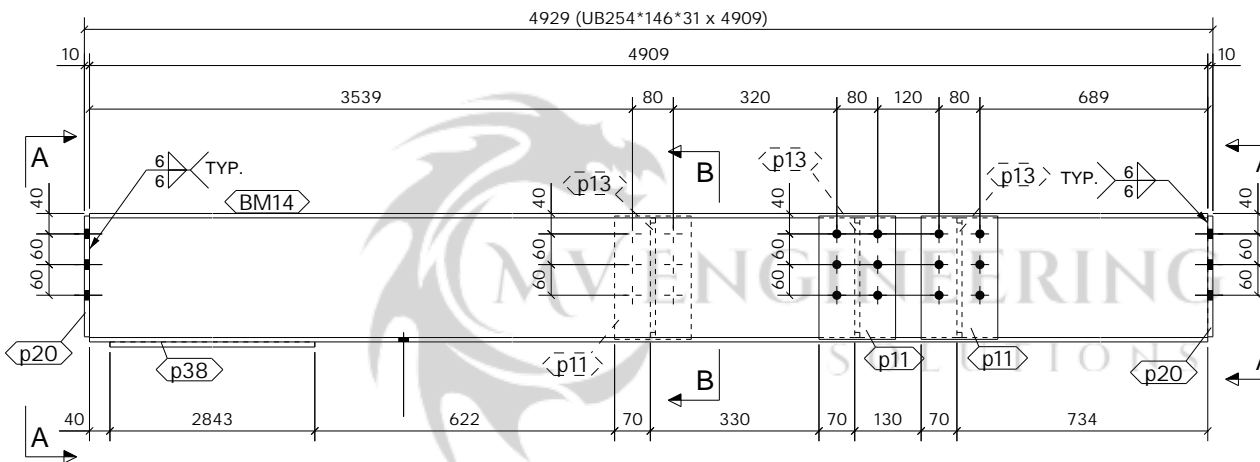

FRONT VIEW
1:10

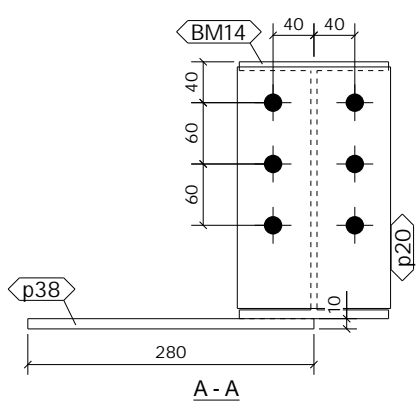

A - A

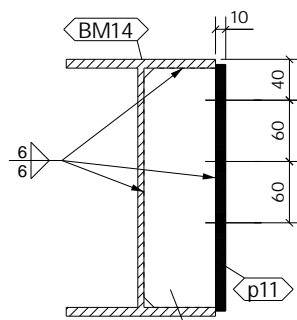

B - B

1 No. BEAM

REQUIRED AS DRAWN MARKED **BM17**

SHOP MATERIAL LIST FOR 1 ASSEMBLY

Mark	Size	Grade	No.	Length (mm)	Area (m ²)	Weight (kg)
BM14	UB254*146*31	S275	1	4909	5.286	151.0
p11	FLT10*150	S275	3	241	0.241	8.5
p13	FLT10*70	S275	3	234	0.116	3.8
p20	FLT10*150	S275	2	236	0.157	5.6
p38	PL10*280	S275	1	2843	1.654	62.5
Total					7.454	231.4

GENERAL NOTES

All Holes to be **22** Dia UNO Slot hole length is to outside
 All Welds to be **6** FW. UNO

All Steelwork Manufactured to:
 BS EN 1090-2: Execution Class **EXC2** U.N.O.

FINISH **S.B. & PRIME**
 LOT **0** QTY **1**
 PHASE **1** QTY **1**

FABRICATION STATUS

Sawn by: _____ Date: _____
 Fabricated by: _____ Date: _____
 Welded by: _____ Date: _____
 Loaded by: _____ Date: _____
 Checked by: _____ Date: _____

MARK	DESCRIPTION	CREATED		CHECKED	
		By	Date	By	Date
B	ISSUED FOR APPROVAL	PCS	01.02.2023	SK	01.02.2023
A	ISSUED FOR APPROVAL	PCS	25.01.2023	SK	25.01.2023

CLIENT: _____ **DATE CREATED:** 23.01.2023

PROJECT: Ebenezer Street **DRAWN BY:** PCS

CONTRACT NO: T8298 **DRAWING NO:** [BM.17] **REV:** B

ASSEMBLY / SUB ASSEMBLY STATUS	
1	THIS IS IT'S OWN ASSEMBLY

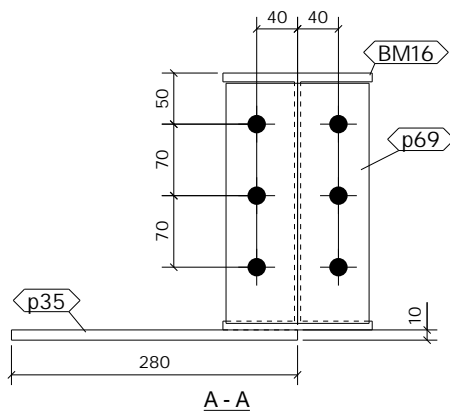
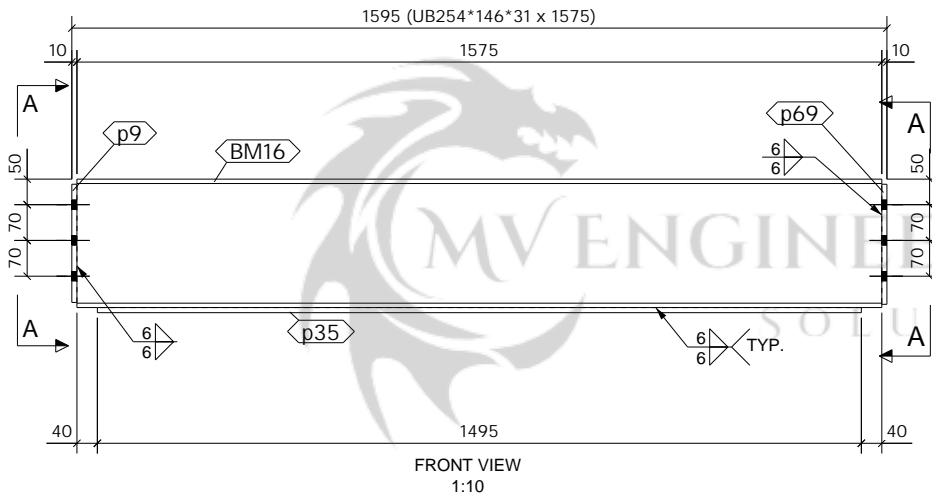
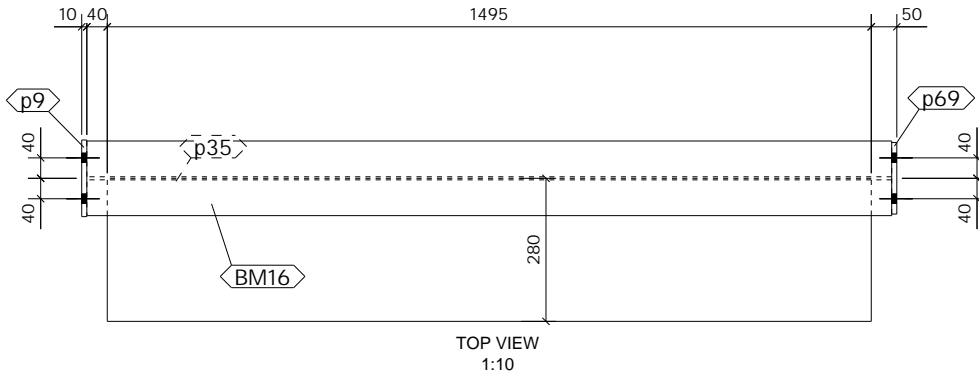

1 No. BEAM

REQUIRED AS DRAWN MARKED BM18

SHOP MATERIAL LIST FOR 1 ASSEMBLY

Mark	Size	Grade	No.	Length (mm)	Area (m ²)	Weight (kg)
BM16	UB254*146*31	S275	1	1575	1.702	48.5
p9	FLT10*150	S275	1	231	0.077	2.7
p35	PL10*280	S275	1	1495	0.873	32.9
p69	FLT10*140	S275	1	235	0.073	2.6
Total					2.725	86.6

GENERAL NOTES

All Holes to be 22 Dia UNO Slot hole length is to outside
 All Welds to be 6 FW. UNO

All Steelwork Manufactured to:
 BS EN 1090-2: Execution Class EXC2 U.N.O.

FINISH GALVANISED
 LOT 0 QTY 1
 PHASE 1 QTY 1

FABRICATION STATUS

Sawn by: _____ Date: _____
 Fabricated by: _____ Date: _____
 Welded by: _____ Date: _____
 Loaded by: _____ Date: _____
 Checked by: _____ Date: _____

REV	DESCRIPTION	By	Date	By	Date
B	ISSUED FOR APPROVAL	PCS	01.02.2023	SK	01.02.2023
A	ISSUED FOR APPROVAL	PCS	25.01.2023	SK	25.01.2023
MARK	DESCRIPTION	CREATED	CHECKED		

CLIENT: Ebenezzer Street DATE CREATED: 23.01.2023

PROJECT: Ebenezzer Street DRAWN BY: PCS

CONTRACT NO: T8298 DRAWING NO: [BM.18] REV: B

ASSEMBLY / SUB ASSEMBLY STATUS	
1	THIS IS IT'S OWN ASSEMBLY

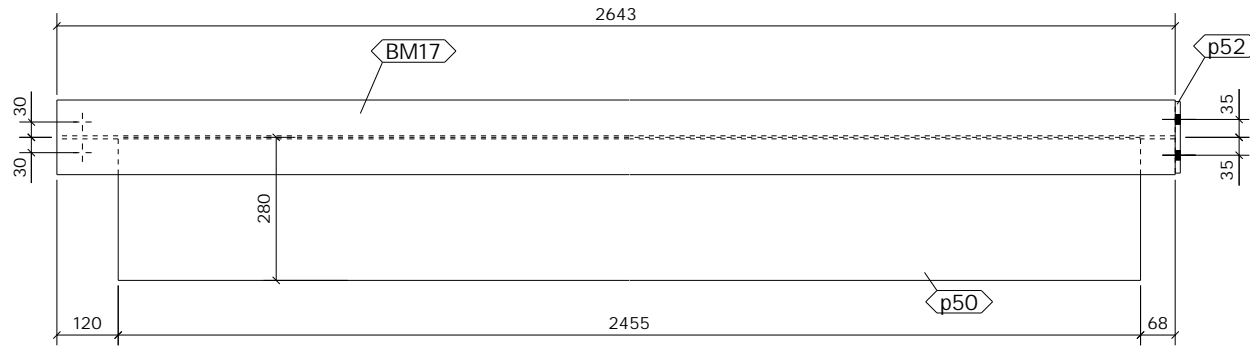

TOP VIEW
1:10

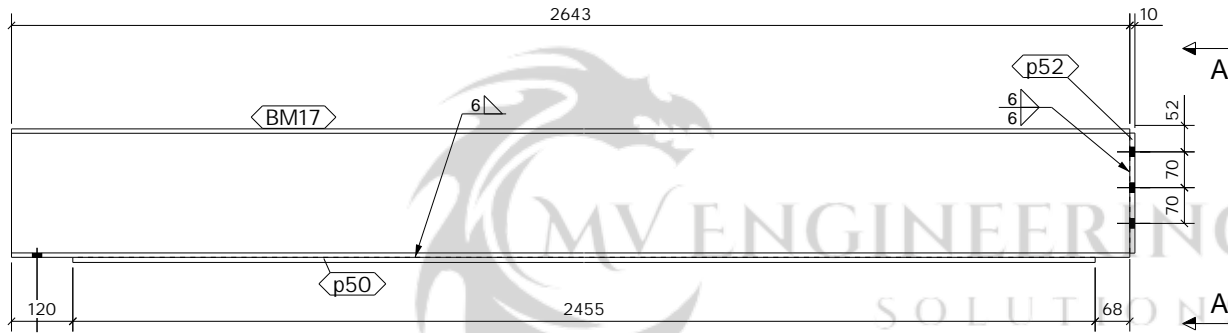

FRONT VIEW
1:10

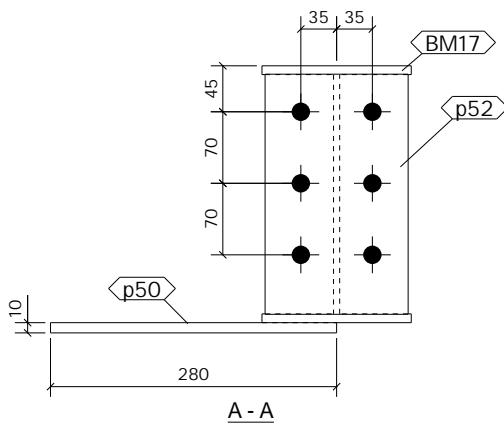

A - A

1 No. BEAM

REQUIRED AS DRAWN MARKED BM19

SHOP MATERIAL LIST FOR 1 ASSEMBLY

Mark	Size	Grade	No.	Length (mm)	Area (m ²)	Weight (kg)
BM17	UB254*146*31	S275	1	2643	2.849	81.3
p50	PL10*280	S275	1	2455	1.429	54.0
p52	FLT10*140	S275	1	235	0.073	2.6
Total					4.352	137.8

GENERAL NOTES

All Holes to be 22 Dia UNO Slot hole length is to outside
 All Welds to be 6 FW. UNO

All Steelwork Manufactured to:
 BS EN 1090-2: Execution Class **EXC2** U.N.O.

FINISH **GALVANISED**
 LOT **0** QTY **1**
 PHASE **1** QTY **1**

FABRICATION STATUS

Sawn by: _____ Date: _____
 Fabricated by: _____ Date: _____
 Welded by: _____ Date: _____
 Loaded by: _____ Date: _____
 Checked by: _____ Date: _____

B	ISSUED FOR APPROVAL	PCS	01.02.2023	SK	01.02.2023
A	ISSUED FOR APPROVAL	PCS	25.01.2023	SK	25.01.2023
REV		By	Date	By	Date
MARK	DESCRIPTION	CREATED	CHECKED		

CLIENT: _____ DATE CREATED: 23.01.2023

PROJECT: Ebenezer Street DRAWN BY: PCS

CONTRACT NO: T8298 DRAWING NO: [BM.19] REV: B

ASSEMBLY / SUB ASSEMBLY STATUS	
1	THIS IS IT'S OWN ASSEMBLY

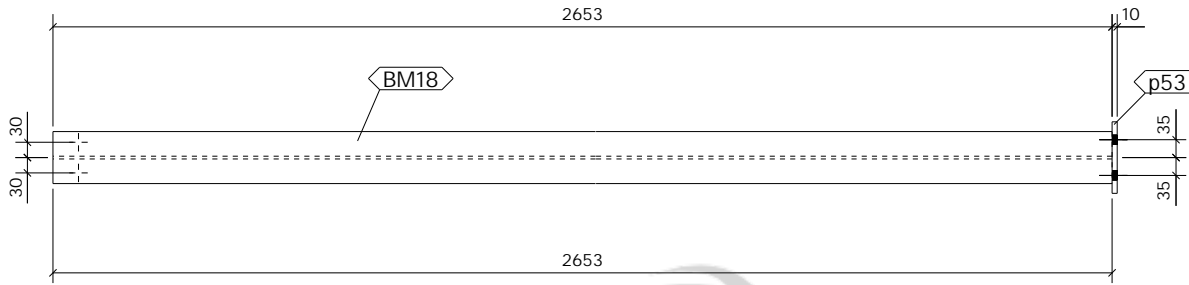

TOP VIEW
1:10

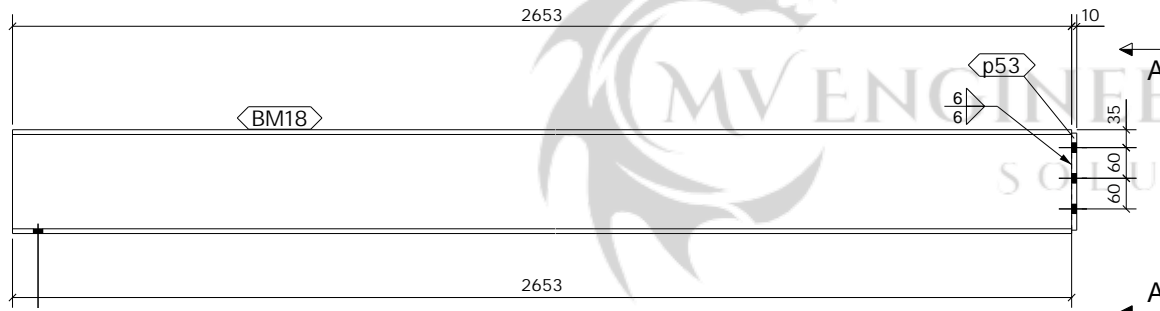

FRONT VIEW
1:10

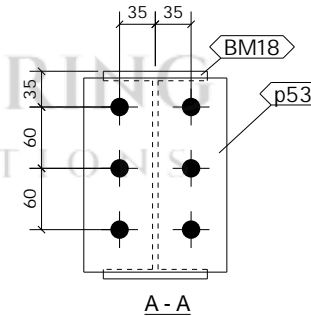

A - A

SHOP MATERIAL LIST FOR 1 ASSEMBLY

Mark	Size	Grade	No.	Length (mm)	Area (m ²)	Weight (kg)
BM18	UB203*102*23	S275	1	2653	2.135	60.2
p53	FLT10*140	S275	1	190	0.060	2.1
Total					2.195	62.3

GENERAL NOTES

All Holes to be **22** Dia UNO Slot hole length is to outside
 All Welds to be **6** FW. UNO

All Steelwork Manufactured to:
 BS EN 1090-2: Execution Class **EXC2** U.N.O.

FINISH **GALVANISED**
 LOT **0** QTY **1**
 PHASE **1** QTY **1**

FABRICATION STATUS

Sawn by: _____ Date: _____
 Fabricated by: _____ Date: _____
 Welded by: _____ Date: _____
 Loaded by: _____ Date: _____
 Checked by: _____ Date: _____

REV	DESCRIPTION	ISSUED FOR APPROVAL			
		By	Date	By	Date
A		PCS	25.01.2023	SK	25.01.2023
MARK		CREATED		CHECKED	

CLIENT: _____ **DATE CREATED:** 23.01.2023

PROJECT: Ebenezer Street **DRAWN BY:** PCS

CONTRACT NO: T8298 **DRAWING NO:** [BM.20] **REV:** A

1 No. BEAM

REQUIRED AS DRAWN MARKED BM20

ASSEMBLY / SUB ASSEMBLY STATUS	
1	THIS IS IT'S OWN ASSEMBLY

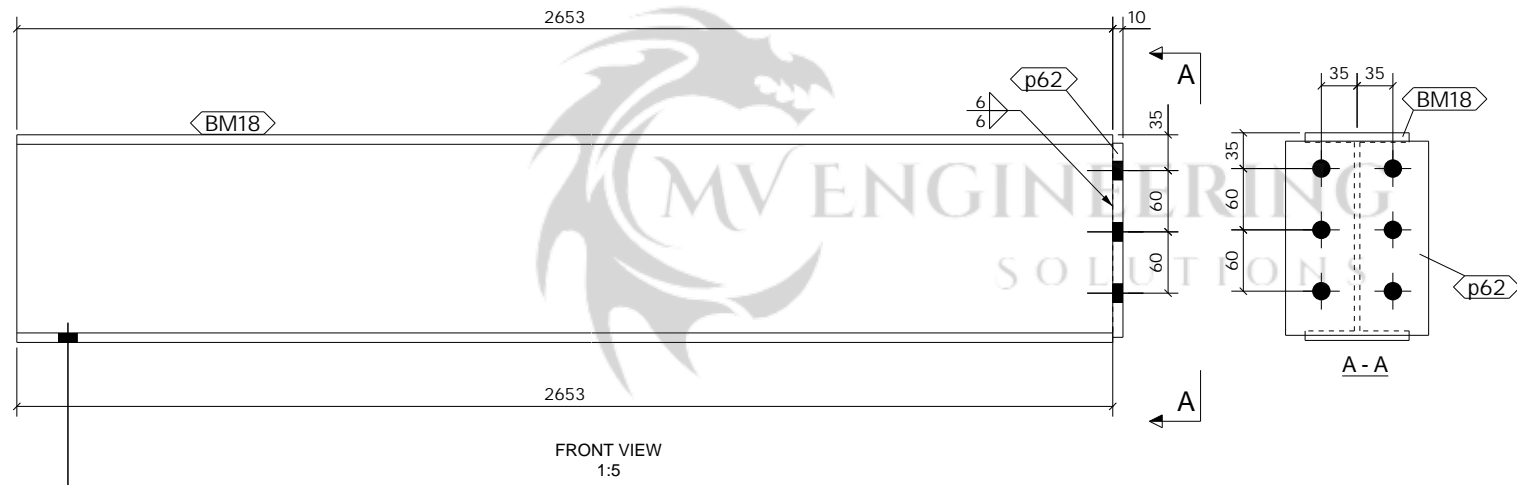
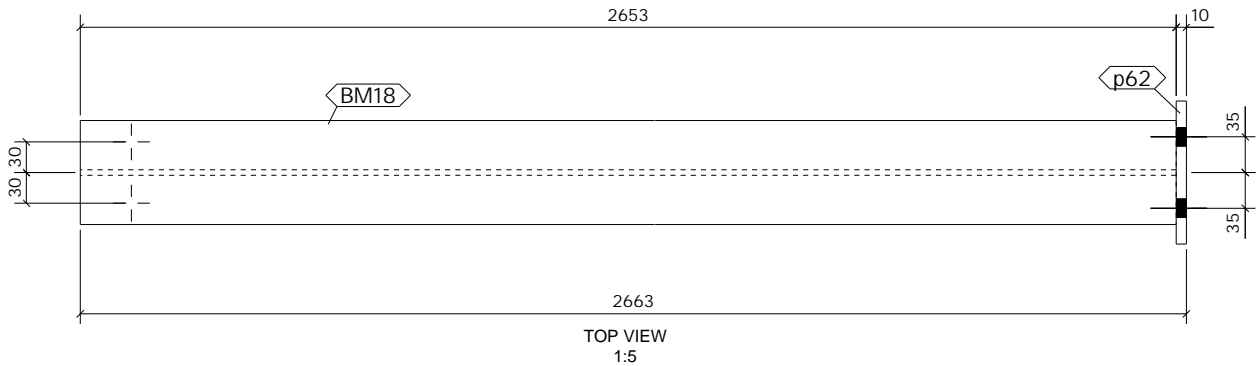

SHOP MATERIAL LIST FOR 1 ASSEMBLY

Mark	Size	Grade	No.	Length (mm)	Area (m ²)	Weight (kg)
BM18	UB203*102*23	S275	1	2653	2.135	60.2
p62	FLT10*140	S275	1	190	0.060	2.1
Total					2.195	62.3

GENERAL NOTES

All Holes to be **22** Dia UNO Slot hole length is to outside
 All Welds to be **6** FW. UNO

All Steelwork Manufactured to:
 BS EN 1090-2: Execution Class **EXC2** U.N.O.

FINISH **GALVANISED**
 LOT **0** QTY **1**
 PHASE **1** QTY **1**

FABRICATION STATUS

Sawn by: _____ Date: _____
 Fabricated by: _____ Date: _____
 Welded by: _____ Date: _____
 Loaded by: _____ Date: _____
 Checked by: _____ Date: _____

REV	DESCRIPTION	ISSUED FOR APPROVAL			
		By	Date	By	Date
A		PCS	25.01.2023	SK	25.01.2023
MARK		CREATED		CHECKED	

CLIENT: _____ **DATE CREATED:** 23.01.2023

PROJECT: Ebenezer Street **DRAWN BY:** PCS

CONTRACT NO: T8298 **DRAWING NO:** [BM.21] **REV:** A

1 No. BEAM

REQUIRED AS DRAWN MARKED BM21

ASSEMBLY / SUB ASSEMBLY STATUS	
1	THIS IS IT'S OWN ASSEMBLY

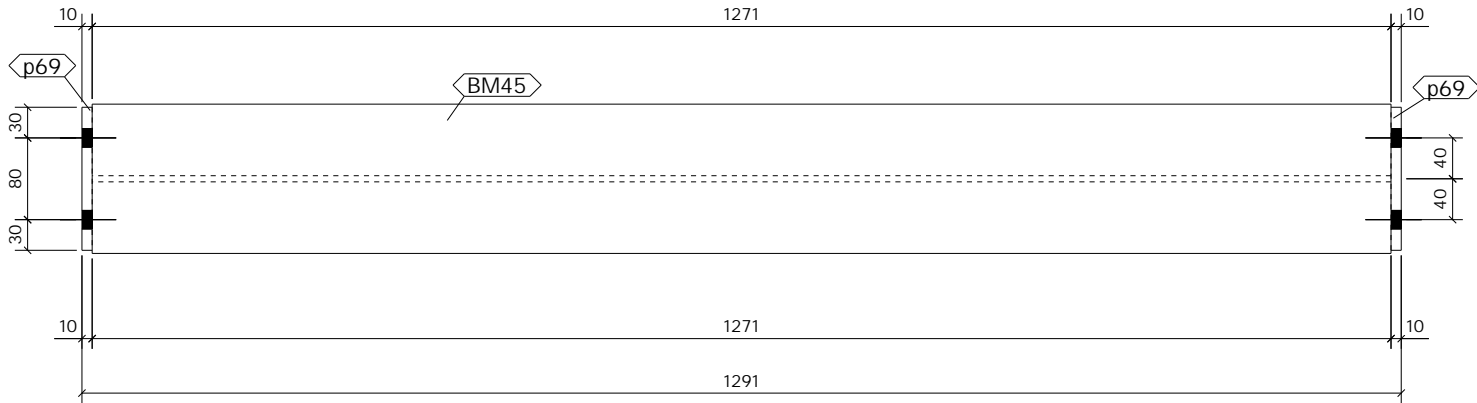

TOP VIEW
1:5

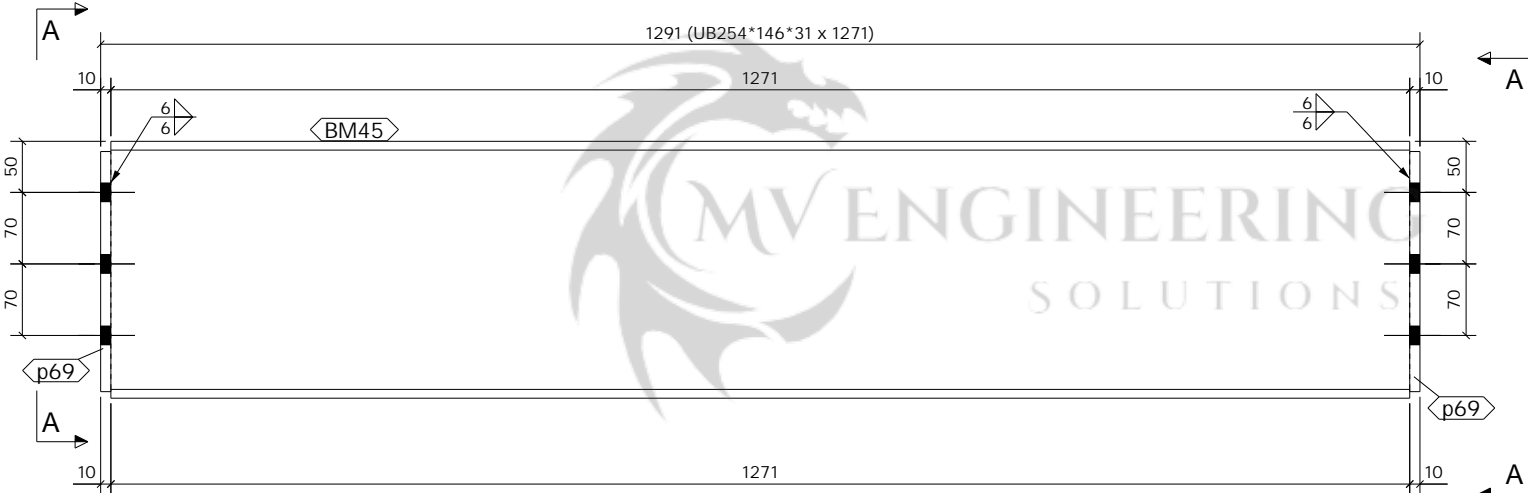

FRONT VIEW
1:5

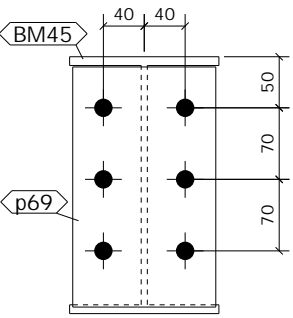

A - A

1 No. BEAM

REQUIRED AS DRAWN MARKED BM22

SHOP MATERIAL LIST FOR 1 ASSEMBLY						
Mark	Size	Grade	No.	Length (mm)	Area (m ²)	Weight (kg)
BM45	UB254*146*31	S275	1	1271	1.375	39.1
p69	FLT10*140	S275	2	235	0.147	5.2
Total					1.521	44.3

GENERAL NOTES

All Holes to be **22** Dia UNO Slot hole length is to outside
 All Welds to be **6** FW. UNO

All Steelwork Manufactured to:
 BS EN 1090-2: Execution Class **EXC2** U.N.O.

FINISH **GALVANISED**

LOT **0** QTY **1**
 PHASE **1** QTY **1**

FABRICATION STATUS	
Sawn by: _____	Date: _____
Fabricated by: _____	Date: _____
Welded by: _____	Date: _____
Loaded by: _____	Date: _____
Checked by: _____	Date: _____

A	ISSUED FOR APPROVAL			
	PCS	25.01.2023	SK	25.01.2023
REV	By	Date	By	Date
MARK	DESCRIPTION	CREATED	CHECKED	

CLIENT:	DATE CREATED:	
Ebenezer Street	23.01.2023	
PROJECT:	DRAWN BY:	
Ebenezer Street	PCS	
CONTRACT NO:	DRAWING NO:	REV:
T8298	[BM.22]	A

ASSEMBLY / SUB ASSEMBLY STATUS	
1	THIS IS IT'S OWN ASSEMBLY

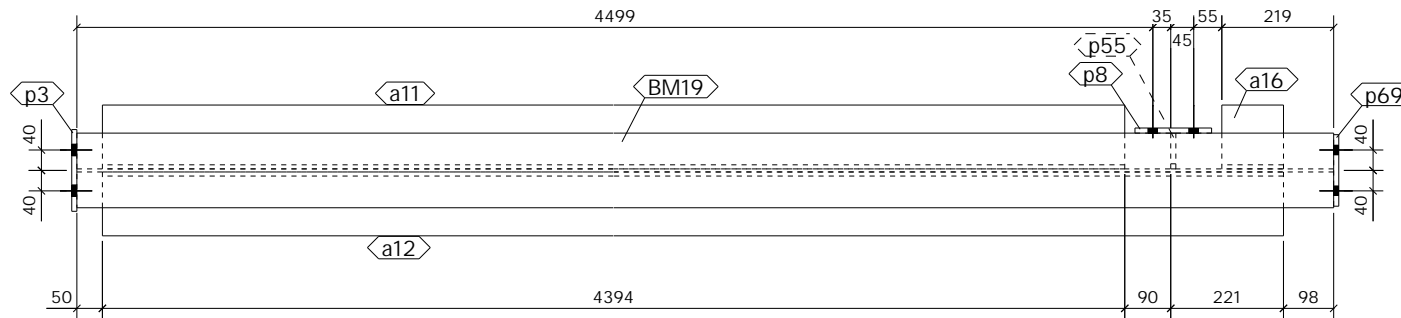

TOP VIEW
1:10

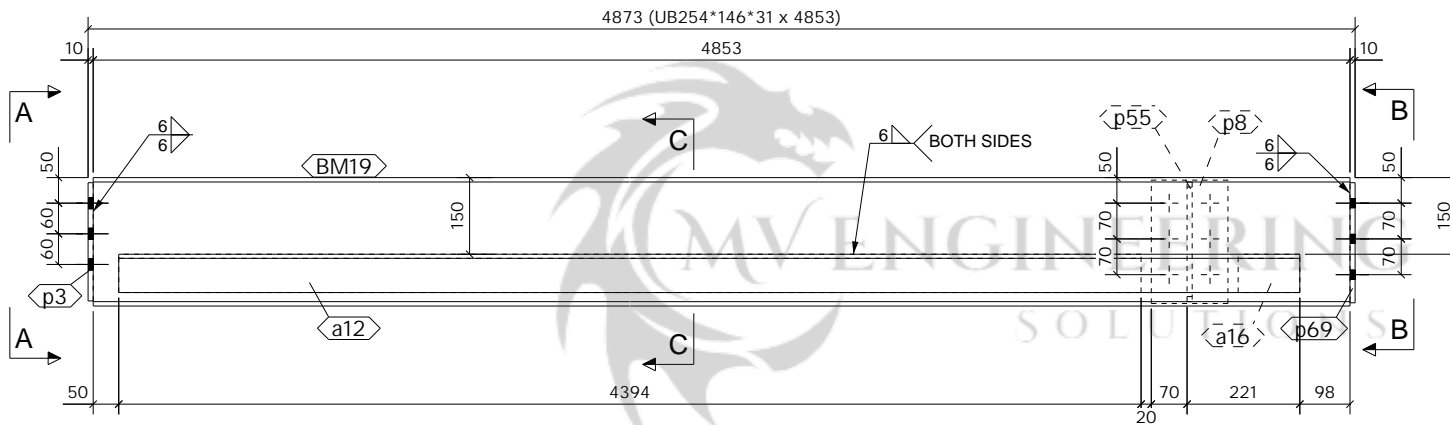

FRONT VIEW
1:10

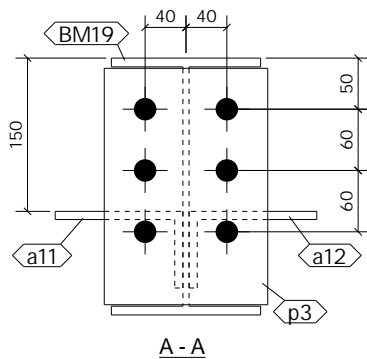

A - A

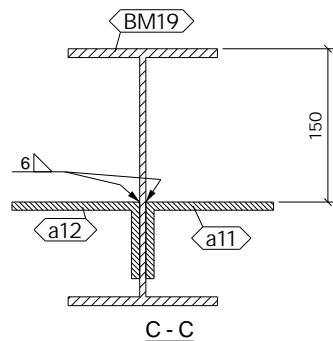

C - C

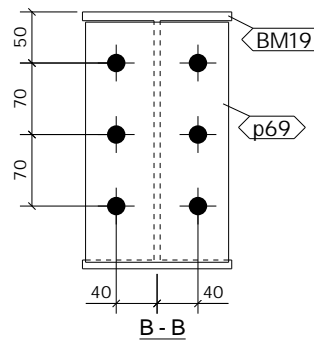

B - B

1 No. BEAM

REQUIRED AS DRAWN MARKED BM23

SHOP MATERIAL LIST FOR 1 ASSEMBLY

Mark	Size	Grade	No.	Length (mm)	Area (m ²)	Weight (kg)
BM19	UB254*146*31	S275	1	4853	5.226	149.3
a11	RSA125*75*8	S275	1	4394	1.761	53.0
a12	RSA125*75*8	S275	1	4705	1.885	56.7
a16	RSA125*75*8	S275	1	121	0.051	1.5
p3	PLT10*160	S275	1	231	0.082	2.9
p8	FLT10*150	S275	1	241	0.080	2.8
p55	FLT10*70	S275	1	234	0.039	1.3
p69	FLT10*140	S275	1	235	0.073	2.6
				Total	9.197	270.0

GENERAL NOTES

All Holes to be 22 Dia UNO Slot hole length is to outside
All Welds to be 6 FW. UNO

All Steelwork Manufactured to:
BS EN 1090-2: Execution Class EXC2 U.N.O.

FINISH GALVANISED
LOT 0 QTY 1
PHASE 1 QTY 1

FABRICATION STATUS

Sawn by: _____ Date: _____
Fabricated by: _____ Date: _____
Welded by: _____ Date: _____
Loaded by: _____ Date: _____
Checked by: _____ Date: _____

REV	DESCRIPTION	ISSUED FOR APPROVAL			
		By	Date	By	Date
A		PCS	25.01.2023	SK	25.01.2023
MARK		CREATED		CHECKED	

CLIENT: _____ DATE CREATED: 23.01.2023

PROJECT: Ebenezer Street DRAWN BY: PCS

CONTRACT NO: T8298 DRAWING NO: [BM.23] REV: A

ASSEMBLY / SUB ASSEMBLY STATUS	
1	THIS IS IT'S OWN ASSEMBLY

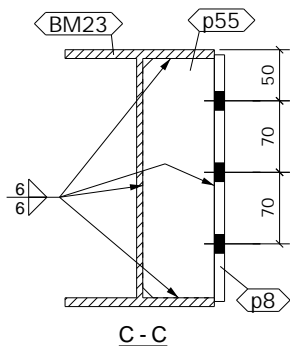
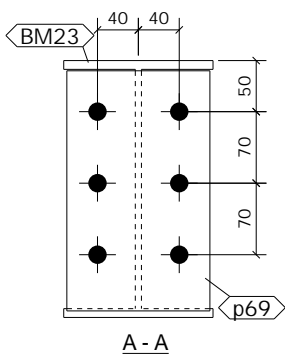
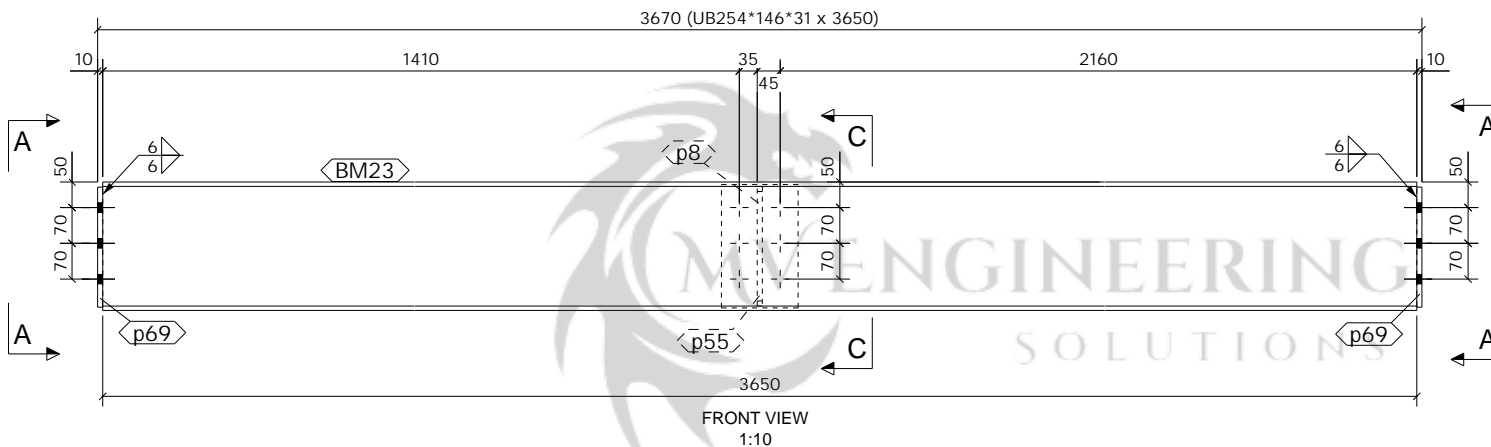
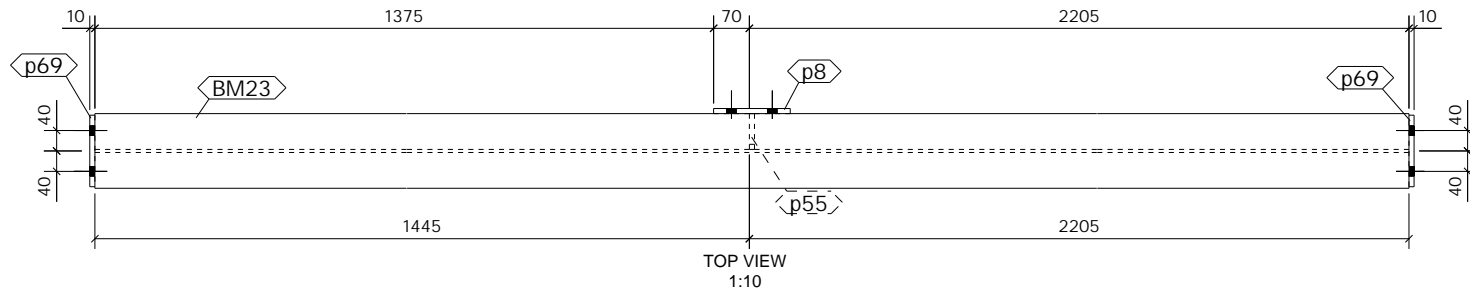

1 No. BEAM

REQUIRED AS DRAWN MARKED BM24

SHOP MATERIAL LIST FOR 1 ASSEMBLY

Mark	Size	Grade	No.	Length (mm)	Area (m ²)	Weight (kg)
BM23	UB254*146*31	S275	1	3650	3.933	112.3
p8	FLT10*150	S275	1	241	0.080	2.8
p55	FLT10*70	S275	1	234	0.039	1.3
p69	FLT10*140	S275	2	235	0.147	5.2
Total					4.198	121.6

GENERAL NOTES

All Holes to be **22** Dia UNO Slot hole length is to outside
 All Welds to be **6** FW. UNO

All Steelwork Manufactured to:
 BS EN 1090-2: Execution Class **EXC2** U.N.O.

FINISH **GALVANISED**
 LOT **0** QTY **1**
 PHASE **1** QTY **1**

FABRICATION STATUS

Sawn by: _____ Date: _____
 Fabricated by: _____ Date: _____
 Welded by: _____ Date: _____
 Loaded by: _____ Date: _____
 Checked by: _____ Date: _____

REV	DESCRIPTION	ISSUED FOR APPROVAL			
		By	Date	By	Date
A		PCS	25.01.2023	SK	25.01.2023
MARK		CREATED		CHECKED	

CLIENT: Ebenezzer Street
DATE CREATED: 23.01.2023

PROJECT: Ebenezzer Street
DRAWN BY: PCS

CONTRACT NO: T8298
DRAWING NO: [BM.24]
REV: A

ASSEMBLY / SUB ASSEMBLY STATUS	
1	THIS IS IT'S OWN ASSEMBLY

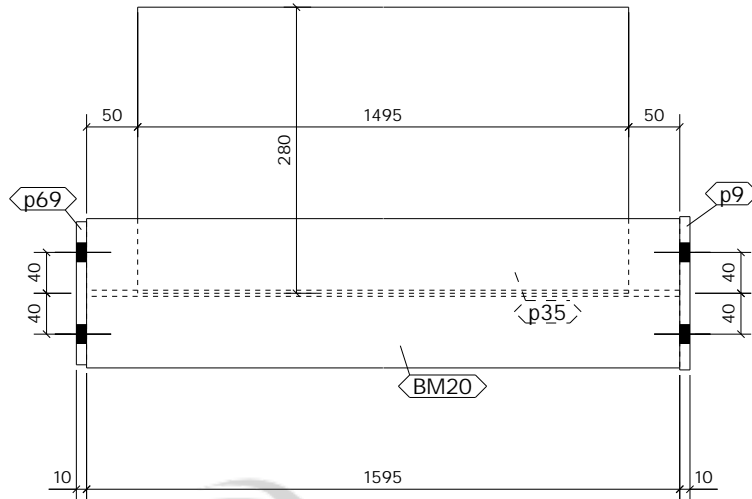

TOP VIEW
1:5

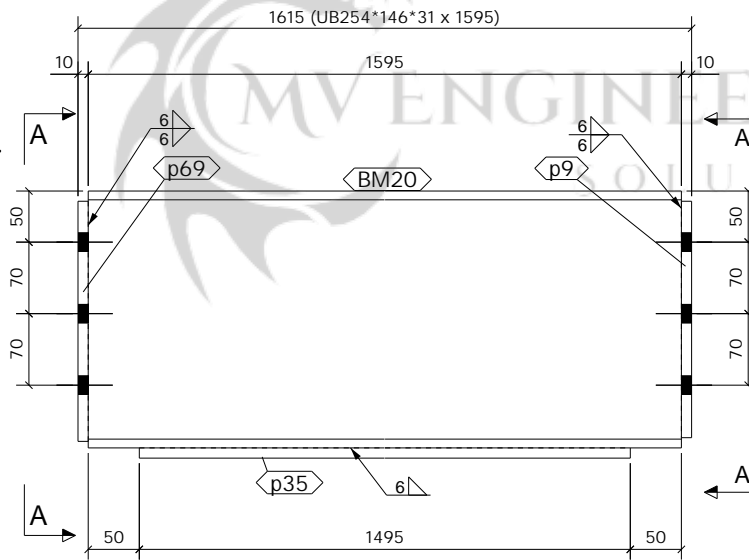

FRONT VIEW
1:5

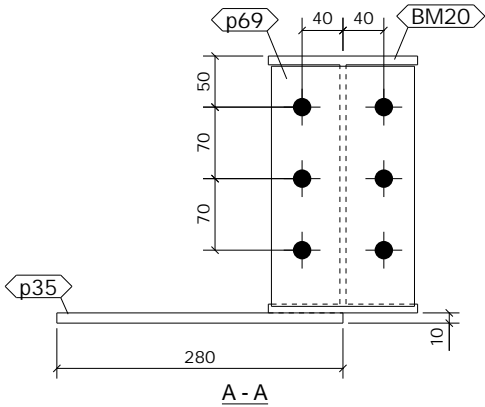

A - A

SHOP MATERIAL LIST FOR 1 ASSEMBLY

Mark	Size	Grade	No.	Length (mm)	Area (m ²)	Weight (kg)
BM20	UB254*146*31	S275	1	1595	1.723	49.1
p9	FLT10*150	S275	1	231	0.077	2.7
p35	PL10*280	S275	1	1495	0.873	32.9
p69	FLT10*140	S275	1	235	0.073	2.6
Total					2.746	87.2

GENERAL NOTES

All Holes to be **22** Dia UNO Slot hole length is to outside
 All Welds to be **6** FW. UNO

All Steelwork Manufactured to:
 BS EN 1090-2: Execution Class **EXC2** U.N.O.

FINISH **GALVANISED**
 LOT **0** QTY **1**
 PHASE **1** QTY **1**

FABRICATION STATUS

Sawn by: _____ Date: _____
 Fabricated by: _____ Date: _____
 Welded by: _____ Date: _____
 Loaded by: _____ Date: _____
 Checked by: _____ Date: _____

B	ISSUED FOR APPROVAL	PCS	01.02.2023	SK	01.02.2023
A	ISSUED FOR APPROVAL	PCS	25.01.2023	SK	25.01.2023
REV		By	Date	By	Date
MARK	DESCRIPTION	CREATED	CHECKED		

CLIENT: _____ **DATE CREATED:** 23.01.2023

PROJECT: Ebenezer Street **DRAWN BY:** PCS

CONTRACT NO: T8298 **DRAWING NO:** [BM.25] **REV:** B

1 No. BEAM

REQUIRED AS DRAWN MARKED **BM25**

ASSEMBLY / SUB ASSEMBLY STATUS	
1	THIS IS IT'S OWN ASSEMBLY

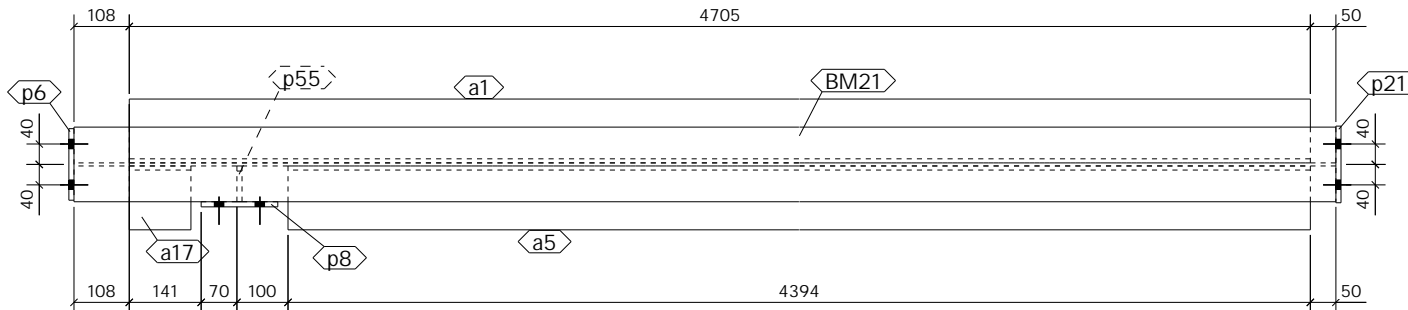

TOP VIEW
1:10

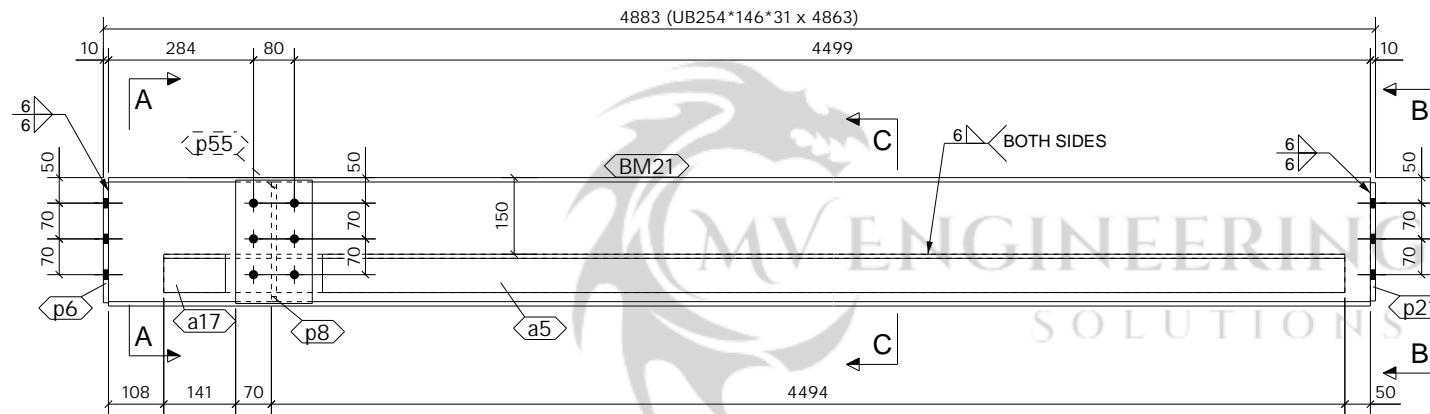

FRONT VIEW
1:10

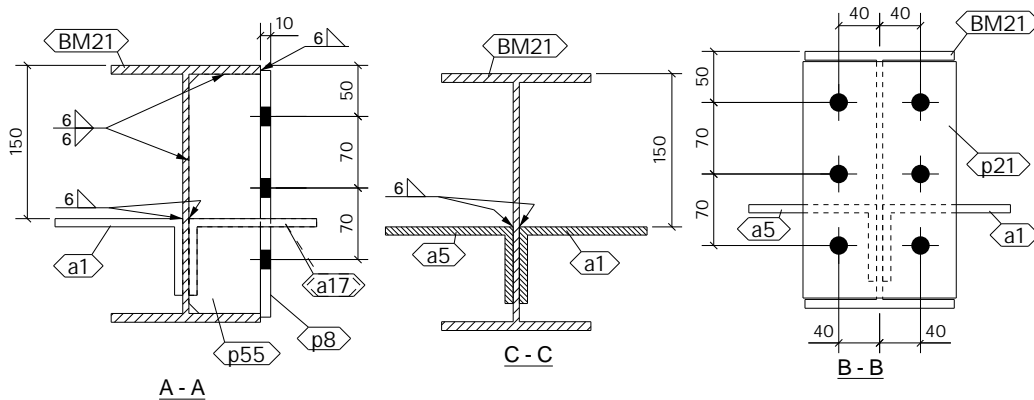

1 No. BEAM

REQUIRED AS DRAWN MARKED BM26

SHOP MATERIAL LIST FOR 1 ASSEMBLY

Mark	Size	Grade	No.	Length (mm)	Area (m ²)	Weight (kg)
BM21	UB254*146*31	S275	1	4863	5.237	149.6
a1	RSA125*75*8	S275	1	4705	1.885	56.7
a5	RSA125*75*8	S275	1	4394	1.761	53.0
a17	RSA125*75*8	S275	1	121	0.051	1.5
p6	FLT10*140	S275	1	235	0.073	2.6
p8	FLT10*150	S275	1	241	0.080	2.8
p21	FLT10*150	S275	1	231	0.077	2.7
p55	FLT10*70	S275	1	234	0.039	1.3
				Total	9.203	270.2

GENERAL NOTES

All Holes to be **22** Dia UNO Slot hole length is to outside
All Welds to be **6** FW. UNO

All Steelwork Manufactured to:
BS EN 1090-2: Execution Class **EXC2** U.N.O.

FINISH **S.B. & PRIME**
LOT **0** QTY **1**
PHASE **1** QTY **1**

FABRICATION STATUS

Sawn by: _____ Date: _____
Fabricated by: _____ Date: _____
Welded by: _____ Date: _____
Loaded by: _____ Date: _____
Checked by: _____ Date: _____

REV	DESCRIPTION	ISSUED FOR APPROVAL			
		By	Date	By	Date
A		PCS	25.01.2023	SK	25.01.2023
MARK		CREATED		CHECKED	

CLIENT: _____ DATE CREATED: 23.01.2023

PROJECT: Ebenezer Street DRAWN BY: PCS

CONTRACT NO: T8298 DRAWING NO: [BM.26] REV: A

ASSEMBLY / SUB ASSEMBLY STATUS	
1	THIS IS IT'S OWN ASSEMBLY

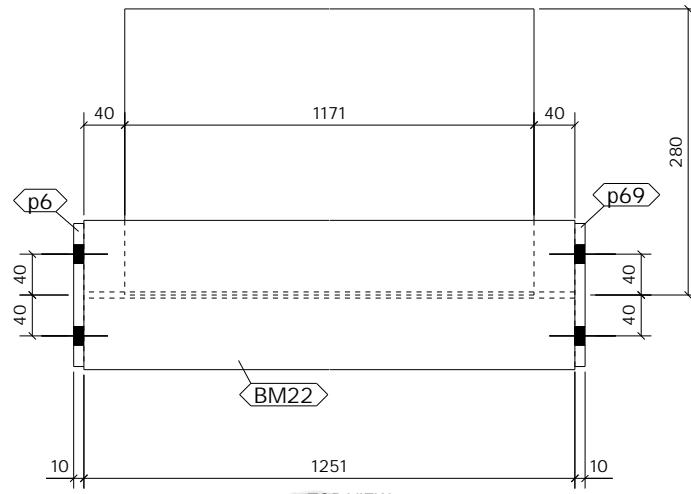

TOP VIEW
1:5

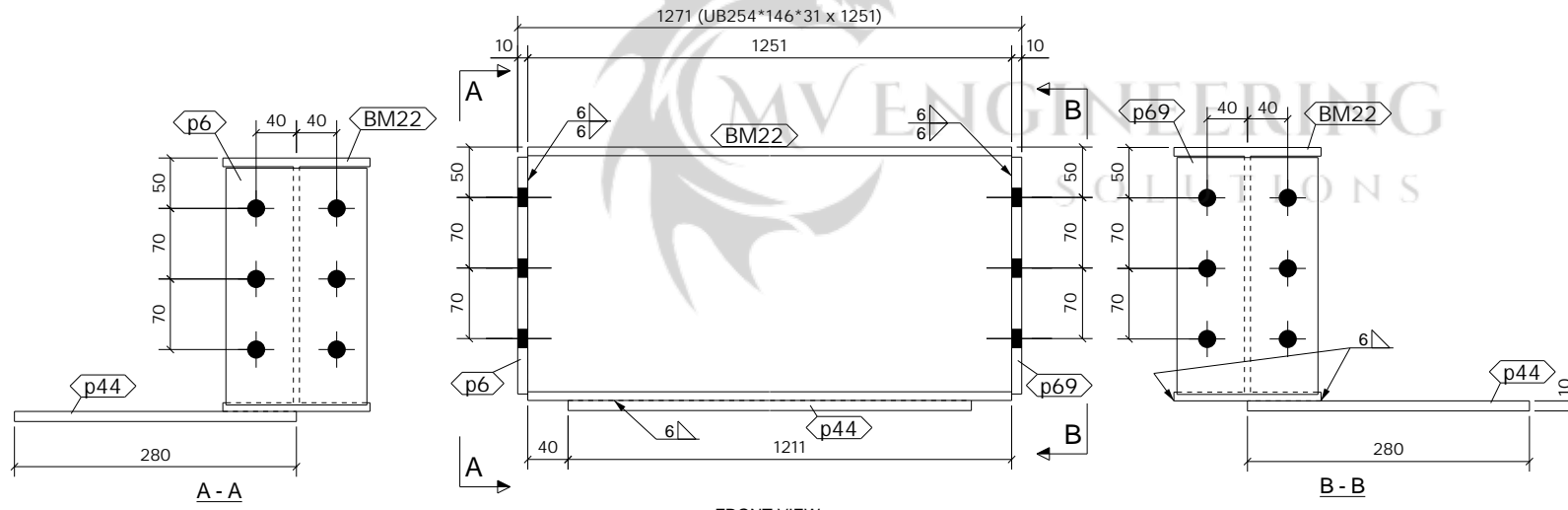

FRONT VIEW
1:5

1 No. BEAM

REQUIRED AS DRAWN MARKED BM27

SHOP MATERIAL LIST FOR 1 ASSEMBLY

Mark	Size	Grade	No.	Length (mm)	Area (m ²)	Weight (kg)
BM22	UB254*146*31	S275	1	1251	1.353	38.5
p6	FLT10*140	S275	1	235	0.073	2.6
p44	PL10*280	S275	1	1171	0.685	25.7
p69	FLT10*140	S275	1	235	0.073	2.6
Total					2.184	69.4

GENERAL NOTES

All Holes to be 22 Dia UNO Slot hole length is to outside
All Welds to be 6 FW. UNO

All Steelwork Manufactured to:
BS EN 1090-2: Execution Class EXC2 U.N.O.

FINISH GALVANISED
LOT 0 QTY 1
PHASE 1 QTY 1

FABRICATION STATUS

Sawn by: _____ Date: _____
Fabricated by: _____ Date: _____
Welded by: _____ Date: _____
Loaded by: _____ Date: _____
Checked by: _____ Date: _____

REV	DESCRIPTION	By	Date	By	Date
B	ISSUED FOR APPROVAL	PCS	01.02.2023	SK	01.02.2023
A	ISSUED FOR APPROVAL	PCS	25.01.2023	SK	25.01.2023
MARK	DESCRIPTION	CREATED	CHECKED		

CLIENT: Ebenezzer Street DATE CREATED: 23.01.2023

PROJECT: Ebenezzer Street DRAWN BY: PCS

CONTRACT NO: T8298 DRAWING NO: [BM.27] REV: B

ASSEMBLY / SUB ASSEMBLY STATUS	
1	THIS IS IT'S OWN ASSEMBLY

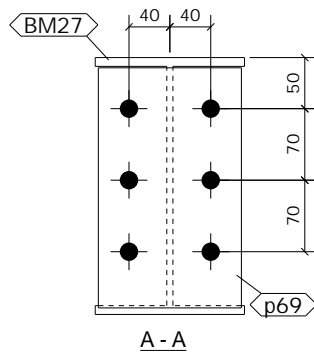
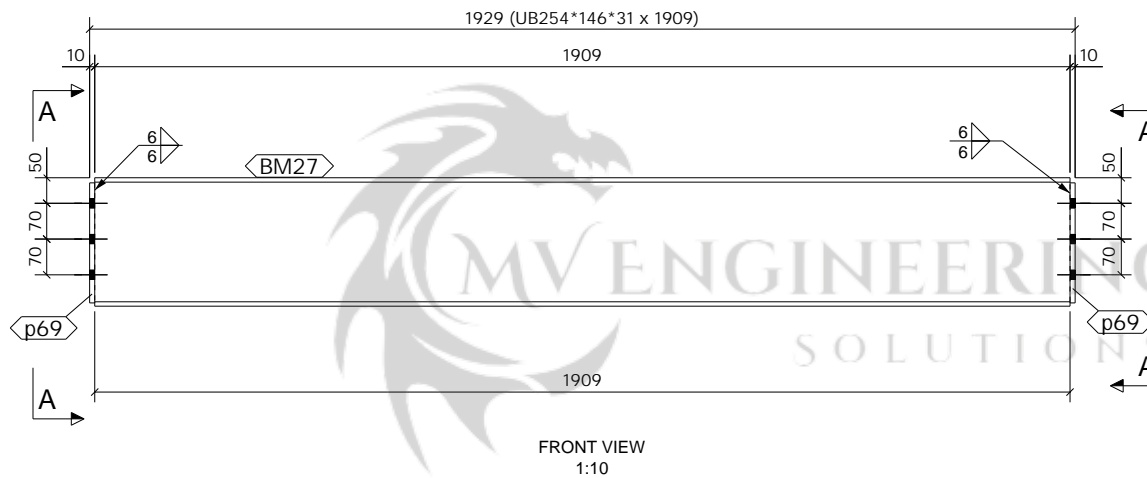
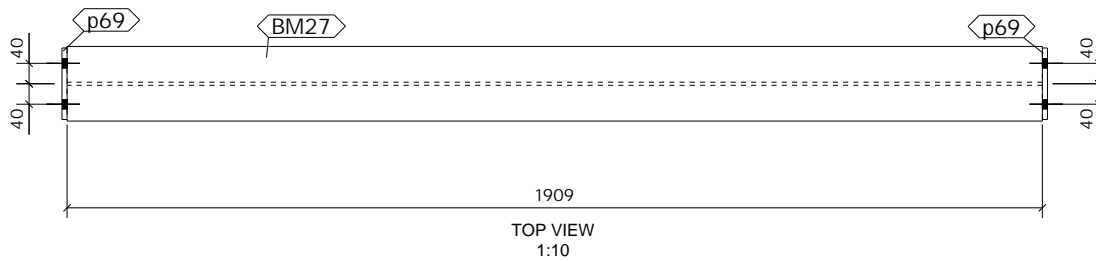

1 No. BEAM

REQUIRED AS DRAWN MARKED BM28

SHOP MATERIAL LIST FOR 1 ASSEMBLY

Mark	Size	Grade	No.	Length (mm)	Area (m ²)	Weight (kg)
BM27	UB254*146*31	S275	1	1909	2.060	58.7
p69	FLT10*140	S275	2	235	0.147	5.2
Total					2.207	63.9

GENERAL NOTES

All Holes to be 22 Dia UNO Slot hole length is to outside
 All Welds to be 6 FW. UNO

All Steelwork Manufactured to:
 BS EN 1090-2: Execution Class **EXC2** U.N.O.

FINISH **GALVANISED**
 LOT **0** QTY **1**
 PHASE **1** QTY **1**

FABRICATION STATUS

Sawn by: _____ Date: _____
 Fabricated by: _____ Date: _____
 Welded by: _____ Date: _____
 Loaded by: _____ Date: _____
 Checked by: _____ Date: _____

REV	DESCRIPTION	ISSUED FOR APPROVAL			
		By	Date	By	Date
A		PCS	25.01.2023	SK	25.01.2023
MARK		CREATED		CHECKED	

CLIENT: _____ DATE CREATED: 23.01.2023

PROJECT: Ebenezer Street DRAWN BY: PCS

CONTRACT NO: T8298 DRAWING NO: [BM.28] REV: A

ASSEMBLY / SUB ASSEMBLY STATUS	
1	THIS IS IT'S OWN ASSEMBLY

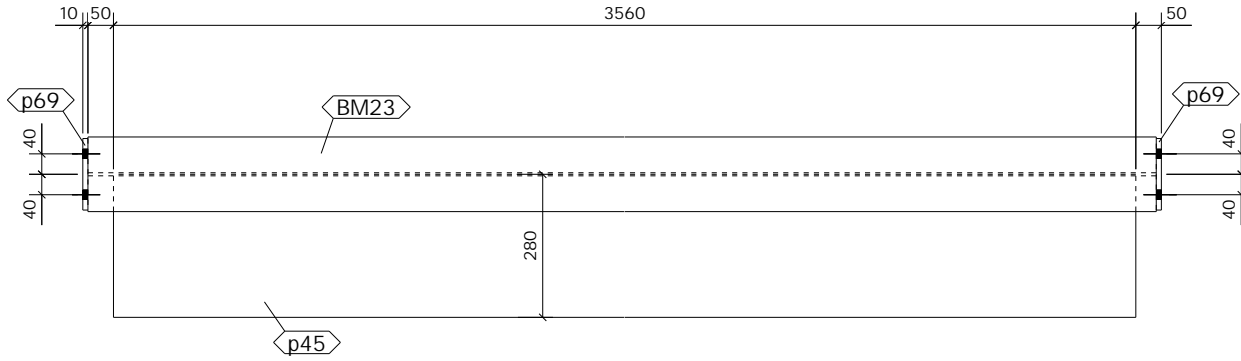

TOP VIEW
1:10

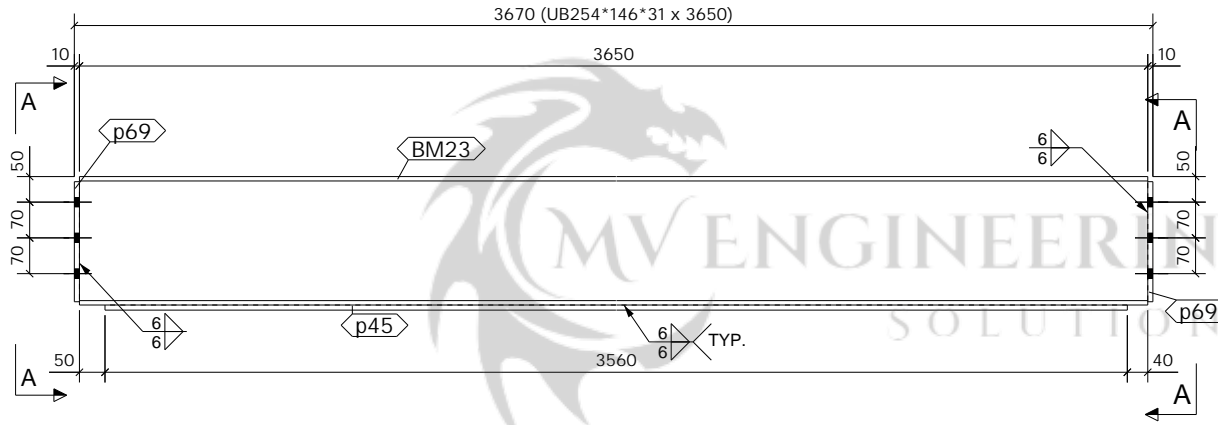

FRONT VIEW
1:10

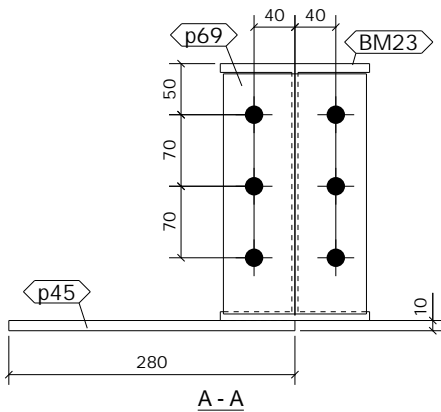

1 No. BEAM

REQUIRED AS DRAWN MARKED BM29

SHOP MATERIAL LIST FOR 1 ASSEMBLY

Mark	Size	Grade	No.	Length (mm)	Area (m ²)	Weight (kg)
BM23	UB254*146*31	S275	1	3650	3.933	112.3
p45	PL10*280	S275	1	3560	2.071	78.3
p69	FLT10*140	S275	2	235	0.147	5.2
Total					6.150	195.7

GENERAL NOTES

All Holes to be 22 Dia UNO Slot hole length is to outside
All Welds to be 6 FW. UNO

All Steelwork Manufactured to:
BS EN 1090-2: Execution Class **EXC2** U.N.O.

FINISH **GALVANISED**

LOT **0** QTY **1**

PHASE **1** QTY **1**

FABRICATION STATUS

Sawn by: _____ Date: _____
Fabricated by: _____ Date: _____
Welded by: _____ Date: _____
Loaded by: _____ Date: _____
Checked by: _____ Date: _____

B	ISSUED FOR APPROVAL	PCS	01.02.2023	SK	01.02.2023
A	ISSUED FOR APPROVAL	PCS	25.01.2023	SK	25.01.2023
REV		By	Date	By	Date
MARK	DESCRIPTION	CREATED	CHECKED		

CLIENT: _____ DATE CREATED: 23.01.2023

PROJECT: Ebenezer Street DRAWN BY: PCS

CONTRACT NO: T8298 DRAWING NO: [BM.29] REV: B

ASSEMBLY / SUB ASSEMBLY STATUS	
1	THIS IS IT'S OWN ASSEMBLY

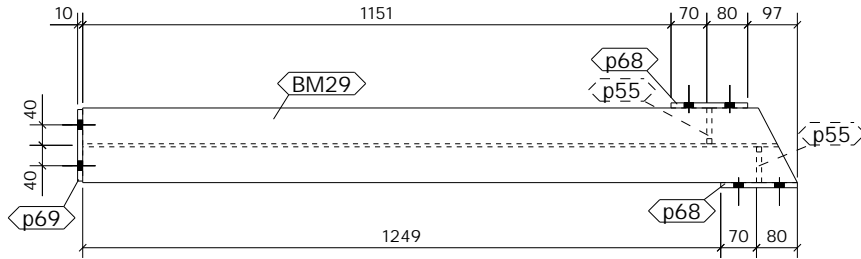

TOP VIEW
1:10

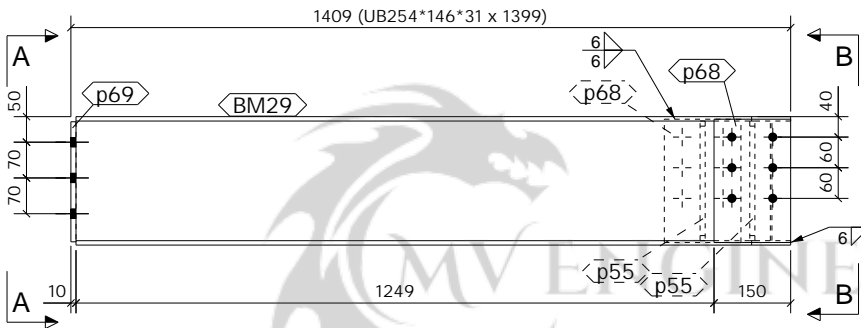

FRONT VIEW
1:10

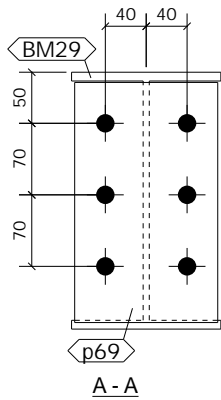

A - A

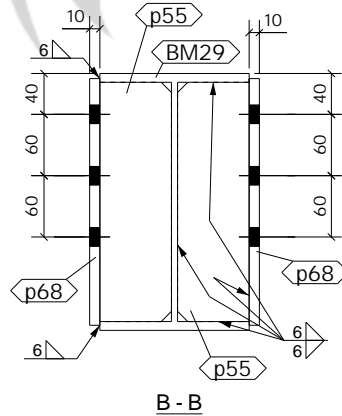

B - B

1 No. BEAM

REQUIRED AS DRAWN MARKED BM30

SHOP MATERIAL LIST FOR 1 ASSEMBLY

Mark	Size	Grade	No.	Length (mm)	Area (m ²)	Weight (kg)
BM29	UB254*146*31	S275	1	1399	1.471	41.8
p55	FLT10*70	S275	2	234	0.077	2.6
p68	FLT10*150	S275	2	241	0.160	5.7
p69	FLT10*140	S275	1	235	0.073	2.6
Total					1.782	52.7

GENERAL NOTES

All Holes to be 22 Dia UNO Slot hole length is to outside
All Welds to be 6 FW. UNO

All Steelwork Manufactured to:
BS EN 1090-2: Execution Class EXC2 U.N.O.

FINISH GALVANISED
LOT 0 QTY 1
PHASE 1 QTY 1

FABRICATION STATUS

Sawn by: _____ Date: _____
Fabricated by: _____ Date: _____
Welded by: _____ Date: _____
Loaded by: _____ Date: _____
Checked by: _____ Date: _____

REV	DESCRIPTION	ISSUED FOR APPROVAL			
		By	Date	By	Date
A		PCS	25.01.2023	SK	25.01.2023
MARK		CREATED		CHECKED	

CLIENT: _____ DATE CREATED: 24.01.2023

PROJECT: Ebenezer Street DRAWN BY: PCS

CONTRACT NO: T8298 DRAWING NO: [BM.30] REV: A

ASSEMBLY / SUB ASSEMBLY STATUS	
1	THIS IS IT'S OWN ASSEMBLY

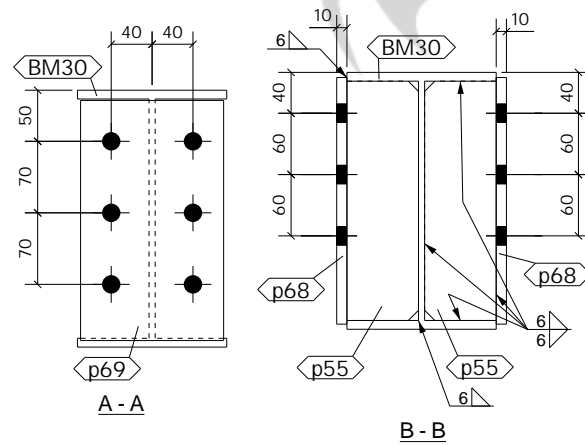
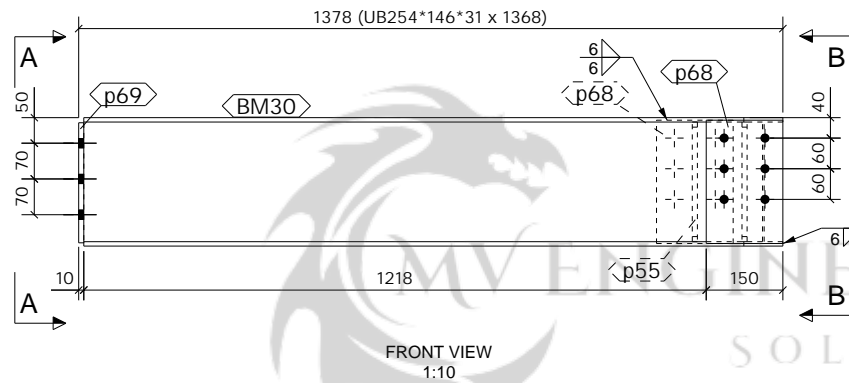
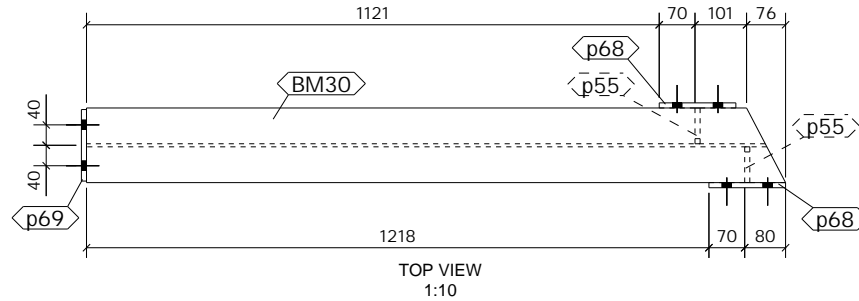

1 No. BEAM

REQUIRED AS DRAWN MARKED BM31

SHOP MATERIAL LIST FOR 1 ASSEMBLY

Mark	Size	Grade	No.	Length (mm)	Area (m ²)	Weight (kg)
BM30	UB254*146*31	S275	1	1368	1.438	40.9
p55	FLT10*70	S275	2	234	0.077	2.6
p68	FLT10*150	S275	2	241	0.160	5.7
p69	FLT10*140	S275	1	235	0.073	2.6
Total					1.749	51.7

GENERAL NOTES

All Holes to be 22 Dia UNO Slot hole length is to outside
All Welds to be 6 FW. UNO

All Steelwork Manufactured to:
BS EN 1090-2: Execution Class EXC2 U.N.O.

FINISH GALVANISED
LOT 0 QTY 1
PHASE 1 QTY 1

FABRICATION STATUS

Sawn by: _____ Date: _____
Fabricated by: _____ Date: _____
Welded by: _____ Date: _____
Loaded by: _____ Date: _____
Checked by: _____ Date: _____

REV	DESCRIPTION	ISSUED FOR APPROVAL			
		By	Date	By	Date
A		PCS	25.01.2023	SK	25.01.2023
MARK		CREATED		CHECKED	

CLIENT: DATE CREATED: 24.01.2023

PROJECT: Ebenezer Street DRAWN BY: PCS

CONTRACT NO: T8298 DRAWING NO: [BM.31] REV: A

ASSEMBLY / SUB ASSEMBLY STATUS	
1	THIS IS IT'S OWN ASSEMBLY

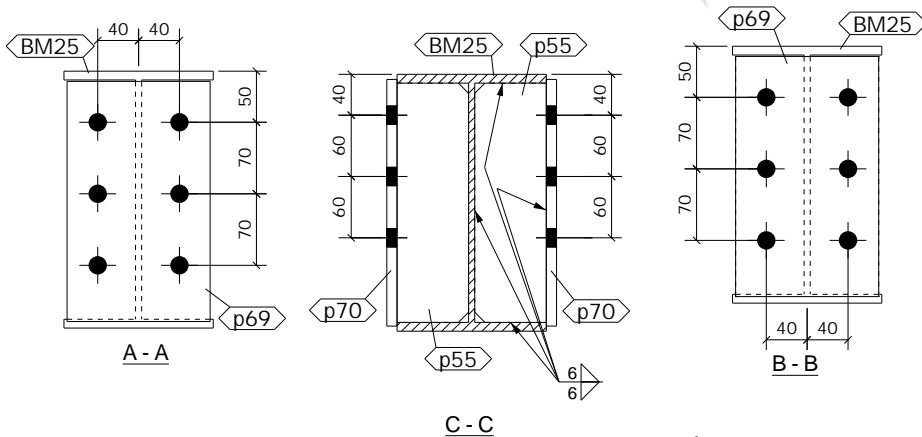
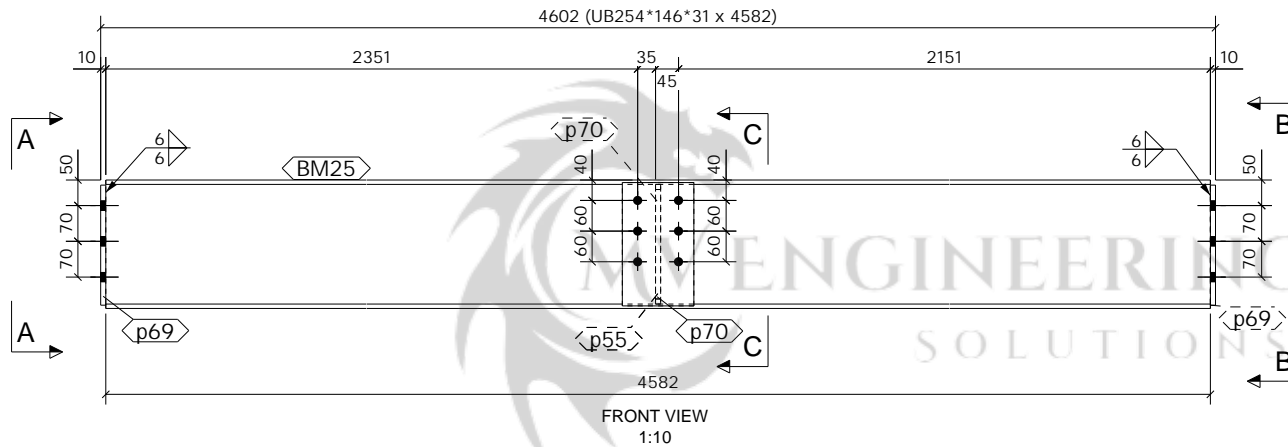
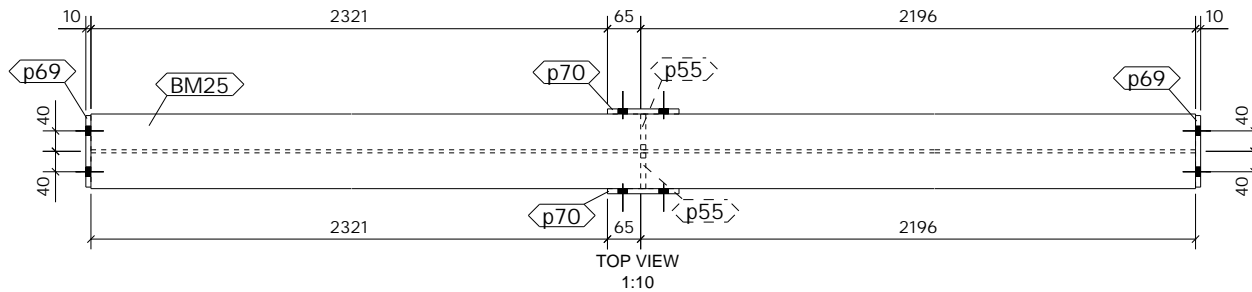

1 No. BEAM

REQUIRED AS DRAWN MARKED BM32

SHOP MATERIAL LIST FOR 1 ASSEMBLY

Mark	Size	Grade	No.	Length (mm)	Area (m ²)	Weight (kg)
BM25	UB254*146*31	S275	1	4582	4.934	140.9
p55	FLT10*70	S275	2	234	0.077	2.6
p69	FLT10*140	S275	2	235	0.147	5.2
p70	FLT10*140	S275	2	241	0.150	5.3
Total					5.308	154.0

GENERAL NOTES

All Holes to be 22 Dia UNO Slot hole length is to outside
 All Welds to be 6 FW. UNO

All Steelwork Manufactured to:
 BS EN 1090-2: Execution Class EXC2 U.N.O.

FINISH GALVANISED
 LOT 0 QTY 1
 PHASE 1 QTY 1

FABRICATION STATUS

Sawn by: _____ Date: _____
 Fabricated by: _____ Date: _____
 Welded by: _____ Date: _____
 Loaded by: _____ Date: _____
 Checked by: _____ Date: _____

A	ISSUED FOR APPROVAL	APPROVAL			
		PCS	Date	SK	Date
REV		By	Date	By	Date
MARK	DESCRIPTION	CREATED		CHECKED	

CLIENT: Ebenezzer Street DATE CREATED: 23.01.2023

PROJECT: Ebenezzer Street DRAWN BY: PCS

CONTRACT NO: T8298 DRAWING NO: [BM.32] REV: A

ASSEMBLY / SUB ASSEMBLY STATUS	
1	THIS IS IT'S OWN ASSEMBLY

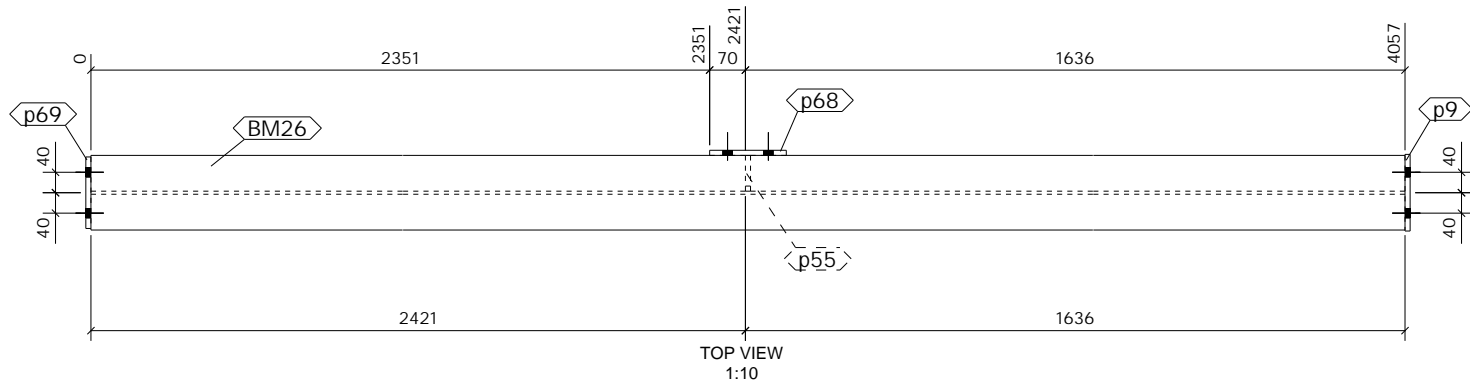

TOP VIEW
1:10

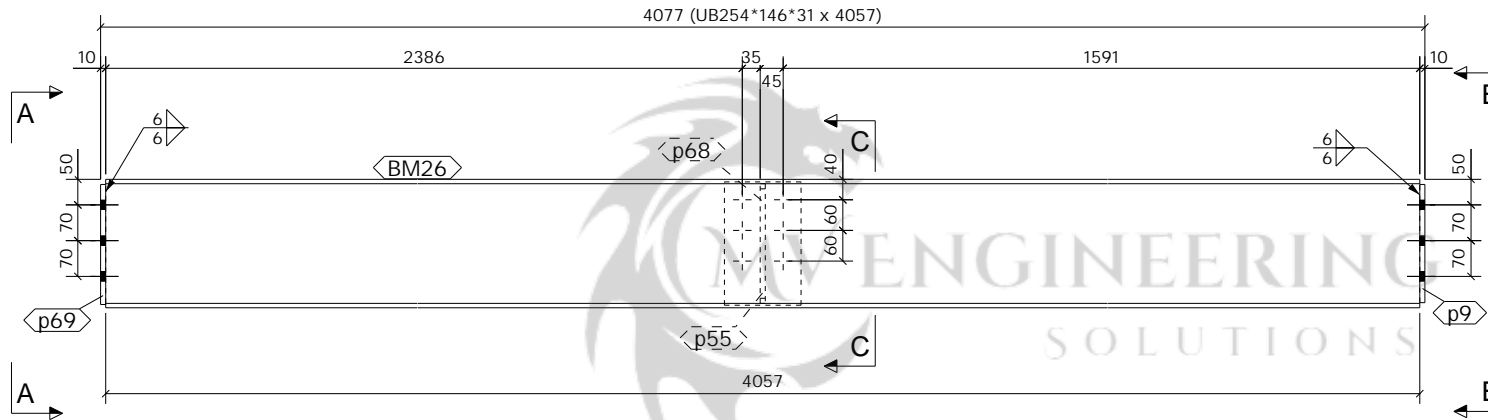

FRONT VIEW
1:10

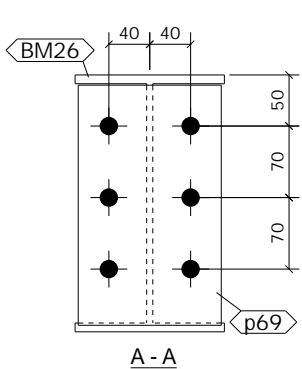

A - A

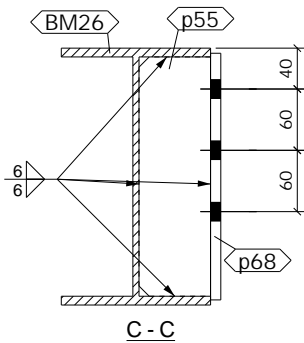

C - C

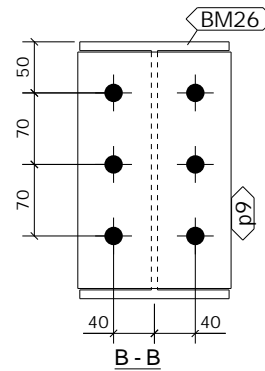

B - B

1 No. BEAM

REQUIRED AS DRAWN MARKED BM33

SHOP MATERIAL LIST FOR 1 ASSEMBLY

Mark	Size	Grade	No.	Length (mm)	Area (m ²)	Weight (kg)
BM26	UB254*146*31	S275	1	4057	4.370	124.8
p9	FLT10*150	S275	1	231	0.077	2.7
p55	FLT10*70	S275	1	234	0.039	1.3
p68	FLT10*150	S275	1	241	0.080	2.8
p69	FLT10*140	S275	1	235	0.073	2.6
Total					4.639	134.2

GENERAL NOTES

All Holes to be 22 Dia UNO Slot hole length is to outside
All Welds to be 6 FW. UNO

All Steelwork Manufactured to:
BS EN 1090-2: Execution Class **EXC2** U.N.O.

FINISH **GALVANISED**
LOT **0** QTY **1**
PHASE **1** QTY **1**

FABRICATION STATUS

Sawn by: _____ Date: _____
Fabricated by: _____ Date: _____
Welded by: _____ Date: _____
Loaded by: _____ Date: _____
Checked by: _____ Date: _____

REV	DESCRIPTION	ISSUED FOR APPROVAL			
		By	Date	By	Date
A		PCS	25.01.2023	SK	25.01.2023
MARK		CREATED		CHECKED	

CLIENT: Ebenezzer Street DATE CREATED: 23.01.2023

PROJECT: Ebenezzer Street DRAWN BY: PCS

CONTRACT NO: T8298 DRAWING NO: [BM.33] REV: A

ASSEMBLY / SUB ASSEMBLY STATUS	
1	THIS IS IT'S OWN ASSEMBLY

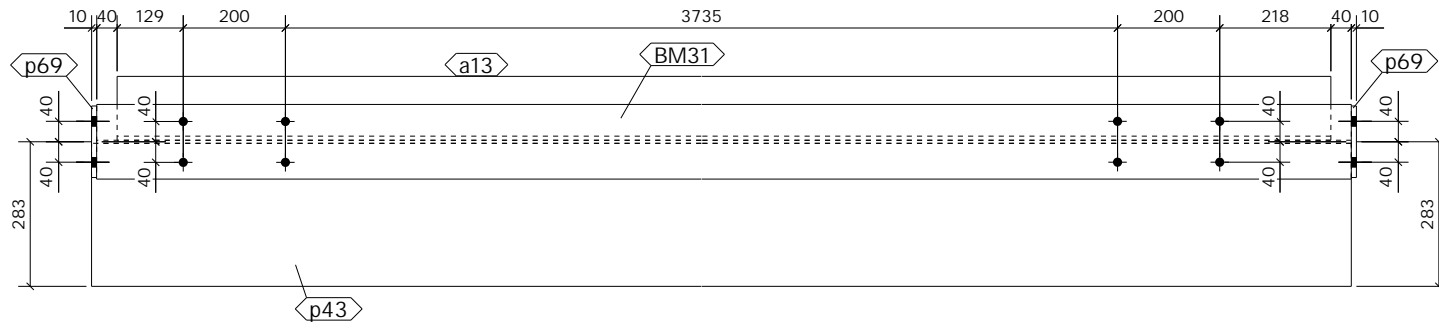

TOP VIEW
1:10

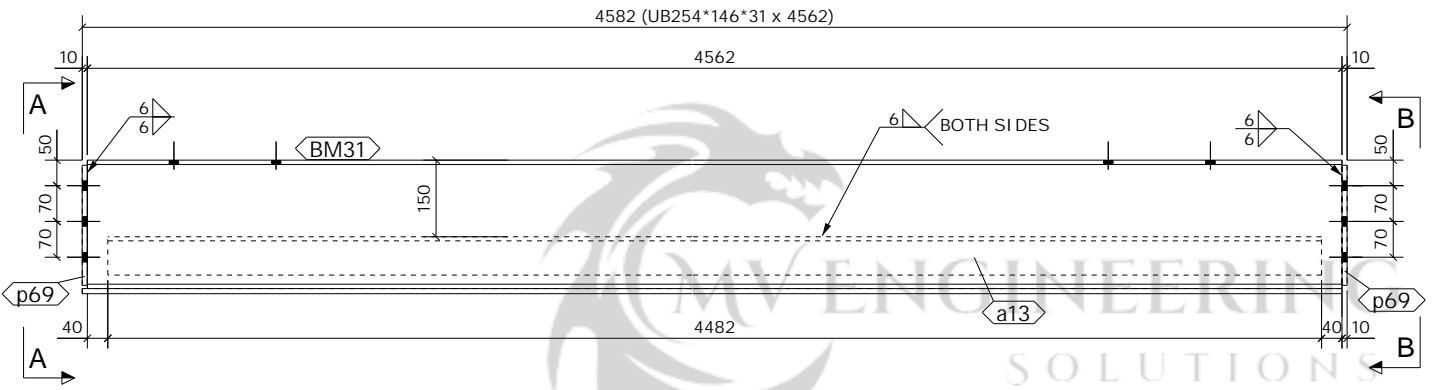

FRONT VIEW
1:10

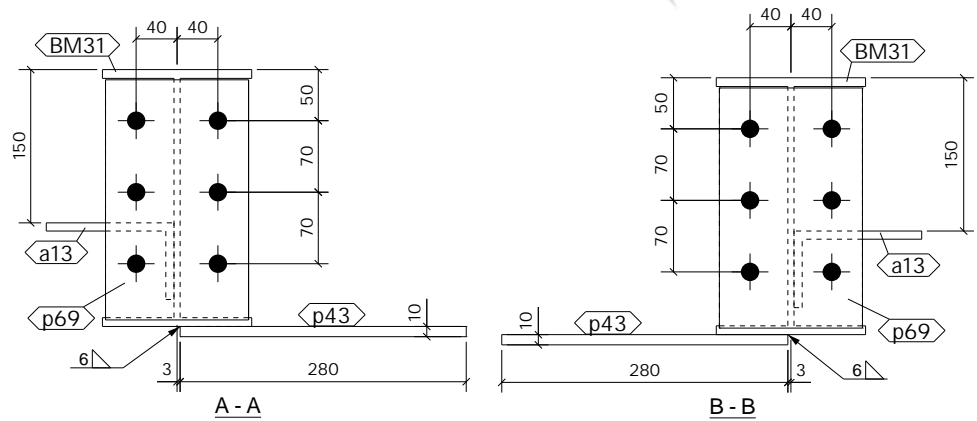

1 No. BEAM

REQUIRED AS DRAWN MARKED BM34

SHOP MATERIAL LIST FOR 1 ASSEMBLY

Mark	Size	Grade	No.	Length (mm)	Area (m ²)	Weight (kg)
BM31	UB254*146*31	S275	1	4562	4.913	140.3
a13	RSA125*75*8	S275	1	4482	1.796	54.0
p43	PL10*280	S275	1	4572	2.657	100.5
p69	FLT10*140	S275	2	235	0.147	5.2
				Total	9.513	300.0

GENERAL NOTES

All Holes to be **22** Dia UNO Slot hole length is to outside
 All Welds to be **6** FW. UNO

All Steelwork Manufactured to:
 BS EN 1090-2: Execution Class **EXC2** U.N.O.

FINISH **GALVANISED**
 LOT **0** QTY **1**
 PHASE **1** QTY **1**

FABRICATION STATUS

Sawn by: _____ Date: _____
 Fabricated by: _____ Date: _____
 Welded by: _____ Date: _____
 Loaded by: _____ Date: _____
 Checked by: _____ Date: _____

A	ISSUED FOR APPROVAL	REV			
		By	Date	By	Date
	PCS	25.01.2023	SK	25.01.2023	
MARK	DESCRIPTION	CREATED	CHECKED		

CLIENT: _____ DATE CREATED: 23.01.2023

PROJECT: Ebenezer Street DRAWN BY: PCS

CONTRACT NO: T8298 DRAWING NO: [BM.34] REV: A

ASSEMBLY / SUB ASSEMBLY STATUS	
1	THIS IS IT'S OWN ASSEMBLY

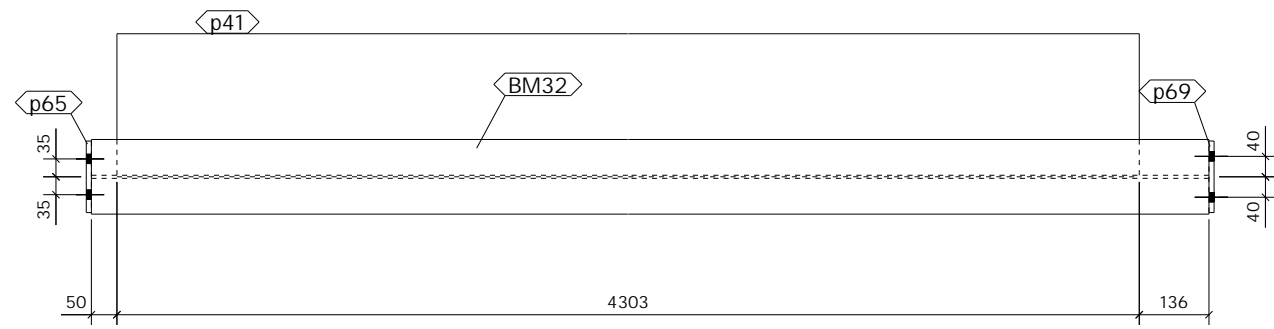

TOP VIEW
1:10

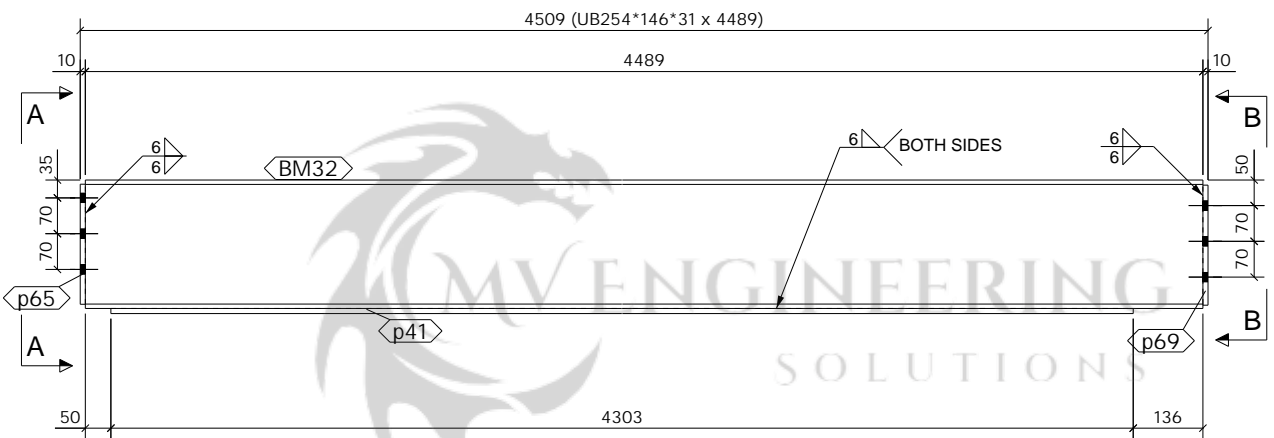

FRONT VIEW
1:10

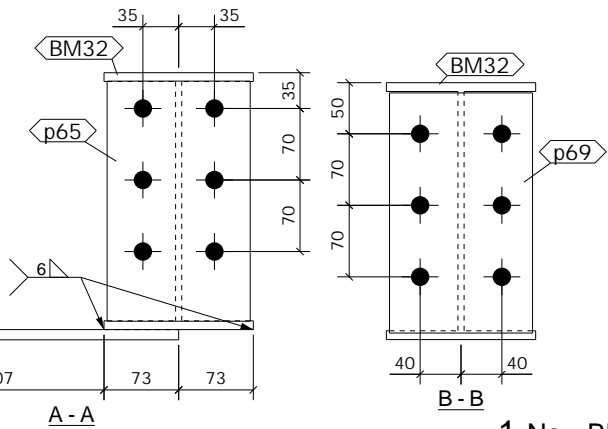

1 No. BEAM

REQUIRED AS DRAWN MARKED BM35

SHOP MATERIAL LIST FOR 1 ASSEMBLY

Mark	Size	Grade	No.	Length (mm)	Area (m ²)	Weight (kg)
BM32	UB254*146*31	S275	1	4489	4.835	138.1
p41	PL10*280	S275	1	4303	2.501	94.6
p65	FLT10*140	S275	1	235	0.073	2.6
p69	FLT10*140	S275	1	235	0.073	2.6
Total					7.482	237.8

GENERAL NOTES

All Holes to be 22 Dia UNO Slot hole length is to outside
All Welds to be 6 FW. UNO

All Steelwork Manufactured to:
BS EN 1090-2: Execution Class **EXC2** U.N.O.

FINISH **GALVANISED**
LOT **0** QTY **1**
PHASE **1** QTY **1**

FABRICATION STATUS

Sawn by: _____ Date: _____
Fabricated by: _____ Date: _____
Welded by: _____ Date: _____
Loaded by: _____ Date: _____
Checked by: _____ Date: _____

B	ISSUED FOR APPROVAL	PCS	01.02.2023	SK	01.02.2023
A	ISSUED FOR APPROVAL	PCS	25.01.2023	SK	25.01.2023
REV		By	Date	By	Date
MARK	DESCRIPTION	CREATED	CHECKED		

CLIENT: _____ DATE CREATED: 23.01.2023

PROJECT: Ebenezer Street DRAWN BY: PCS

CONTRACT NO: T8298 DRAWING NO: [BM.35] REV: B

ASSEMBLY / SUB ASSEMBLY STATUS	
1	THIS IS IT'S OWN ASSEMBLY

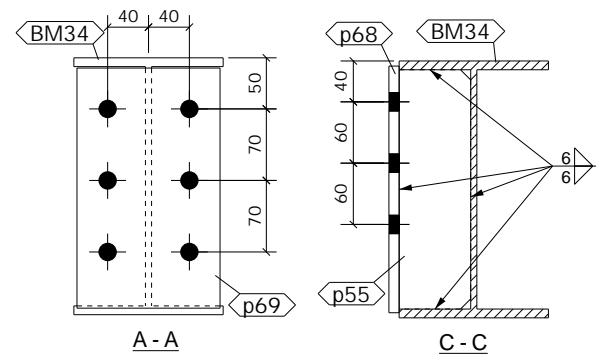
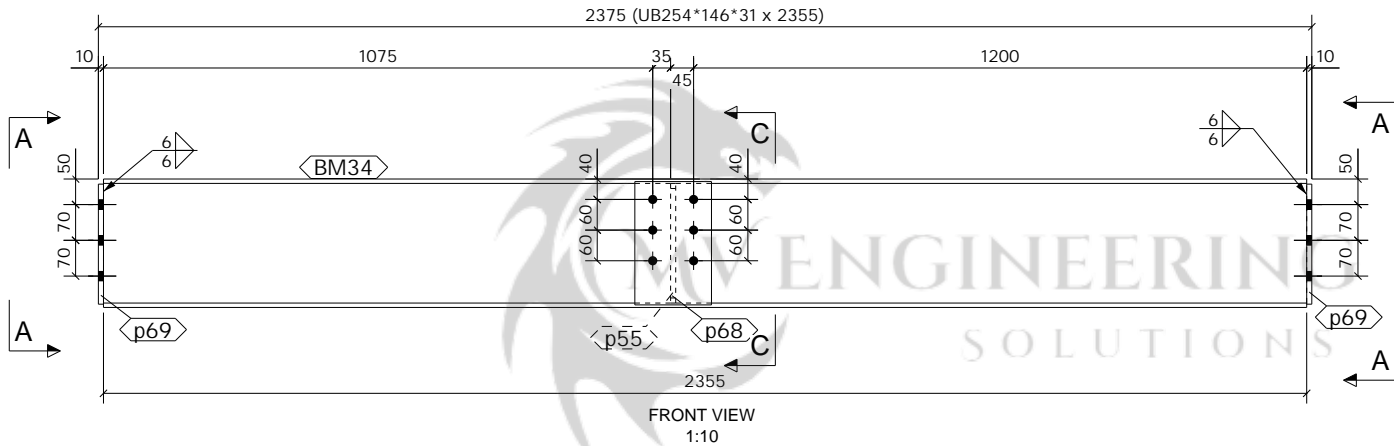
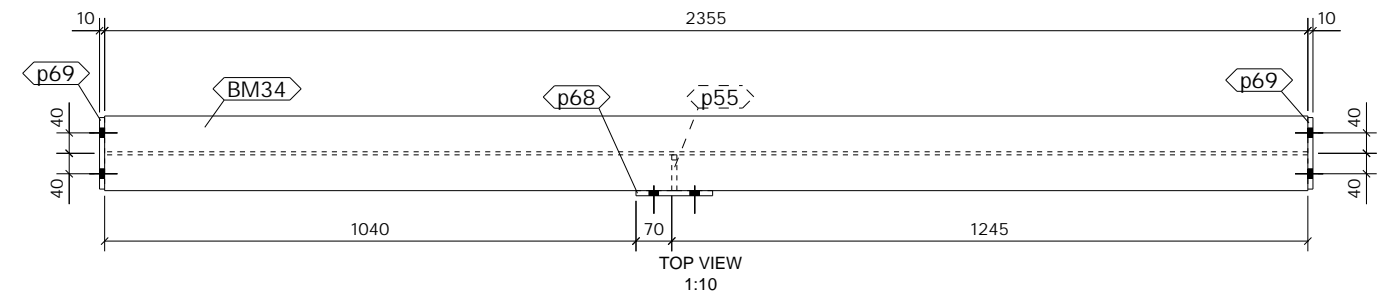

1 No. BEAM

REQUIRED AS DRAWN MARKED BM36

SHOP MATERIAL LIST FOR 1 ASSEMBLY

Mark	Size	Grade	No.	Length (mm)	Area (m ²)	Weight (kg)
BM34	UB254*146*31	S275	1	2355	2.540	72.4
p55	FLT10*70	S275	1	234	0.039	1.3
p68	FLT10*150	S275	1	241	0.080	2.8
p69	FLT10*140	S275	2	235	0.147	5.2
Total					2.805	81.7

GENERAL NOTES

All Holes to be **22 Dia UNO** Slot hole length is to outside
 All Welds to be **6 FW. UNO**

All Steelwork Manufactured to:
 BS EN 1090-2: Execution Class **EXC2** U.N.O.

FINISH **GALVANISED**
 LOT **0** QTY **1**
 PHASE **1** QTY **1**

FABRICATION STATUS

Sawn by: _____ Date: _____
 Fabricated by: _____ Date: _____
 Welded by: _____ Date: _____
 Loaded by: _____ Date: _____
 Checked by: _____ Date: _____

REV	DESCRIPTION	By	Date	By	Date
A	ISSUED FOR APPROVAL	PCS	25.01.2023	SK	25.01.2023
MARK	DESCRIPTION	CREATED	CHECKED		

CLIENT: _____ **DATE CREATED:** 23.01.2023

PROJECT: Ebenezer Street **DRAWN BY:** PCS

CONTRACT NO: T8298 **DRAWING NO:** [BM.36] **REV:** A

ASSEMBLY / SUB ASSEMBLY STATUS	
1	THIS IS IT'S OWN ASSEMBLY

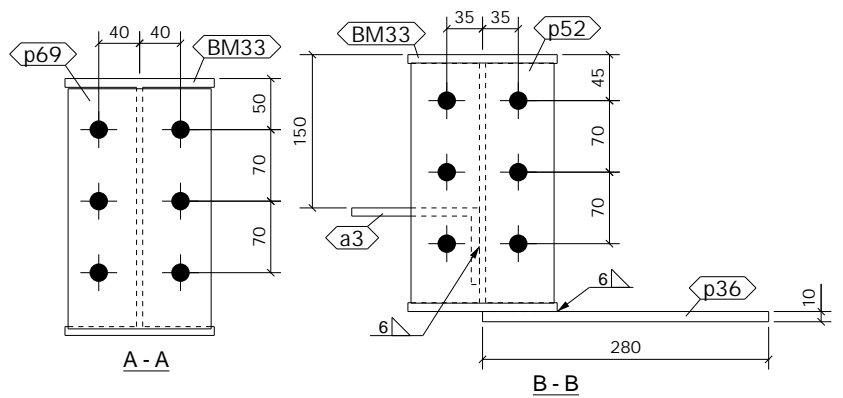
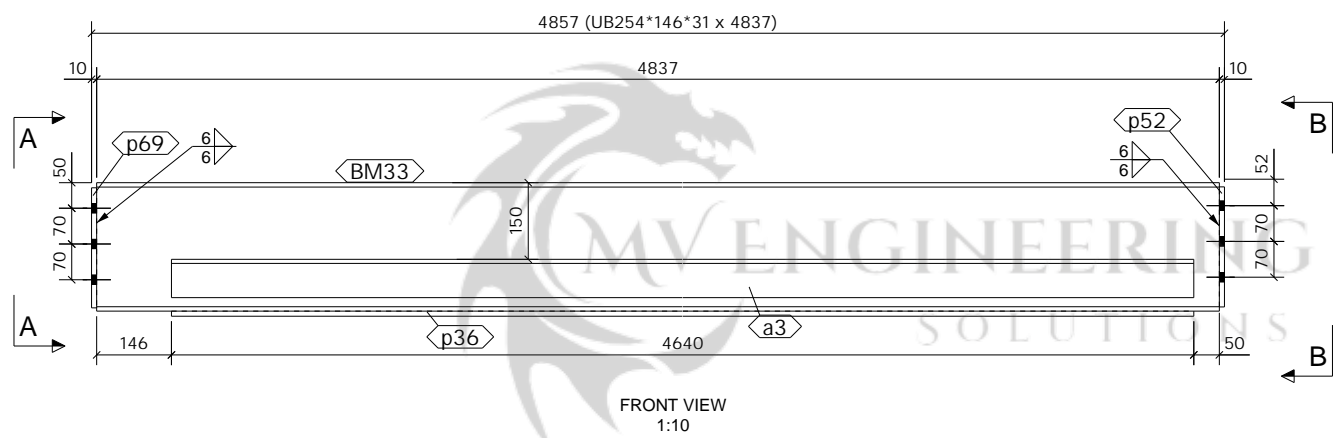
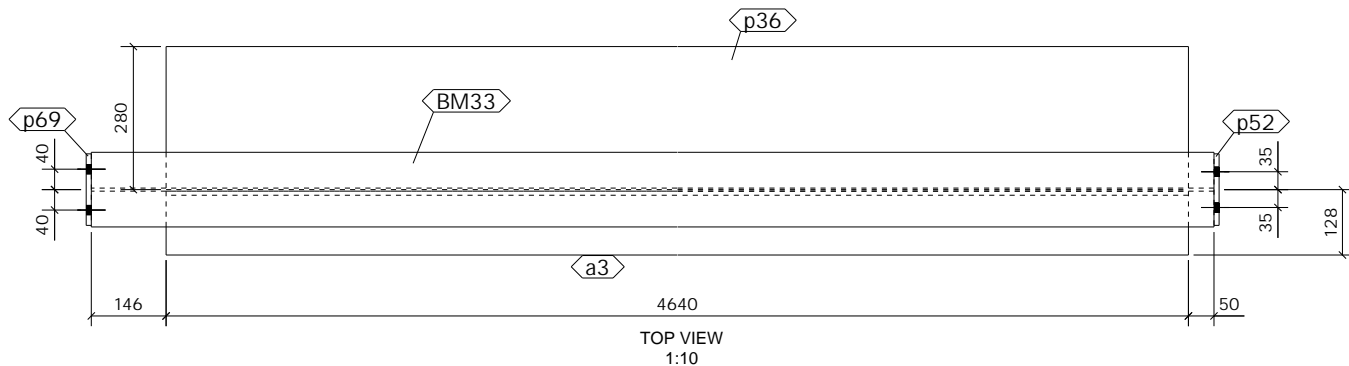

1 No. BEAM

REQUIRED AS DRAWN MARKED BM37

SHOP MATERIAL LIST FOR 1 ASSEMBLY

Mark	Size	Grade	No.	Length (mm)	Area (m ²)	Weight (kg)
BM33	UB254*146*31	S275	1	4837	5.208	148.8
a3	RSA125*75*8	S275	1	4640	1.859	56.0
p36	PL10*280	S275	1	4640	2.697	102.0
p52	FLT10*140	S275	1	235	0.073	2.6
p69	FLT10*140	S275	1	235	0.073	2.6
Total					9.911	311.9

GENERAL NOTES

All Holes to be **22** Dia UNO Slot hole length is to outside
 All Welds to be **6** FW. UNO

All Steelwork Manufactured to:
 BS EN 1090-2: Execution Class **EXC2** U.N.O.

FINISH **GALVANISED**

LOT **0** QTY **1**
 PHASE **1** QTY **1**

FABRICATION STATUS

Sawn by: _____ Date: _____
 Fabricated by: _____ Date: _____
 Welded by: _____ Date: _____
 Loaded by: _____ Date: _____
 Checked by: _____ Date: _____

REV	DESCRIPTION	ISSUED FOR APPROVAL			
		By	Date	By	Date
A		PCS	25.01.2023	SK	25.01.2023
MARK		CREATED		CHECKED	

CLIENT: Ebenezzer Street **DATE CREATED:** 23.01.2023

PROJECT: Ebenezzer Street **DRAWN BY:** PCS

CONTRACT NO: T8298 **DRAWING NO:** [BM.37] **REV:** A

ASSEMBLY / SUB ASSEMBLY STATUS	
1	THIS IS IT'S OWN ASSEMBLY

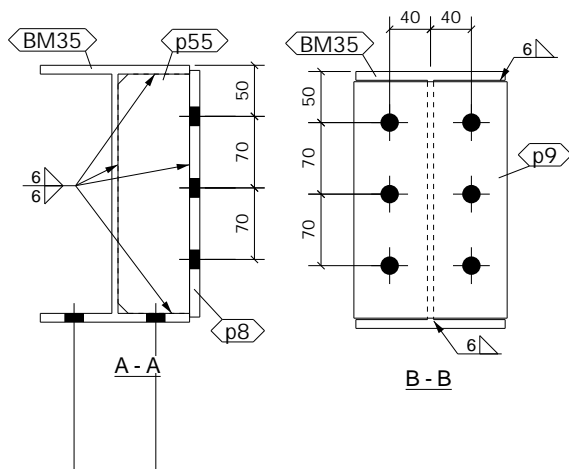
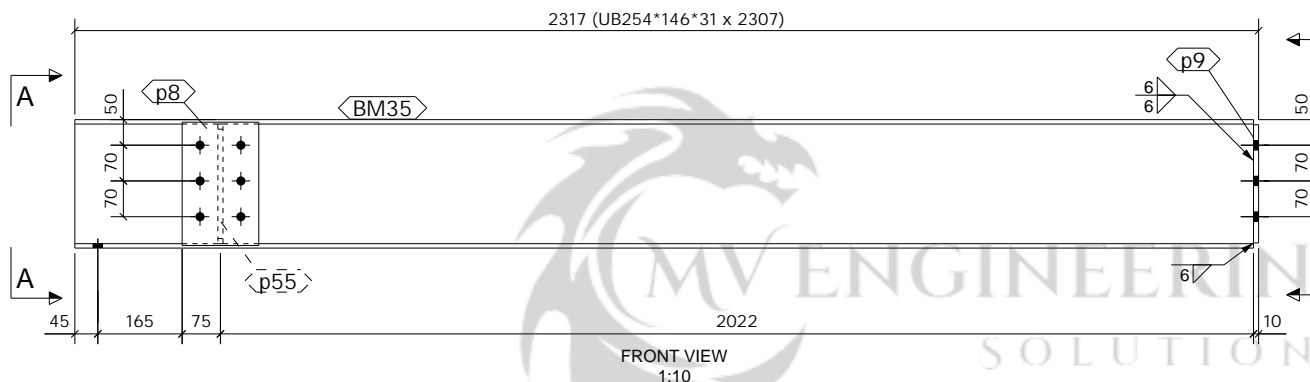
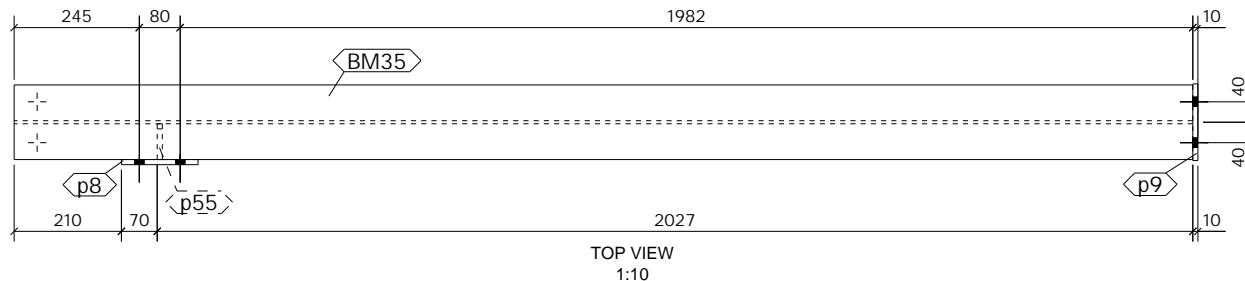

1 No. BEAM

REQUIRED AS DRAWN MARKED BM38

SHOP MATERIAL LIST FOR 1 ASSEMBLY

Mark	Size	Grade	No.	Length (mm)	Area (m ²)	Weight (kg)
BM35	UB254*146*31	S275	1	2307	2.488	71.0
p8	FLT10*150	S275	1	241	0.080	2.8
p9	FLT10*150	S275	1	231	0.077	2.7
p55	FLT10*70	S275	1	234	0.039	1.3
Total					2.684	77.8

GENERAL NOTES

All Holes to be **22 Dia UNO** Slot hole length is to outside
 All Welds to be **6 FW. UNO**

All Steelwork Manufactured to:
 BS EN 1090-2: Execution Class **EXC2** U.N.O.

FINISH **GALVANISED**
 LOT **0** QTY **1**
 PHASE **1** QTY **1**

FABRICATION STATUS

Sawn by: _____ Date: _____
 Fabricated by: _____ Date: _____
 Welded by: _____ Date: _____
 Loaded by: _____ Date: _____
 Checked by: _____ Date: _____

A	ISSUED FOR APPROVAL	DATE			
		By	Date	By	Date
	PCS	25.01.2023	SK	25.01.2023	
REV	DESCRIPTION	CREATED	CHECKED		

CLIENT: Ebenezzer Street **DATE CREATED:** 23.01.2023

PROJECT: Ebenezzer Street **DRAWN BY:** PCS

CONTRACT NO: T8298 **DRAWING NO:** [BM.38] **REV:** A

ASSEMBLY / SUB ASSEMBLY STATUS	
1	THIS IS IT'S OWN ASSEMBLY

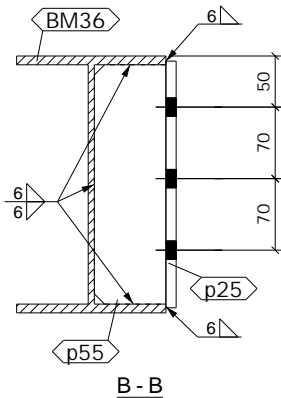
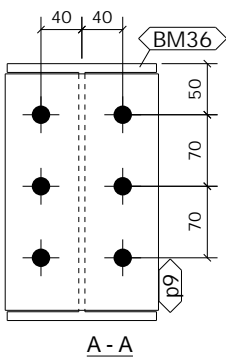
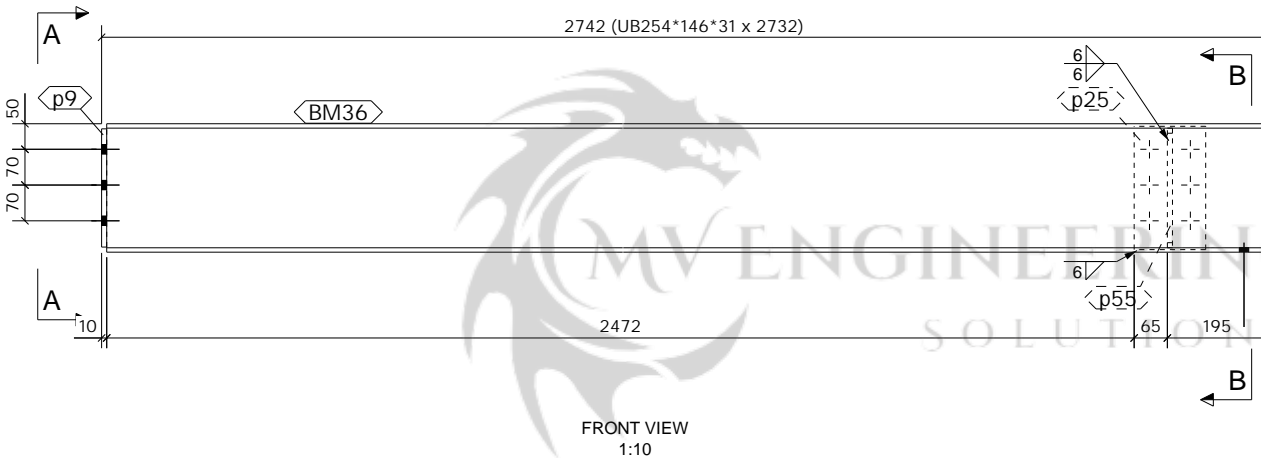
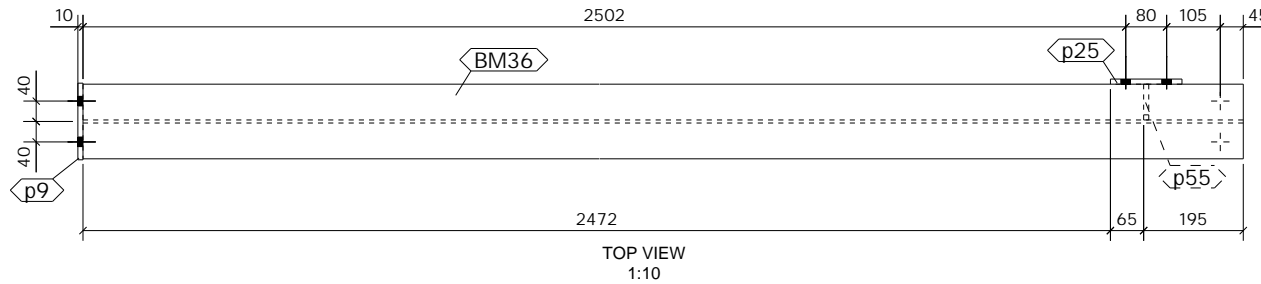

1 No. BEAM

REQUIRED AS DRAWN MARKED BM39

SHOP MATERIAL LIST FOR 1 ASSEMBLY

Mark	Size	Grade	No.	Length (mm)	Area (m ²)	Weight (kg)
BM36	UB254*146*31	S275	1	2732	2.945	84.0
p9	FLT10*150	S275	1	231	0.077	2.7
p25	FLT10*140	S275	1	241	0.075	2.7
p55	FLT10*70	S275	1	234	0.039	1.3
Total					3.136	90.7

GENERAL NOTES

All Holes to be **22** Dia UNO Slot hole length is to outside
 All Welds to be **6** FW. UNO

All Steelwork Manufactured to:
 BS EN 1090-2: Execution Class **EXC2** U.N.O.

FINISH **GALVANISED**
 LOT **0** QTY **1**
 PHASE **1** QTY **1**

FABRICATION STATUS

Sawn by: _____ Date: _____
 Fabricated by: _____ Date: _____
 Welded by: _____ Date: _____
 Loaded by: _____ Date: _____
 Checked by: _____ Date: _____

REV	DESCRIPTION	ISSUED FOR APPROVAL			
		By	Date	By	Date
A		PCS	25.01.2023	SK	25.01.2023
MARK		CREATED		CHECKED	

CLIENT: Ebenezzer Street **DATE CREATED:** 23.01.2023

PROJECT: Ebenezzer Street **DRAWN BY:** PCS

CONTRACT NO: T8298 **DRAWING NO:** [BM.39] **REV:** A

ASSEMBLY / SUB ASSEMBLY STATUS	
1	THIS IS IT'S OWN ASSEMBLY

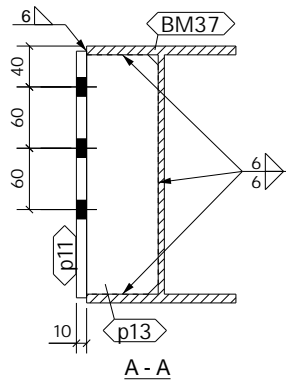
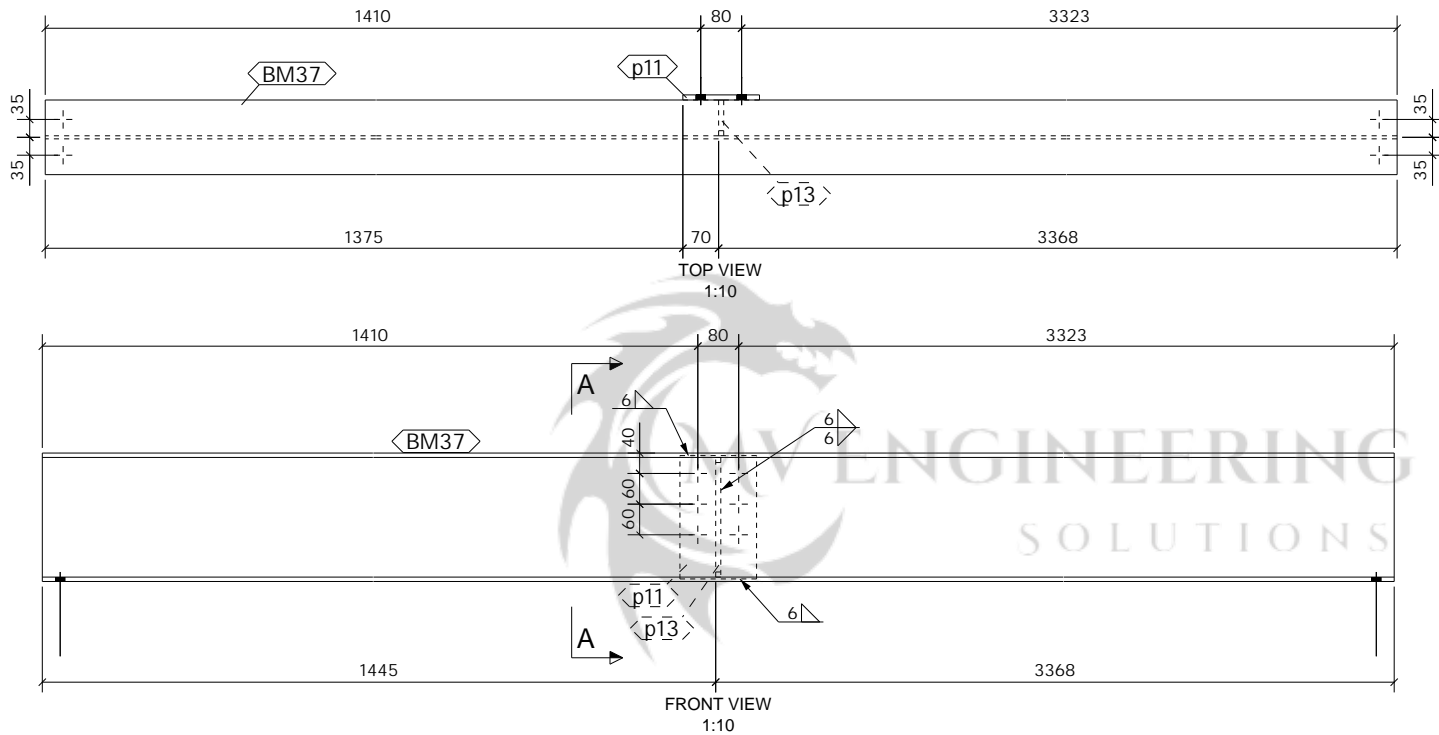

1 No. BEAM

REQUIRED AS DRAWN MARKED BM40

ASSEMBLY / SUB ASSEMBLY STATUS	
1	THIS IS IT'S OWN ASSEMBLY

SHOP MATERIAL LIST FOR 1 ASSEMBLY

Mark	Size	Grade	No.	Length (mm)	Area (m ²)	Weight (kg)
BM37	UB254*146*31	S275	1	4813	5.182	148.0
p11	FLT10*150	S275	1	241	0.080	2.8
p13	FLT10*70	S275	1	234	0.039	1.3
Total					5.301	152.1

GENERAL NOTES

All Holes to be **22** Dia UNO Slot hole length is to outside
 All Welds to be **6** FW. UNO

All Steelwork Manufactured to:
 BS EN 1090-2: Execution Class **EXC2** U.N.O.

FINISH **S.B. & PRIME**
 LOT **0** QTY **1**
 PHASE **1** QTY **1**

FABRICATION STATUS

Sawn by: _____ Date: _____
 Fabricated by: _____ Date: _____
 Welded by: _____ Date: _____
 Loaded by: _____ Date: _____
 Checked by: _____ Date: _____

REV	DESCRIPTION	ISSUED FOR APPROVAL			
		By	Date	By	Date
A		PCS	25.01.2023	SK	25.01.2023
MARK		CREATED		CHECKED	

CLIENT: Ebenezzer Street **DATE CREATED:** 23.01.2023

PROJECT: Ebenezzer Street **DRAWN BY:** PCS

CONTRACT NO: T8298 **DRAWING NO:** [BM.40] **REV:** A

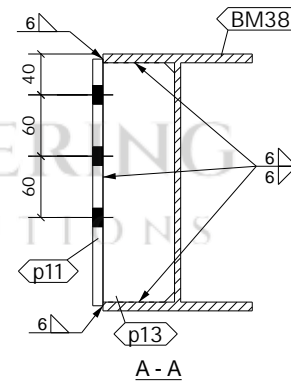
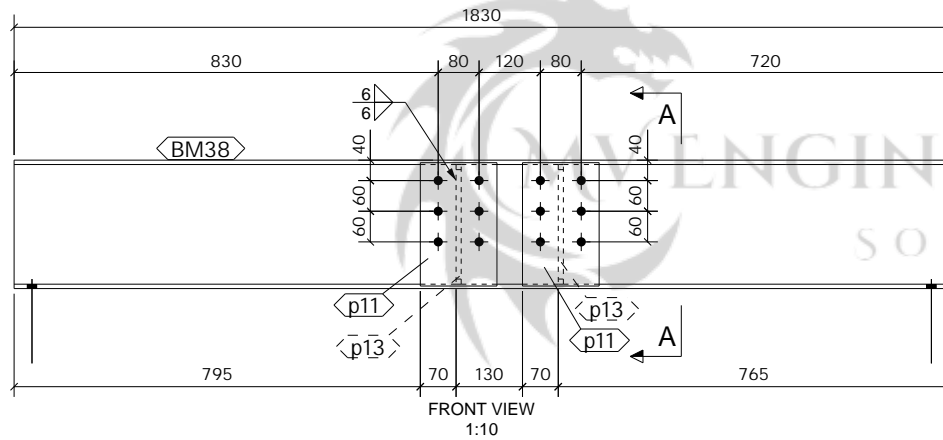
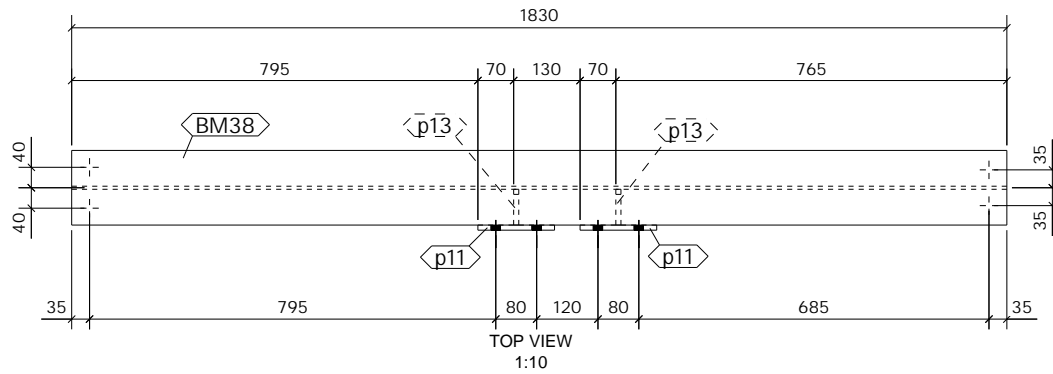

SHOP MATERIAL LIST FOR 1 ASSEMBLY

Mark	Size	Grade	No.	Length (mm)	Area (m ²)	Weight (kg)
BM38	UB254*146*31	S275	1	1830	1.976	56.3
p11	FLT10*150	S275	2	241	0.160	5.7
p13	FLT10*70	S275	2	234	0.077	2.6
Total					2.213	64.5

GENERAL NOTES

All Holes to be **22** Dia UNO Slot hole length is to outside
 All Welds to be **6** FW. UNO

All Steelwork Manufactured to:
 BS EN 1090-2: Execution Class **EXC2** U.N.O.

FINISH **S.B. & PRIME**
 LOT **0** QTY **1**
 PHASE **1** QTY **1**

FABRICATION STATUS

Sawn by: _____ Date: _____
 Fabricated by: _____ Date: _____
 Welded by: _____ Date: _____
 Loaded by: _____ Date: _____
 Checked by: _____ Date: _____

REV	DESCRIPTION	ISSUED FOR APPROVAL			
		By	Date	By	Date
A		PCS	25.01.2023	SK	25.01.2023
MARK		CREATED		CHECKED	

CLIENT: _____ **DATE CREATED:** 23.01.2023

PROJECT: Ebenezer Street **DRAWN BY:** PCS

CONTRACT NO: T8298 **DRAWING NO:** [BM.41] **REV:** A

1 No. BEAM

REQUIRED AS DRAWN MARKED BM41

ASSEMBLY / SUB ASSEMBLY STATUS	
1	THIS IS IT'S OWN ASSEMBLY

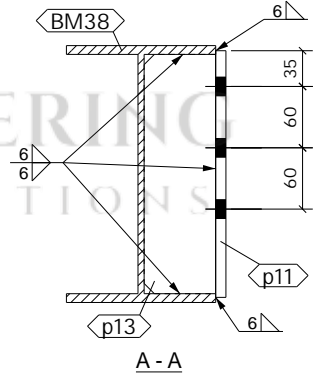
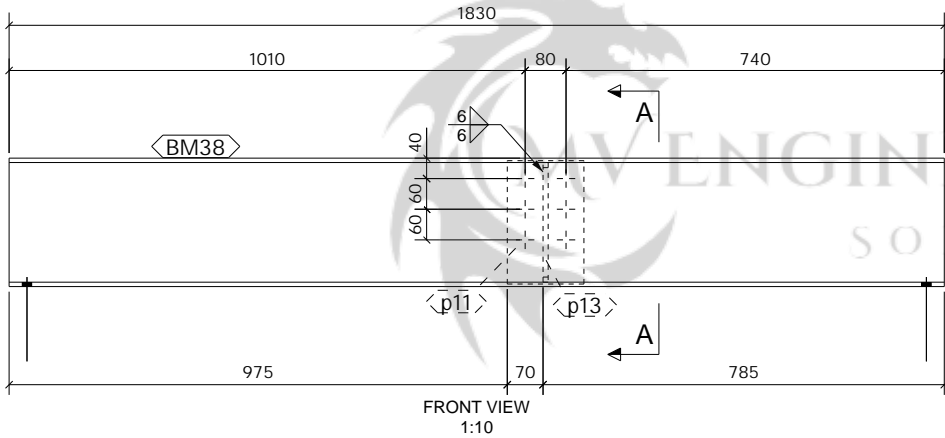
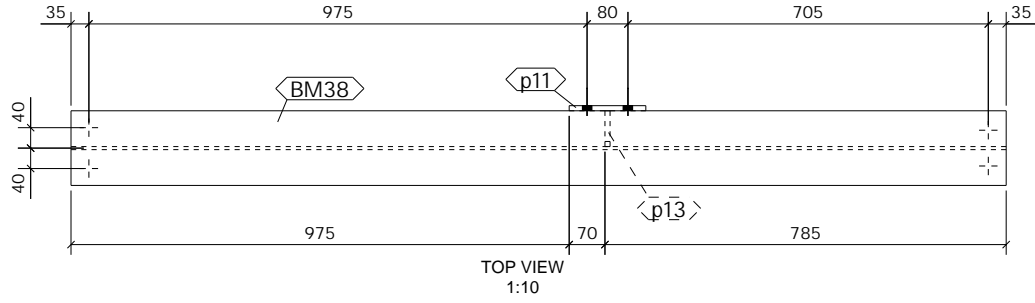

SHOP MATERIAL LIST FOR 1 ASSEMBLY						
Mark	Size	Grade	No.	Length (mm)	Area (m ²)	Weight (kg)
BM38	UB254*146*31	S275	1	1830	1.976	56.3
p11	FLT10*150	S275	1	241	0.080	2.8
p13	FLT10*70	S275	1	234	0.039	1.3
Total					2.095	60.4

GENERAL NOTES

All Holes to be **22** Dia UNO Slot hole length is to outside
 All Welds to be **6** FW. UNO

All Steelwork Manufactured to:
 BS EN 1090-2: Execution Class **EXC2** U.N.O.

FINISH **S.B. & PRIME**

LOT **0** QTY **1**

PHASE **1** QTY **1**

FABRICATION STATUS	
Sawn by: _____	Date: _____
Fabricated by: _____	Date: _____
Welded by: _____	Date: _____
Loaded by: _____	Date: _____
Checked by: _____	Date: _____

A	ISSUED FOR APPROVAL	BY		DATE	
		PCS	25.01.2023	SK	25.01.2023
REV	DESCRIPTION	By	Date	By	Date
MARK	DESCRIPTION	CREATED		CHECKED	

CLIENT: _____ **DATE CREATED:** 23.01.2023

PROJECT: Ebenezer Street **DRAWN BY:** PCS

CONTRACT NO: T8298 **DRAWING NO:** [BM.42] **REV:** A

1 No. BEAM

REQUIRED AS DRAWN MARKED BM42

ASSEMBLY / SUB ASSEMBLY STATUS	
1	THIS IS IT'S OWN ASSEMBLY

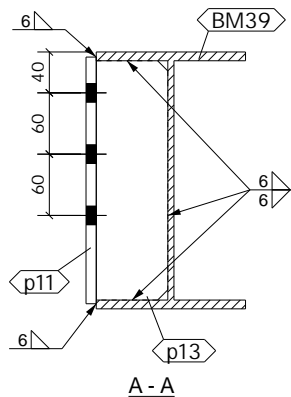
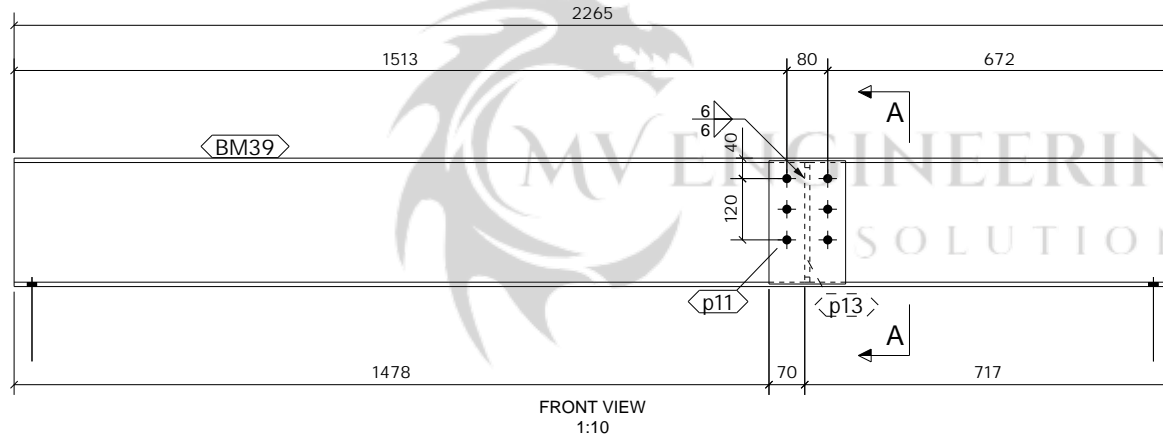
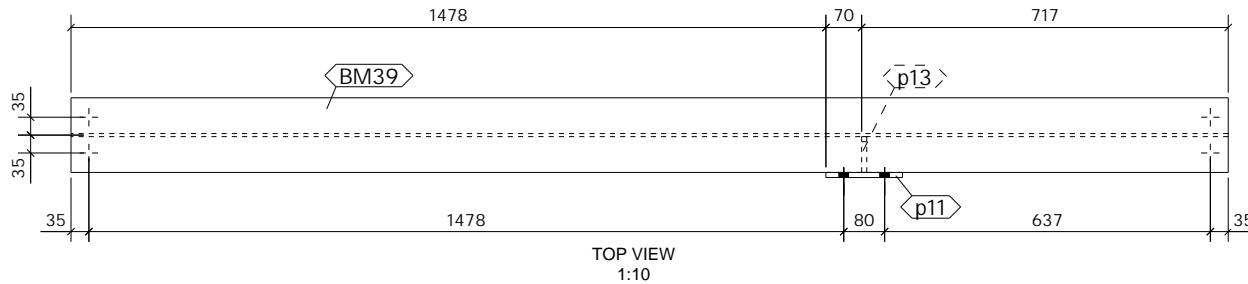

1 No. BEAM

REQUIRED AS DRAWN MARKED BM43

ASSEMBLY / SUB ASSEMBLY STATUS	
1	THIS IS IT'S OWN ASSEMBLY

SHOP MATERIAL LIST FOR 1 ASSEMBLY

Mark	Size	Grade	No.	Length	Area	Weight
				(mm)	(m) ²	(kg)
BM39	UB254*146*31	S275	1	2265	2.443	69.7
p11	FLT10*150	S275	1	241	0.080	2.8
p13	FLT10*70	S275	1	234	0.039	1.3
				Total	2.562	73.8

GENERAL NOTES

All Holes to be **22 Dia UNO** Slot hole length is to outside
 All Welds to be **6 FW. UNO**

All Steelwork Manufactured to:
 BS EN 1090-2: Execution Class **EXC2** U.N.O.

FINISH **S.B. & PRIME**
 LOT **0** QTY **1**
 PHASE **1** QTY **1**

FABRICATION STATUS

Sawn by: _____ Date: _____
 Fabricated by: _____ Date: _____
 Welded by: _____ Date: _____
 Loaded by: _____ Date: _____
 Checked by: _____ Date: _____

REV	DESCRIPTION	ISSUED FOR APPROVAL			
		By	Date	By	Date
A		PCS	25.01.2023	SK	25.01.2023
MARK		CREATED		CHECKED	

CLIENT: Ebenezzer Street **DATE CREATED:** 23.01.2023

PROJECT: Ebenezzer Street **DRAWN BY:** PCS

CONTRACT NO: T8298 **DRAWING NO:** [BM.43] **REV:** A

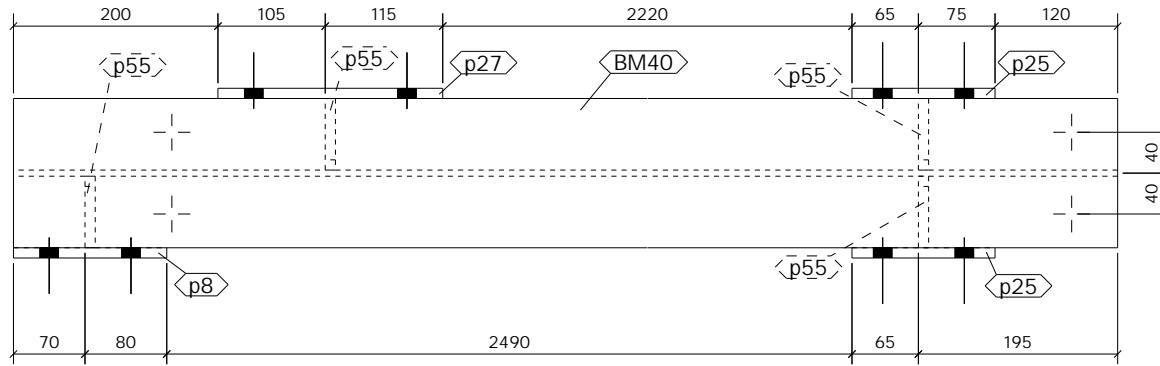

TOP VIEW
1:5

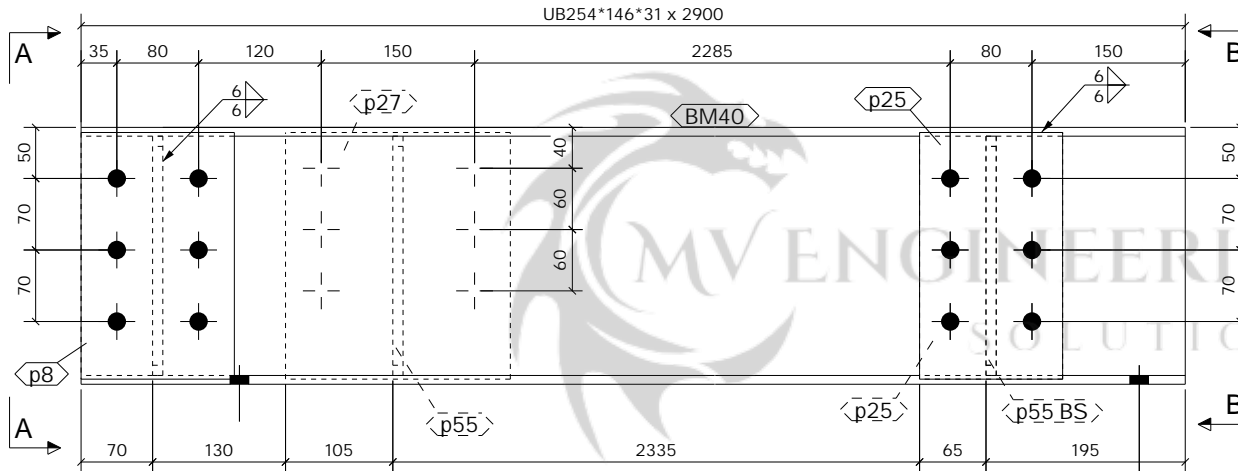

FRONT VIEW
1:5

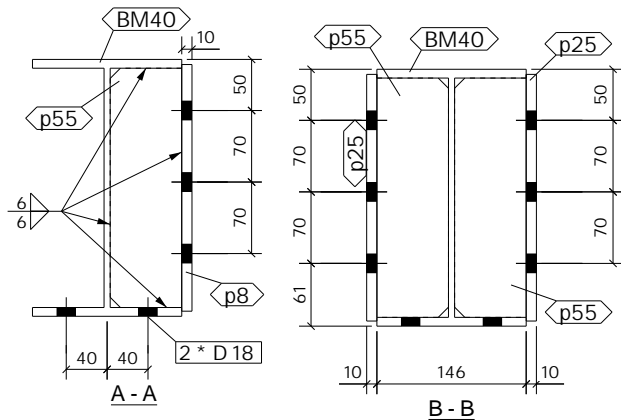

1 No. BEAM

REQUIRED AS DRAWN MARKED BM44

SHOP MATERIAL LIST FOR 1 ASSEMBLY

Mark	Size	Grade	No.	Length (mm)	Area (m ²)	Weight (kg)
BM40	UB254*146*31	S275	1	2900	3.126	89.2
p8	FLT10*150	S275	1	241	0.080	2.8
p25	FLT10*140	S275	2	241	0.150	5.3
p27	FLT10*220	S275	1	241	0.115	4.2
p55	FLT10*70	S275	4	234	0.154	5.1
				Total	3.626	106.6

GENERAL NOTES

All Holes to be 22 Dia UNO Slot hole length is to outside
All Welds to be 6 FW. UNO

All Steelwork Manufactured to:
BS EN 1090-2: Execution Class **EXC2** U.N.O.

FINISH **GALVANISED**
LOT 0 QTY 1
PHASE 1 QTY 1

FABRICATION STATUS

Sawn by: _____ Date: _____
Fabricated by: _____ Date: _____
Welded by: _____ Date: _____
Loaded by: _____ Date: _____
Checked by: _____ Date: _____

REV	DESCRIPTION	ISSUED FOR APPROVAL			
		By	Date	By	Date
A		PCS	25.01.2023	SK	25.01.2023
MARK	CREATED	CHECKED			

CLIENT: DATE CREATED:
Ebenezer Street 23.01.2023

PROJECT: DRAWN BY:
Ebenezer Street PCS

CONTRACT NO: DRAWING NO: REV:
T8298 [BM.44] A

ASSEMBLY / SUB ASSEMBLY STATUS
1 THIS IS IT'S OWN ASSEMBLY

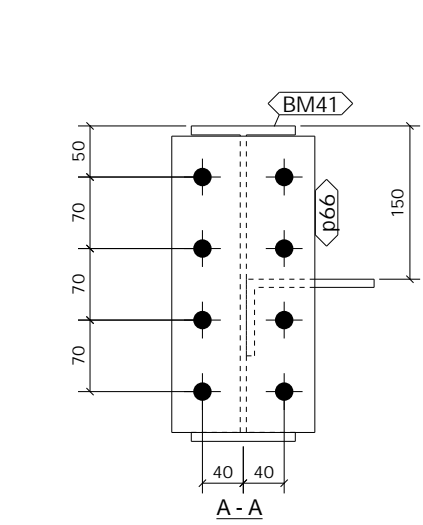
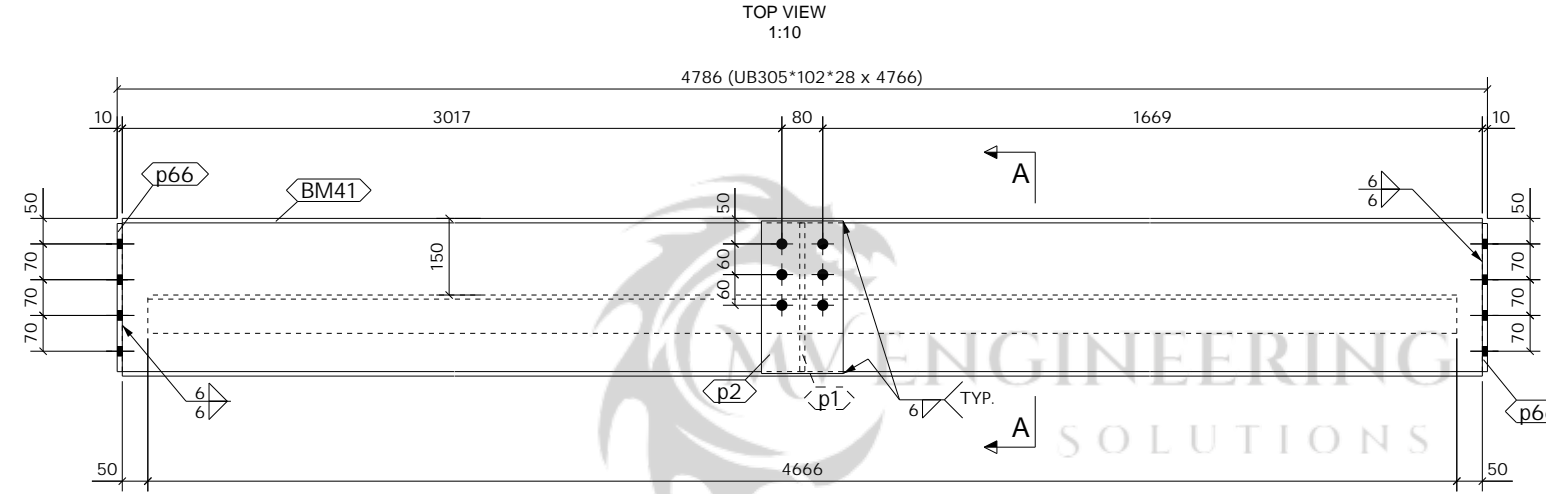
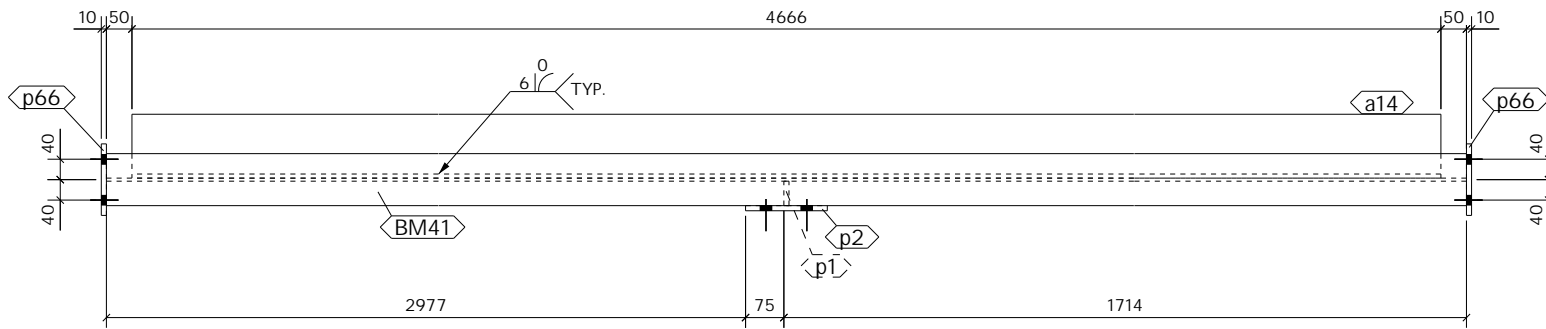

1 No. BEAM

REQUIRED AS DRAWN MARKED BM45

SHOP MATERIAL LIST FOR 1 ASSEMBLY

Mark	Size	Grade	No.	Length (mm)	Area (m ²)	Weight (kg)
BM41	UB305*102*28	S275	1	4766	4.833	132.4
a14	RSA125*75*8	S275	1	4666	1.869	56.3
p1	PLT10*47.9	S275	1	291	0.035	1.1
p2	PLT10*160	S275	1	299	0.105	3.8
p66	FLT10*140	S275	2	290	0.180	6.4
				Total	7.021	199.8

GENERAL NOTES

All Holes to be **22** Dia UNO Slot hole length is to outside
 All Welds to be **6** FW. UNO

All Steelwork Manufactured to:
 BS EN 1090-2: Execution Class **EXC2** U.N.O.

FINISH **GALVANISED**

LOT **0** QTY **1**
 PHASE **1** QTY **1**

FABRICATION STATUS

Sawn by: _____ Date: _____
 Fabricated by: _____ Date: _____
 Welded by: _____ Date: _____
 Loaded by: _____ Date: _____
 Checked by: _____ Date: _____

REV	DESCRIPTION	ISSUED FOR APPROVAL			
		By	Date	By	Date
A		PCS	25.01.2023	SK	25.01.2023
MARK		CREATED		CHECKED	

CLIENT: Ebenezzer Street **DATE CREATED:** 23.01.2023

PROJECT: Ebenezzer Street **DRAWN BY:** PCS

CONTRACT NO: T8298 **DRAWING NO:** [BM.45] **REV:** A

ASSEMBLY / SUB ASSEMBLY STATUS	
1	THIS IS IT'S OWN ASSEMBLY

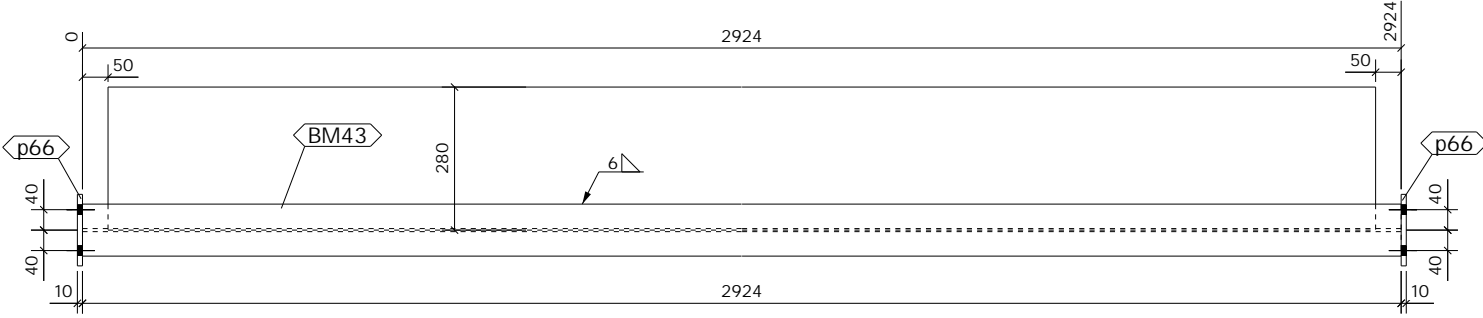

TOP VIEW
1:10

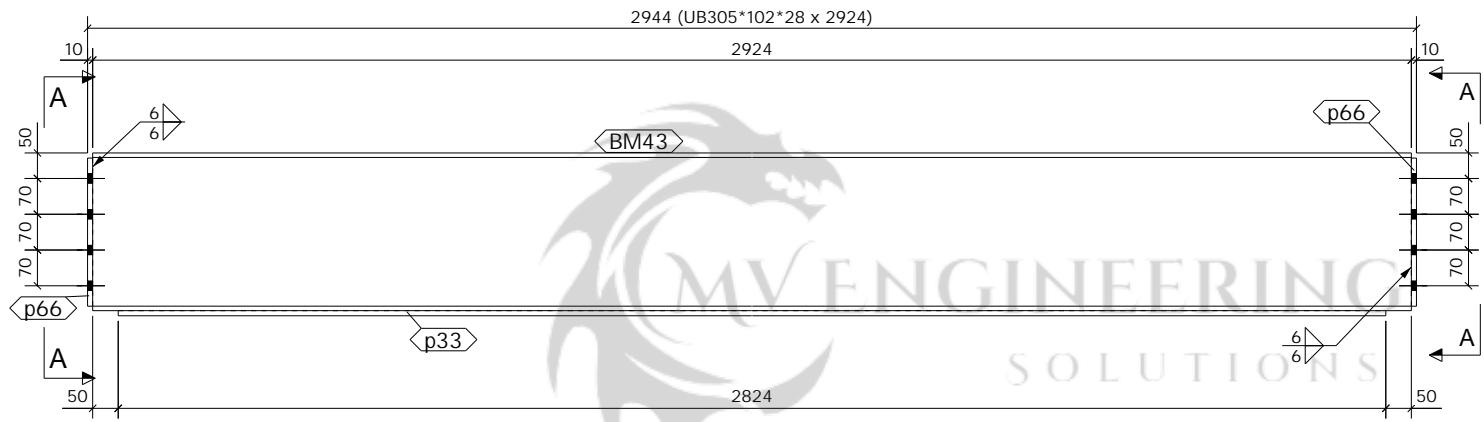

FRONT VIEW
1:10

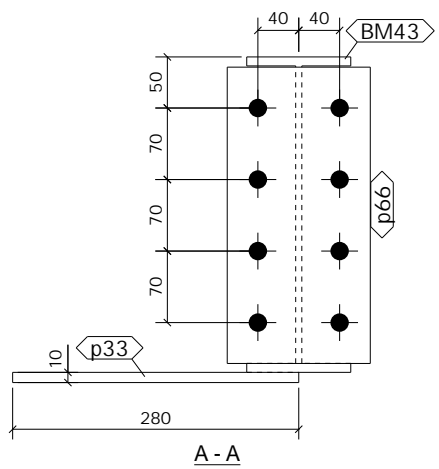

A - A

1 No. BEAM

REQUIRED AS DRAWN MARKED BM46

SHOP MATERIAL LIST FOR 1 ASSEMBLY

Mark	Size	Grade	No.	Length (mm)	Area (m ²)	Weight (kg)
BM43	UB305*102*28	S275	1	2924	2.968	81.2
p33	PL10*280	S275	1	2824	1.644	62.1
p66	FLT10*140	S275	2	290	0.180	6.4
				Total	4.792	149.7

GENERAL NOTES

All Holes to be **22** Dia UNO Slot hole length is to outside
 All Welds to be **6** FW. UNO

All Steelwork Manufactured to:
 BS EN 1090-2: Execution Class **EXC2** U.N.O.

FINISH **GALVANISED**

LOT **0** QTY **1**
 PHASE **1** QTY **1**

FABRICATION STATUS

Sawn by: _____ Date: _____
 Fabricated by: _____ Date: _____
 Welded by: _____ Date: _____
 Loaded by: _____ Date: _____
 Checked by: _____ Date: _____

B	ISSUED FOR APPROVAL	PCS	01.02.2023	SK	01.02.2023
A	ISSUED FOR APPROVAL	PCS	25.01.2023	SK	25.01.2023
REV		By	Date	By	Date
MARK	DESCRIPTION	CREATED	CHECKED		

CLIENT: _____ **DATE CREATED:** 23.01.2023

PROJECT: Ebenezer Street **DRAWN BY:** PCS

CONTRACT NO: T8298 **DRAWING NO:** [BM.46] **REV:** B

ASSEMBLY / SUB ASSEMBLY STATUS	
1	THIS IS IT'S OWN ASSEMBLY

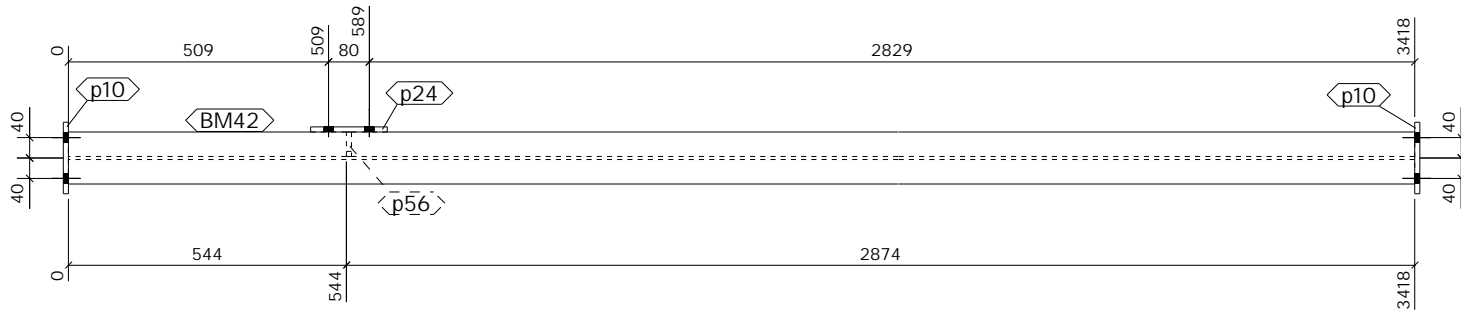

TOP VIEW
1:10

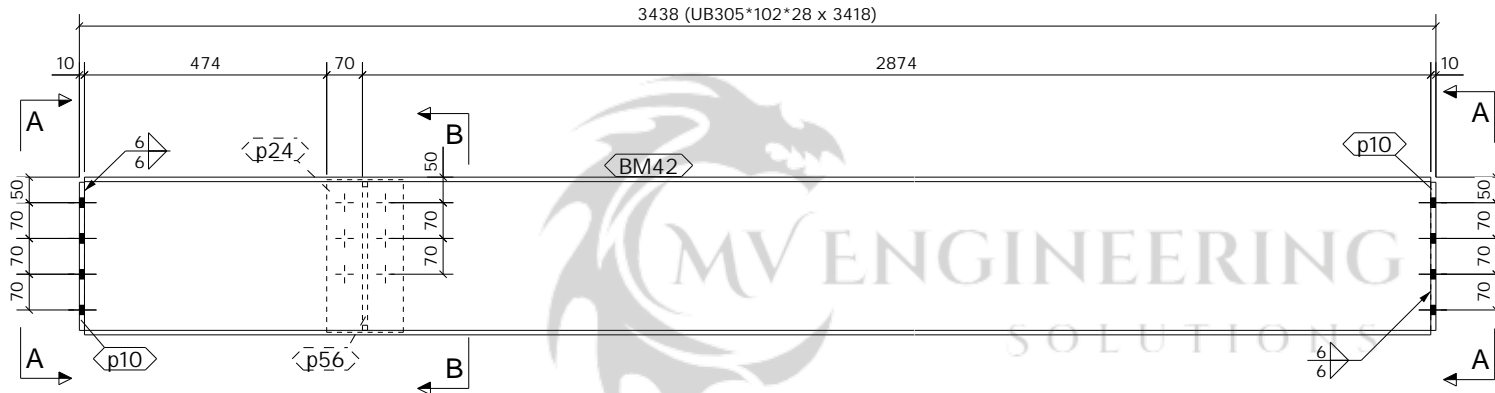

FRONT VIEW
1:10

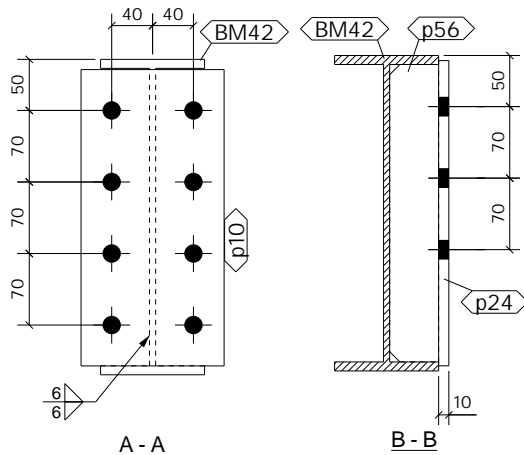

A - A

B - B

1 No. BEAM

REQUIRED AS DRAWN MARKED BM47

SHOP MATERIAL LIST FOR 1 ASSEMBLY

Mark	Size	Grade	No.	Length (mm)	Area (m ²)	Weight (kg)
BM42	UB305*102*28	S275	1	3418	3.468	94.9
p10	FLT10*140	S275	2	290	0.180	6.4
p24	FLT10*150	S275	1	299	0.099	3.5
p56	PLT10*47.9	S275	1	291	0.034	1.1
Total					3.781	105.9

GENERAL NOTES

All Holes to be **22** Dia UNO Slot hole length is to outside
 All Welds to be **6** FW. UNO

All Steelwork Manufactured to:
 BS EN 1090-2: Execution Class **EXC2** U.N.O.

FINISH **S.B. & PRIME**
 LOT **0** QTY **1**
 PHASE **1** QTY **1**

FABRICATION STATUS

Sawn by: _____ Date: _____
 Fabricated by: _____ Date: _____
 Welded by: _____ Date: _____
 Loaded by: _____ Date: _____
 Checked by: _____ Date: _____

REV	DESCRIPTION	ISSUED FOR APPROVAL			
		By	Date	By	Date
A		PCS	25.01.2023	SK	25.01.2023
MARK		CREATED		CHECKED	

CLIENT: _____ DATE CREATED: 23.01.2023

PROJECT: Ebenezer Street DRAWN BY: PCS

CONTRACT NO: T8298 DRAWING NO: [BM.47] REV: A

ASSEMBLY / SUB ASSEMBLY STATUS	
1	THIS IS IT'S OWN ASSEMBLY

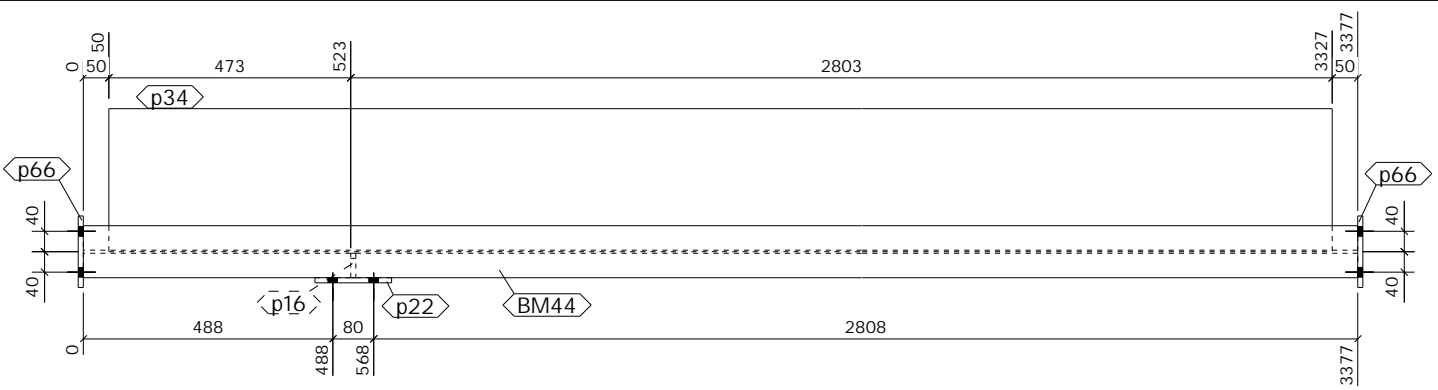

TOP VIEW
1:10

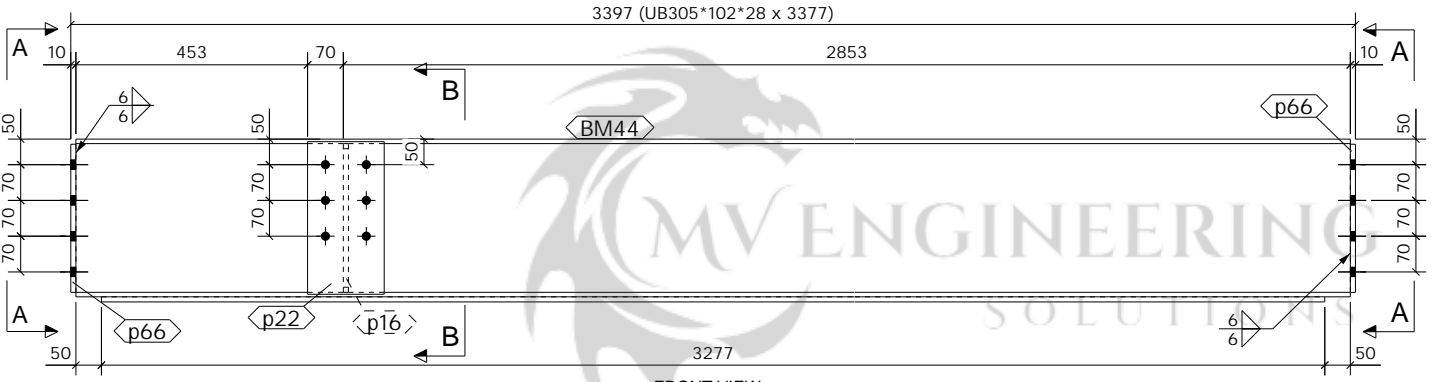

FRONT VIEW
1:10

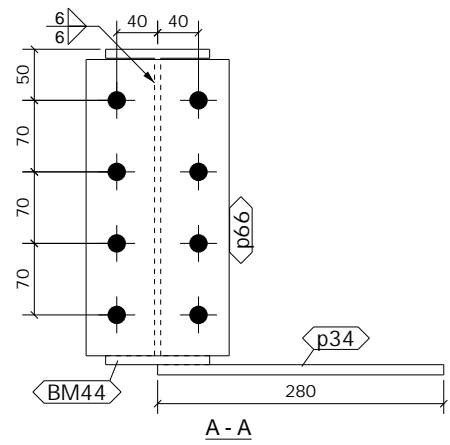

A - A

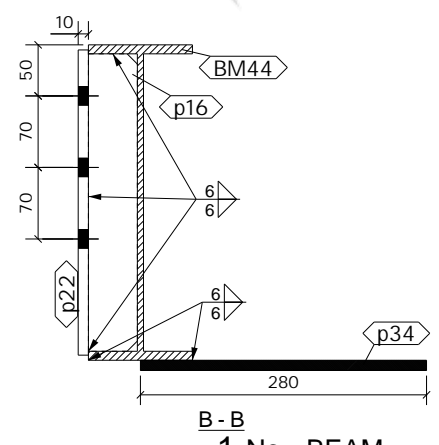

B - B

1 No. BEAM

REQUIRED AS DRAWN MARKED BM48

SHOP MATERIAL LIST FOR 1 ASSEMBLY

Mark	Size	Grade	No.	Length (mm)	Area (m ²)	Weight (kg)
BM44	UB305*102*28	S275	1	3377	3.426	93.8
p16	PLT10*47.9	S275	1	291	0.034	1.1
p22	FLT10*150	S275	1	299	0.099	3.5
p34	PL10*280	S275	1	3277	1.906	72.0
p66	FLT10*140	S275	2	290	0.180	6.4
Total					5.645	176.8

GENERAL NOTES

All Holes to be 22 Dia UNO Slot hole length is to outside
 All Welds to be 6 FW. UNO

All Steelwork Manufactured to:
 BS EN 1090-2: Execution Class **EXC2** U.N.O.

FINISH **GALVANISED**

LOT 0 QTY 1
 PHASE 1 QTY 1

FABRICATION STATUS

Sawn by: _____ Date: _____
 Fabricated by: _____ Date: _____
 Welded by: _____ Date: _____
 Loaded by: _____ Date: _____
 Checked by: _____ Date: _____

REV	DESCRIPTION	By	Date	By	Date
B	ISSUED FOR APPROVAL	PCS	01.02.2023	SK	01.02.2023
A	ISSUED FOR APPROVAL	PCS	25.01.2023	SK	25.01.2023
MARK	DESCRIPTION	CREATED	CHECKED		

CLIENT: _____ DATE CREATED: 23.01.2023

PROJECT: Ebenezer Street DRAWN BY: PCS

CONTRACT NO: T8298 DRAWING NO: [BM.48] REV: B

ASSEMBLY / SUB ASSEMBLY STATUS	
1	THIS IS IT'S OWN ASSEMBLY

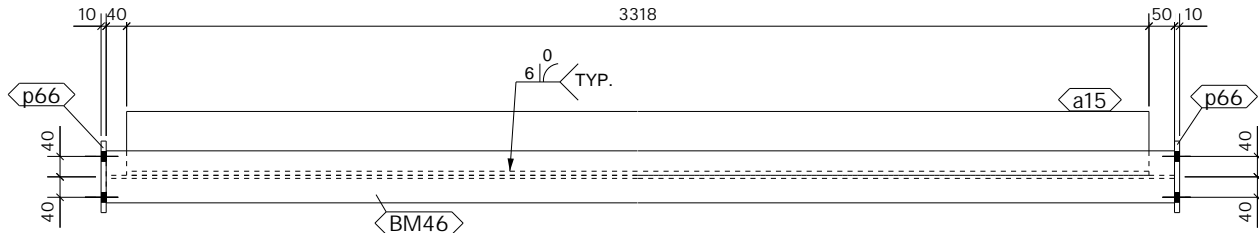

TOP VIEW
1:10

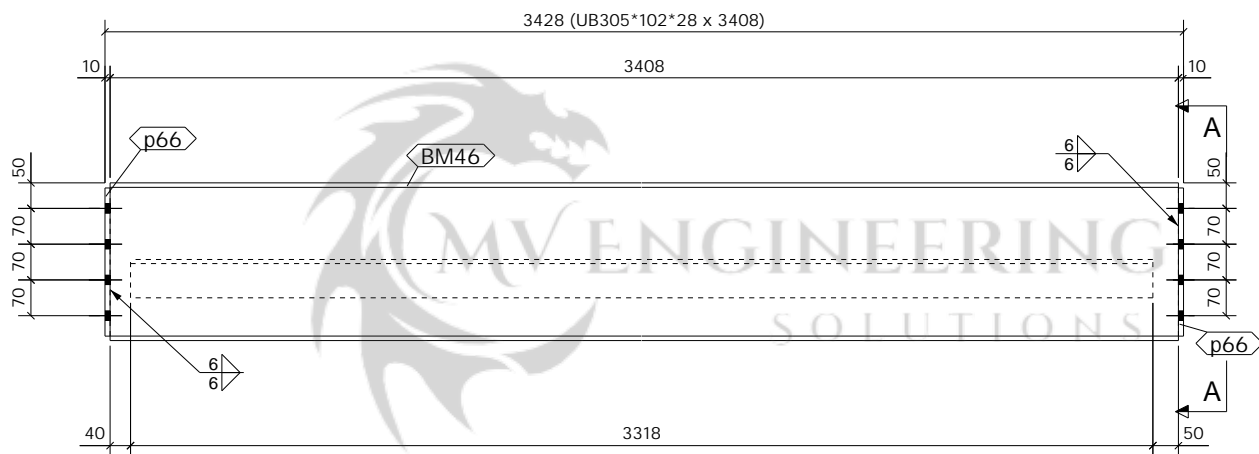

FRONT VIEW
1:10

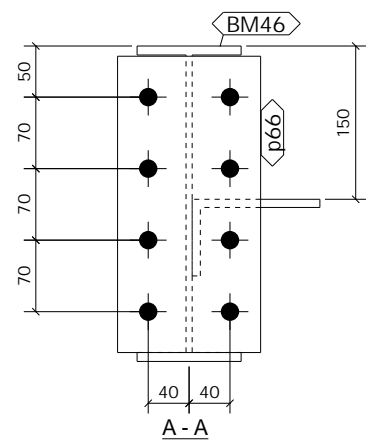

1 No. BEAM

REQUIRED AS DRAWN MARKED BM49

SHOP MATERIAL LIST FOR 1 ASSEMBLY

Mark	Size	Grade	No.	Length (mm)	Area (m ²)	Weight (kg)
BM46	UB305*102*28	S275	1	3408	3.458	94.7
a15	RSA125*75*8	S275	1	3318	1.330	40.0
p66	FLT10*140	S275	2	290	0.180	6.4
Total					4.968	141.0

GENERAL NOTES

All Holes to be 22 Dia UNO Slot hole length is to outside
 All Welds to be 6 FW. UNO

All Steelwork Manufactured to:
 BS EN 1090-2: Execution Class EXC2 U.N.O.

FINISH GALVANISED
 LOT 0 QTY 1
 PHASE 1 QTY 1

FABRICATION STATUS

Sawn by: _____ Date: _____
 Fabricated by: _____ Date: _____
 Welded by: _____ Date: _____
 Loaded by: _____ Date: _____
 Checked by: _____ Date: _____

REV	DESCRIPTION	By	Date	By	Date
A	ISSUED FOR APPROVAL	PCS	25.01.2023	SK	25.01.2023
MARK	DESCRIPTION	CREATED		CHECKED	

CLIENT: Ebenezzer Street DATE CREATED: 23.01.2023

PROJECT: Ebenezzer Street DRAWN BY: PCS

CONTRACT NO: T8298 DRAWING NO: [BM.49] REV: A

ASSEMBLY / SUB ASSEMBLY STATUS	
1	THIS IS IT'S OWN ASSEMBLY

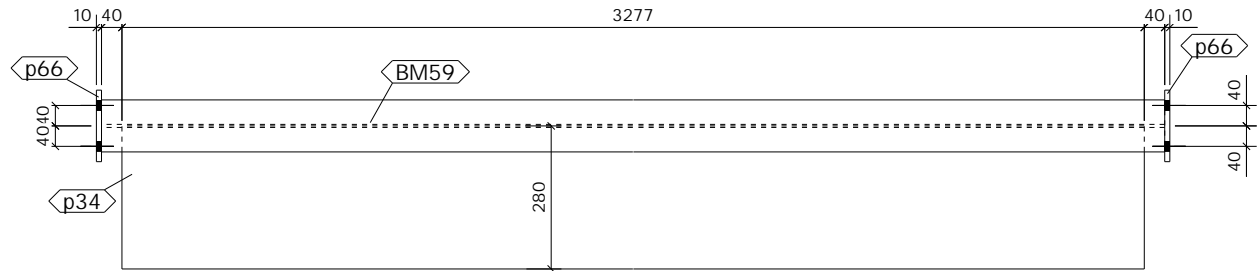

TOP VIEW
1:10

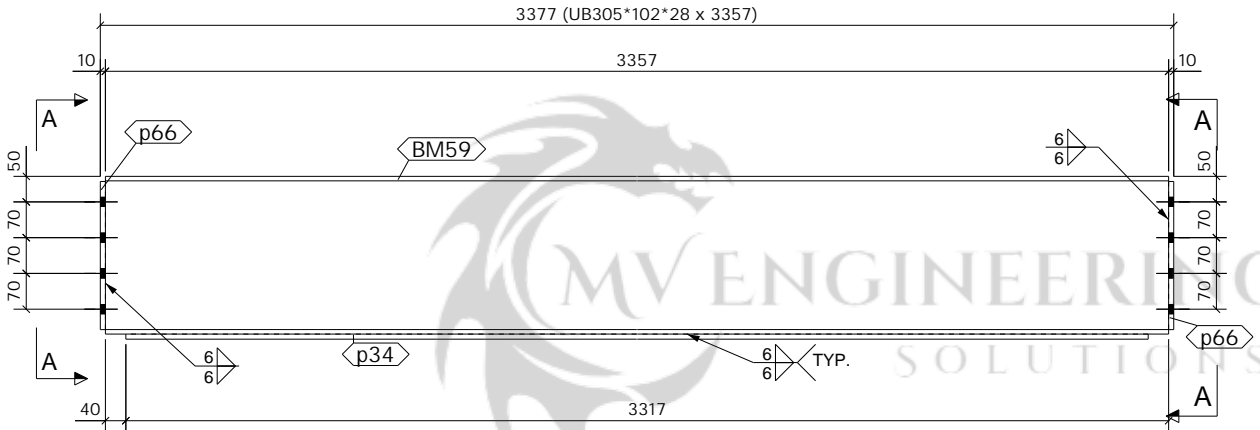

FRONT VIEW
1:10

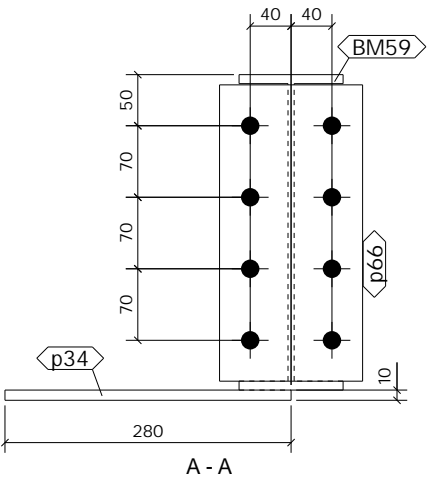

A - A

1 No. BEAM

REQUIRED AS DRAWN MARKED BM50

SHOP MATERIAL LIST FOR 1 ASSEMBLY

Mark	Size	Grade	No.	Length (mm)	Area (m ²)	Weight (kg)
BM59	UB305*102*28	S275	1	3357	3.406	93.2
p34	PL10*280	S275	1	3277	1.906	72.0
p66	FLT10*140	S275	2	290	0.180	6.4
				Total	5.492	171.6

GENERAL NOTES

All Holes to be 22 Dia UNO Slot hole length is to outside
 All Welds to be 6 FW. UNO

All Steelwork Manufactured to:
 BS EN 1090-2: Execution Class **EXC2** U.N.O.

FINISH **GALVANISED**
 LOT **0** QTY **1**
 PHASE **1** QTY **1**

FABRICATION STATUS

Sawn by: _____ Date: _____
 Fabricated by: _____ Date: _____
 Welded by: _____ Date: _____
 Loaded by: _____ Date: _____
 Checked by: _____ Date: _____

B	ISSUED FOR APPROVAL	PCS	01.02.2023	SK	01.02.2023
A	ISSUED FOR APPROVAL	PCS	25.01.2023	SK	25.01.2023
REV		By	Date	By	Date
MARK	DESCRIPTION	CREATED	CHECKED		

CLIENT: _____ DATE CREATED: 23.01.2023

PROJECT: Ebenezer Street DRAWN BY: PCS

CONTRACT NO: T8298 DRAWING NO: [BM.50] REV: B

ASSEMBLY / SUB ASSEMBLY STATUS	
1	THIS IS IT'S OWN ASSEMBLY

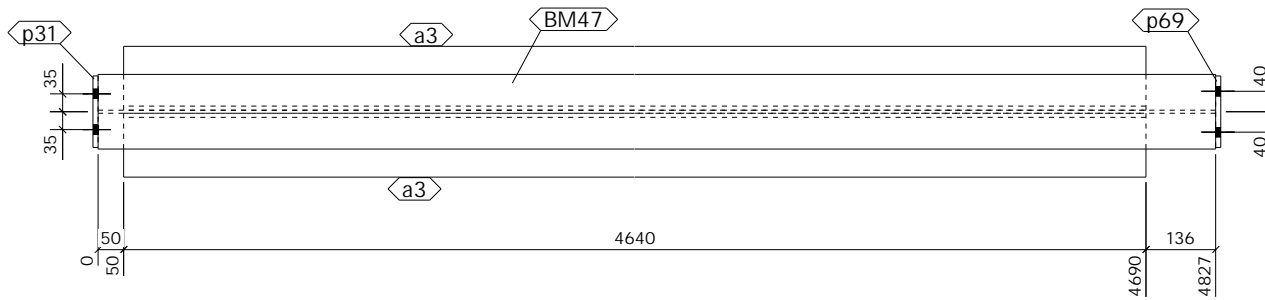

TOP VIEW
1:10

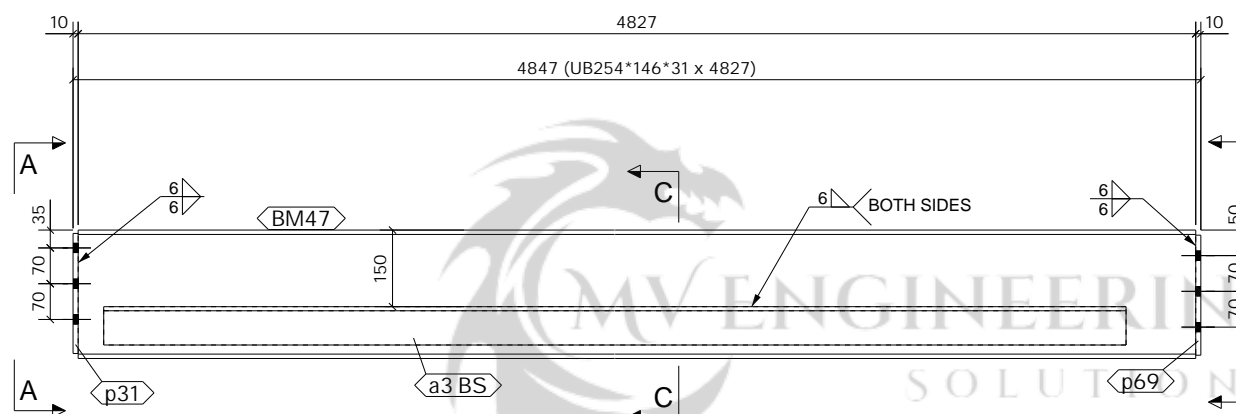

FRONT VIEW
1:10

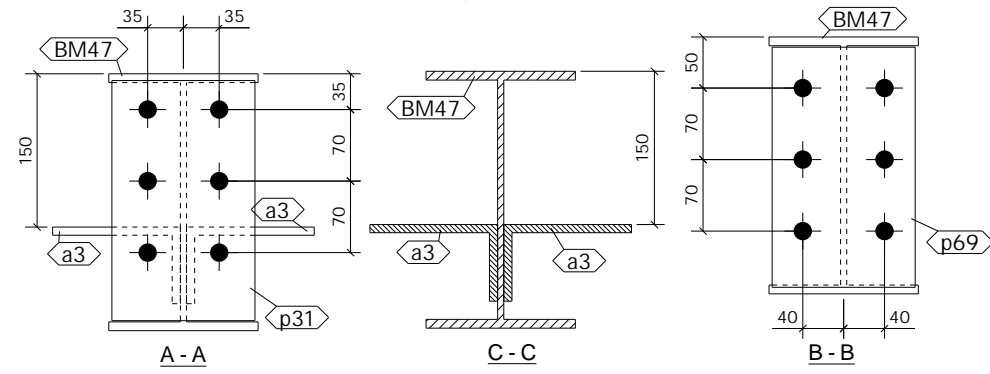

1 No. BEAM

REQUIRED AS DRAWN MARKED BM51

SHOP MATERIAL LIST FOR 1 ASSEMBLY

Mark	Size	Grade	No.	Length (mm)	Area (m ²)	Weight (kg)
BM47	UB254*146*31	S275	1	4827	5.198	148.5
a3	RSA125*75*8	S275	2	4640	3.718	111.9
p31	FLT10*140	S275	1	235	0.073	2.6
p69	FLT10*140	S275	1	235	0.073	2.6
Total					9.062	265.5

GENERAL NOTES

All Holes to be 22 Dia UNO Slot hole length is to outside
 All Welds to be 6 FW. UNO

All Steelwork Manufactured to:
 BS EN 1090-2: Execution Class EXC2 U.N.O.

FINISH GALVANISED
 LOT 0 QTY 1
 PHASE 1 QTY 1

FABRICATION STATUS

Sawn by: _____ Date: _____
 Fabricated by: _____ Date: _____
 Welded by: _____ Date: _____
 Loaded by: _____ Date: _____
 Checked by: _____ Date: _____

REV	DESCRIPTION	ISSUED FOR APPROVAL			
		By	Date	By	Date
A		PCS	25.01.2023	SK	25.01.2023
MARK		CREATED		CHECKED	

CLIENT: _____ DATE CREATED: 23.01.2023

PROJECT: Ebenezer Street DRAWN BY: PCS

CONTRACT NO: T8298 DRAWING NO: [BM.51] REV: A

ASSEMBLY / SUB ASSEMBLY STATUS	
1	THIS IS IT'S OWN ASSEMBLY



TOP VIEW
1:10

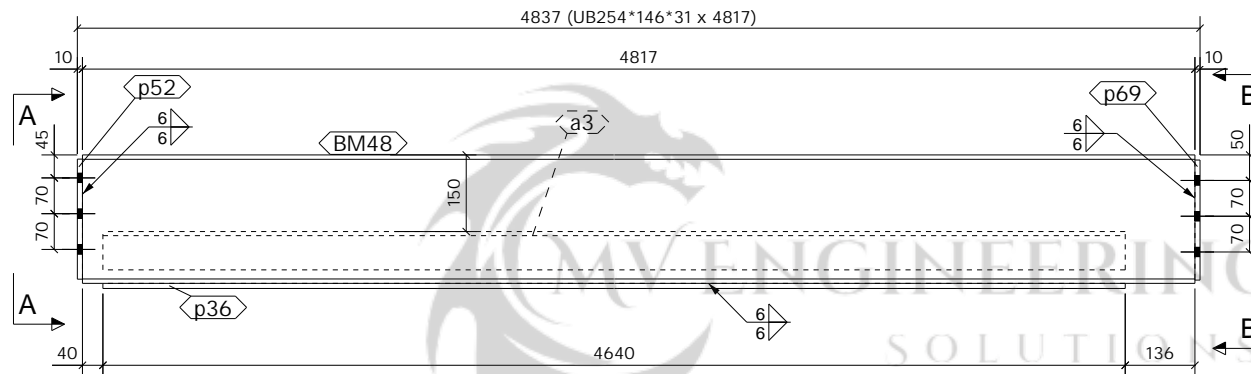

FRONT VIEW
1:10

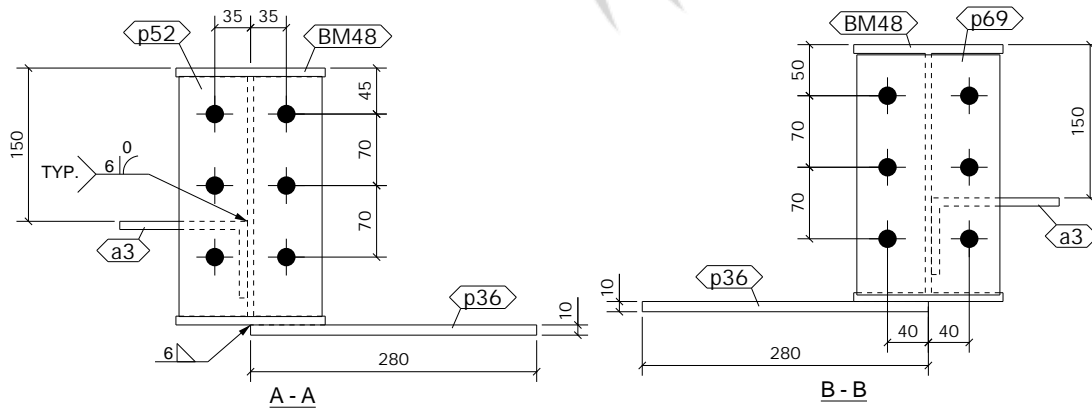

A - A

B - B

1 No. BEAM

REQUIRED AS DRAWN MARKED BM52

SHOP MATERIAL LIST FOR 1 ASSEMBLY

Mark	Size	Grade	No.	Length (mm)	Area (m ²)	Weight (kg)
BM48	UB254*146*31	S275	1	4817	5.187	148.1
a3	RSA125*75*8	S275	1	4640	1.859	56.0
p36	PL10*280	S275	1	4640	2.697	102.0
p52	FLT10*140	S275	1	235	0.073	2.6
p69	FLT10*140	S275	1	235	0.073	2.6
Total					9.890	311.3

GENERAL NOTES

All Holes to be 22 Dia UNO Slot hole length is to outside
All Welds to be 6 FW. UNO

All Steelwork Manufactured to:
BS EN 1090-2: Execution Class **EXC2** U.N.O.

FINISH **GALVANISED**

LOT **0** QTY **1**

PHASE **1** QTY **1**

FABRICATION STATUS

Sawn by: _____ Date: _____
Fabricated by: _____ Date: _____
Welded by: _____ Date: _____
Loaded by: _____ Date: _____
Checked by: _____ Date: _____

A	ISSUED FOR APPROVAL	PC		SK	
		By	Date	By	Date
		PCS	25.01.2023	SK	25.01.2023
REV	DESCRIPTION	CREATED	CHECKED		

CLIENT: _____ DATE CREATED: 23.01.2023

PROJECT: Ebenezer Street DRAWN BY: PCS

CONTRACT NO: T8298 DRAWING NO: [BM.52] REV: A

ASSEMBLY / SUB ASSEMBLY STATUS	
1	THIS IS IT'S OWN ASSEMBLY

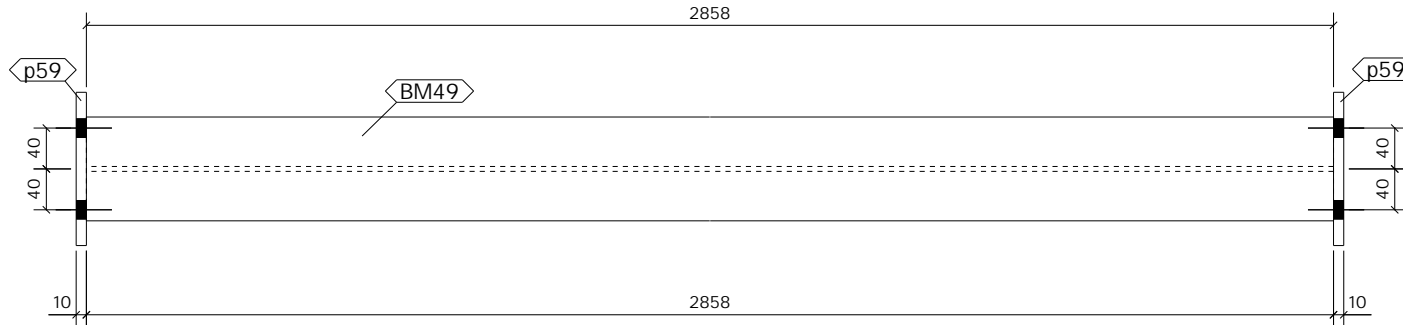

TOP VIEW
1:5

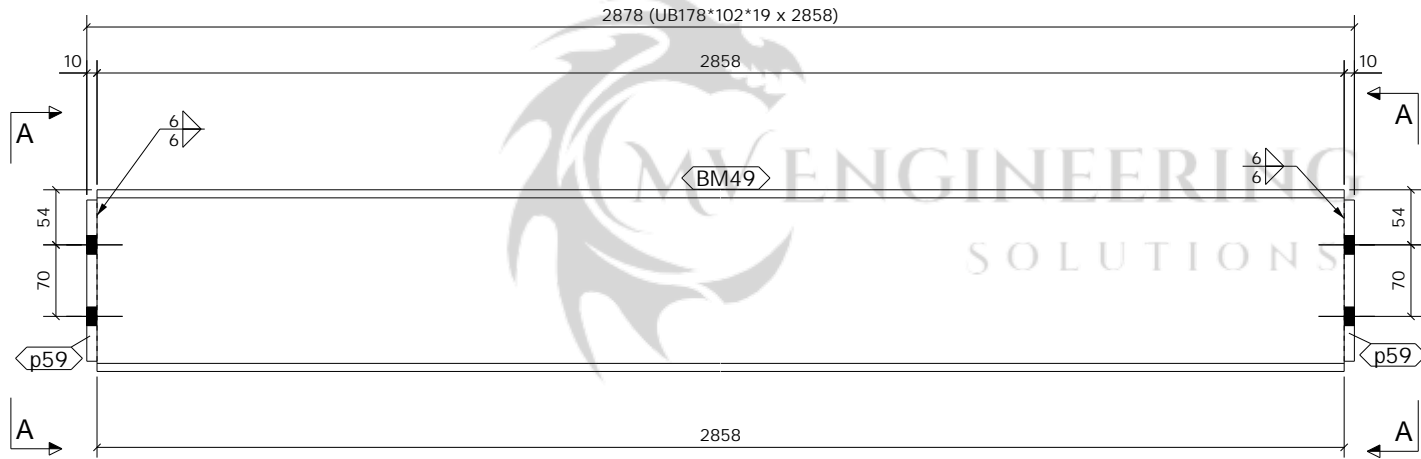

FRONT VIEW
1:5

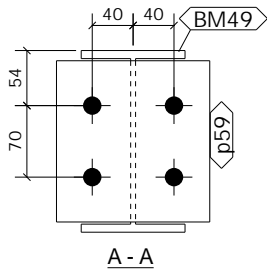

A - A

1 No. BEAM

REQUIRED AS DRAWN MARKED BM53

SHOP MATERIAL LIST FOR 1 ASSEMBLY

Mark	Size	Grade	No.	Length (mm)	Area (m ²)	Weight (kg)
BM49	UB178*102*19	S275	1	2858	2.155	53.5
p59	FLT10*150	S275	2	158	0.107	3.7
Total					2.262	57.2

GENERAL NOTES

All Holes to be 22 Dia UNO Slot hole length is to outside
 All Welds to be 6 FW. UNO

All Steelwork Manufactured to:
 BS EN 1090-2: Execution Class EXC2 U.N.O.

FINISH **S.B. & PRIME**
 LOT 0 QTY 1
 PHASE 1 QTY 1

FABRICATION STATUS

Sawn by: _____ Date: _____
 Fabricated by: _____ Date: _____
 Welded by: _____ Date: _____
 Loaded by: _____ Date: _____
 Checked by: _____ Date: _____

REV	DESCRIPTION	ISSUED FOR APPROVAL			
		By	Date	By	Date
A		PCS	25.01.2023	SK	25.01.2023
MARK		CREATED		CHECKED	

CLIENT: _____ DATE CREATED: 23.01.2023

PROJECT: Ebenezer Street DRAWN BY: PCS

CONTRACT NO: T8298 DRAWING NO: [BM.53] REV: A

ASSEMBLY / SUB ASSEMBLY STATUS	
1	THIS IS IT'S OWN ASSEMBLY

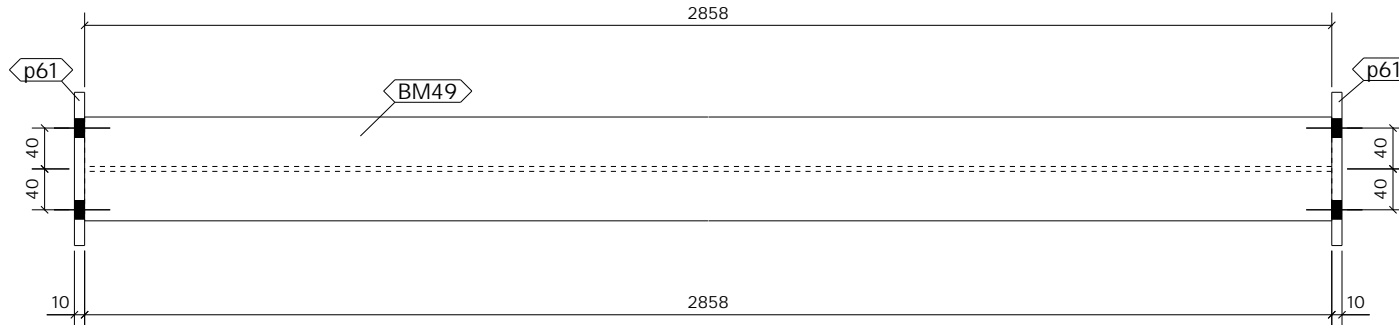

TOP VIEW
1:5

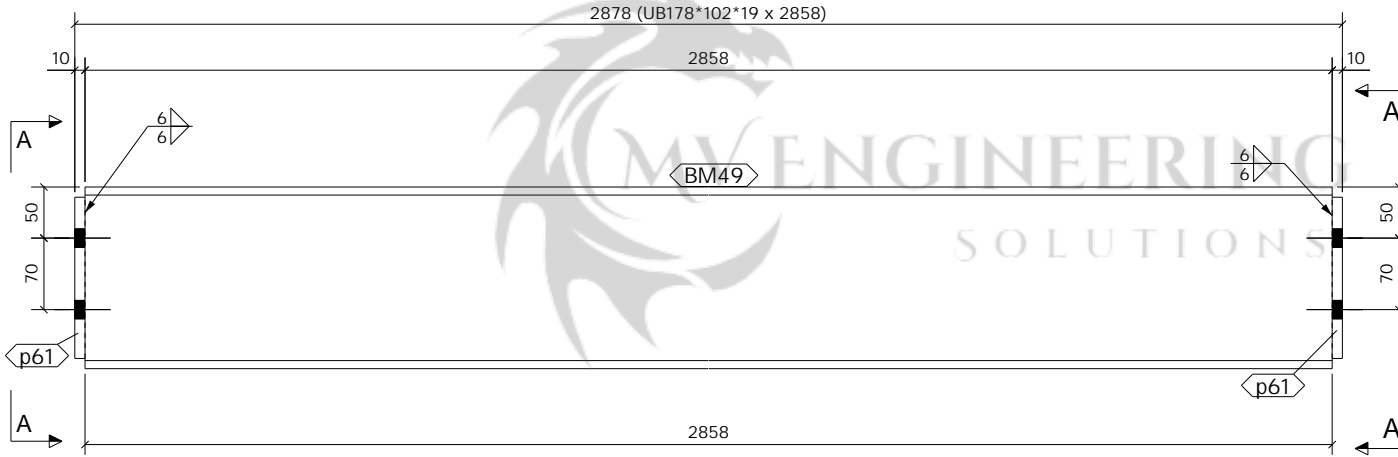

FRONT VIEW
1:5

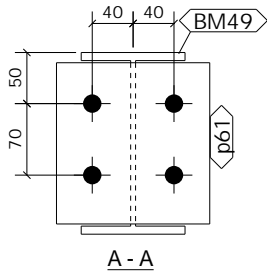

A - A

1 No. BEAM

REQUIRED AS DRAWN MARKED BM54

SHOP MATERIAL LIST FOR 1 ASSEMBLY

Mark	Size	Grade	No.	Length (mm)	Area (m ²)	Weight (kg)
BM49	UB178*102*19	S275	1	2858	2.155	53.5
p61	FLT10*150	S275	2	158	0.107	3.7
Total					2.262	57.2

GENERAL NOTES

All Holes to be 22 Dia UNO Slot hole length is to outside
All Welds to be 6 FW. UNO

All Steelwork Manufactured to:
BS EN 1090-2: Execution Class EXC2 U.N.O.

FINISH **S.B. & PRIME**
LOT **0** QTY **1**
PHASE **1** QTY **1**

FABRICATION STATUS

Sawn by: _____ Date: _____
Fabricated by: _____ Date: _____
Welded by: _____ Date: _____
Loaded by: _____ Date: _____
Checked by: _____ Date: _____

REV	DESCRIPTION	ISSUED FOR APPROVAL			
		By	Date	By	Date
A		PCS	25.01.2023	SK	25.01.2023
MARK		CREATED		CHECKED	

CLIENT: _____ DATE CREATED: 23.01.2023

PROJECT: Ebenezer Street DRAWN BY: PCS

CONTRACT NO: T8298 DRAWING NO: [BM.54] REV: A

ASSEMBLY / SUB ASSEMBLY STATUS	
1	THIS IS IT'S OWN ASSEMBLY

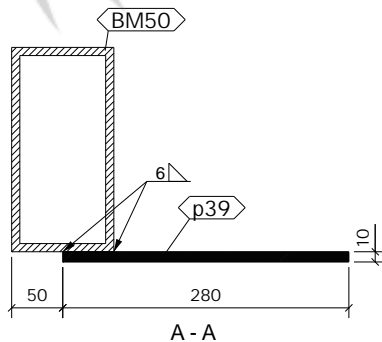
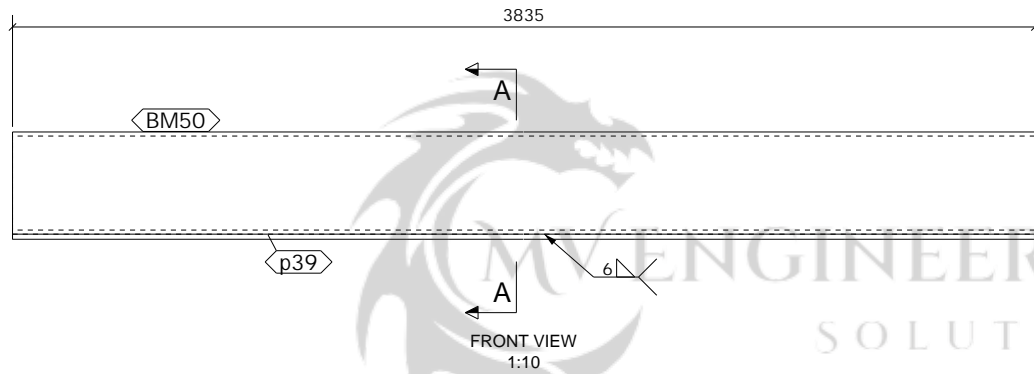
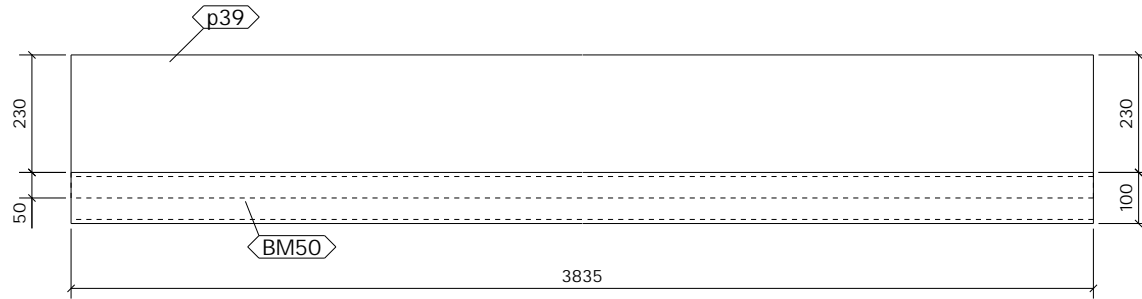

SHOP MATERIAL LIST FOR 1 ASSEMBLY

Mark	Size	Grade	No.	Length (mm)	Area (m ²)	Weight (kg)
BM50	RHS200*100*8.0	S275	1	3835	2.274	136.8
p39	PL10*280	S275	1	3835	2.230	84.3
Total					4.504	221.1

GENERAL NOTES

All Holes to be **22** Dia UNO Slot hole length is to outside
 All Welds to be **6** FW. UNO

All Steelwork Manufactured to:
 BS EN 1090-2: Execution Class **EXC2** U.N.O.

FINISH **S.B. & PRIME**
 LOT **0** QTY **1**
 PHASE **1** QTY **1**

FABRICATION STATUS

Sawn by: _____ Date: _____
 Fabricated by: _____ Date: _____
 Welded by: _____ Date: _____
 Loaded by: _____ Date: _____
 Checked by: _____ Date: _____

A	ISSUED FOR APPROVAL	CREATED		CHECKED	
		By	Date	By	Date
		PCS	25.01.2023	SK	25.01.2023
REV	DESCRIPTION	CREATED	CHECKED		

CLIENT: Ebenezer Street **DATE CREATED:** 23.01.2023

PROJECT: Ebenezer Street **DRAWN BY:** PCS

CONTRACT NO: T8298 **DRAWING NO:** [BM.55] **REV:** A

1 No. BEAM

REQUIRED AS DRAWN MARKED BM55

ASSEMBLY / SUB ASSEMBLY STATUS	
1	THIS IS IT'S OWN ASSEMBLY

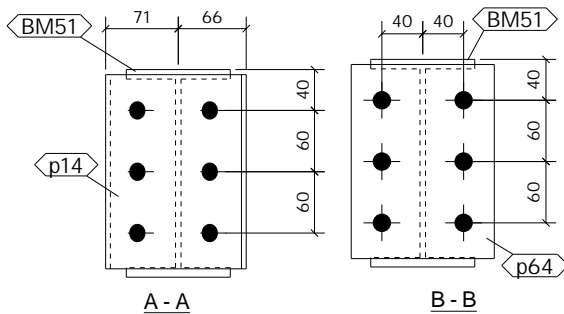
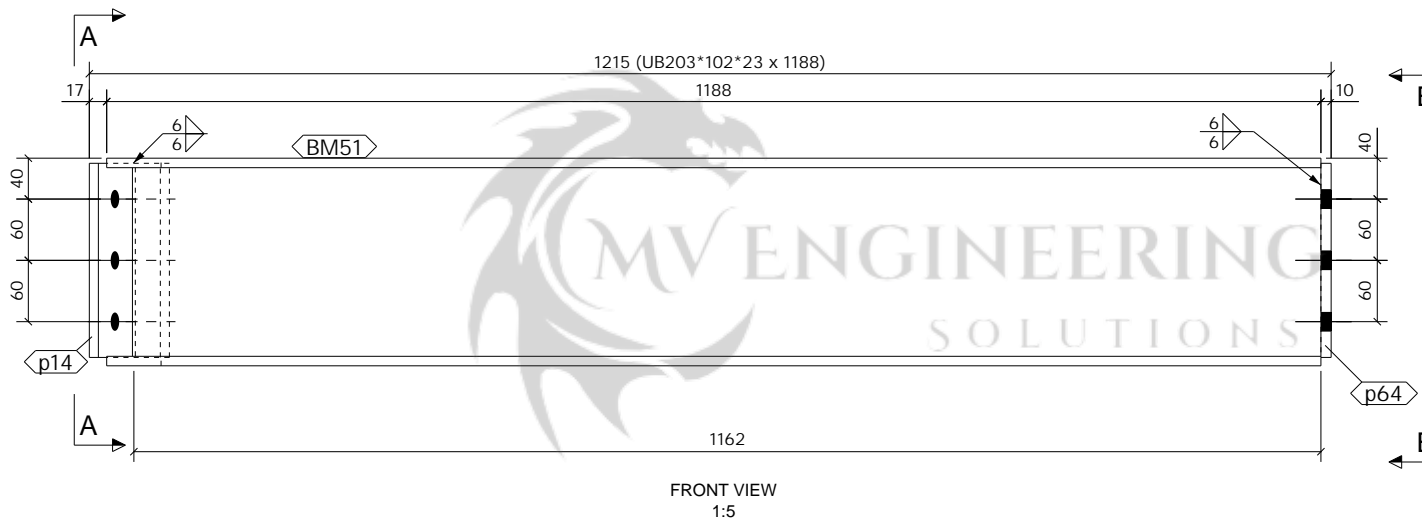
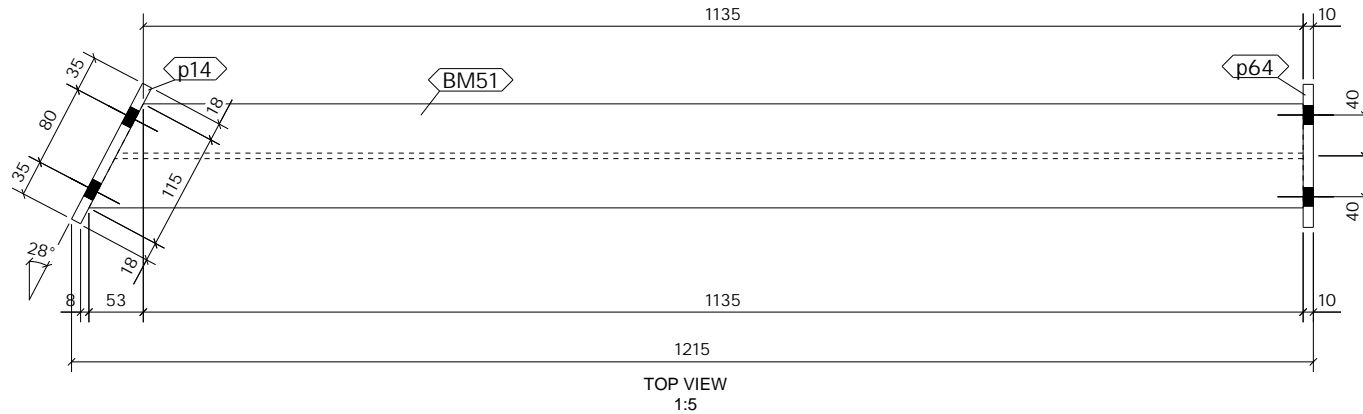

1 No. BEAM

REQUIRED AS DRAWN MARKED BM56

ASSEMBLY / SUB ASSEMBLY STATUS	
1	THIS IS IT'S OWN ASSEMBLY

SHOP MATERIAL LIST FOR 1 ASSEMBLY

Mark	Size	Grade	No.	Length (mm)	Area (m ²)	Weight (kg)
BM51	UB203*102*23	S275	1	1188	0.939	26.4
p14	FLT10*150	S275	1	190	0.064	2.2
p64	FLT10*140	S275	1	190	0.060	2.1
				Total	1.062	30.7

GENERAL NOTES

All Holes to be **22** Dia UNO Slot hole length is to outside
 All Welds to be **6** FW. UNO

All Steelwork Manufactured to:
 BS EN 1090-2: Execution Class **EXC2** U.N.O.

FINISH **GALVANISED**
 LOT **0** QTY **1**
 PHASE **1** QTY **1**

FABRICATION STATUS

Sawn by: _____ Date: _____
 Fabricated by: _____ Date: _____
 Welded by: _____ Date: _____
 Loaded by: _____ Date: _____
 Checked by: _____ Date: _____

A	ISSUED FOR APPROVAL	PCS		SK	
		By	Date	By	Date
			25.01.2023		25.01.2023
REV	DESCRIPTION	CREATED	CHECKED		

CLIENT: **DATE CREATED:**
 Ebenezer Street 23.01.2023

PROJECT: **DRAWN BY:**
 Ebenezer Street PCS

CONTRACT NO: **DRAWING NO:** **REV:**
 T8298 [BM.56] A

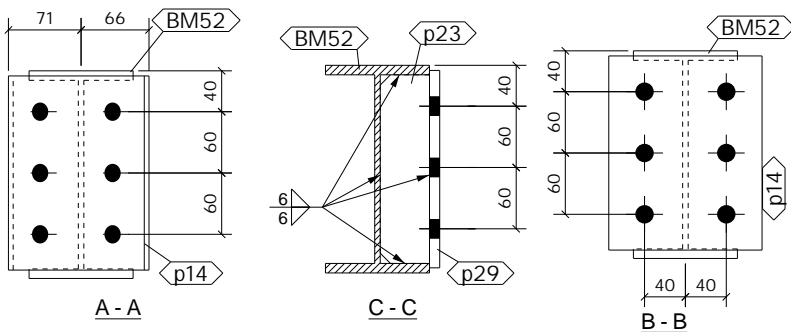
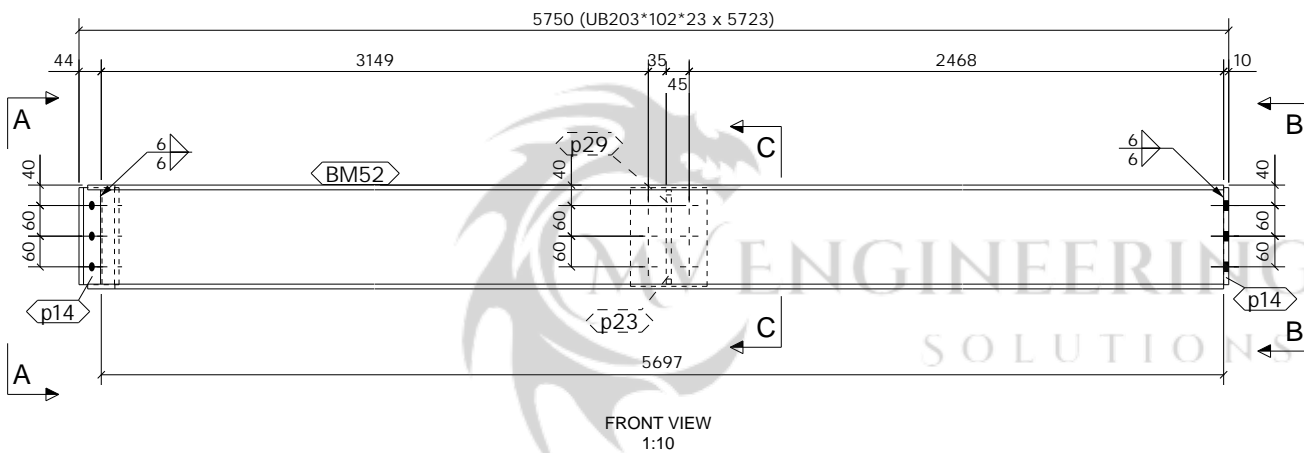
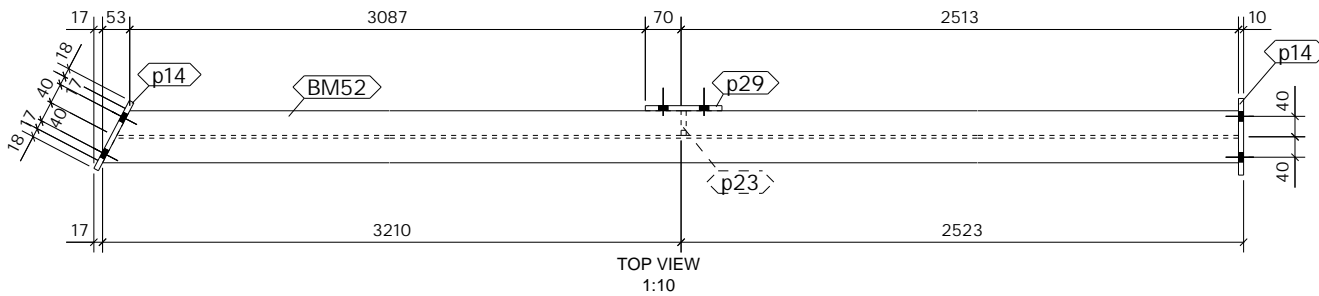

1 No. BEAM

REQUIRED AS DRAWN MARKED BM57

SHOP MATERIAL LIST FOR 1 ASSEMBLY

Mark	Size	Grade	No.	Length (mm)	Area (m ²)	Weight (kg)
BM52	UB203*102*23	S275	1	5723	4.579	129.2
p14	FLT10*150	S275	2	190	0.128	4.5
p23	PLT10*48.2	S275	1	185	0.022	0.7
p29	FLT10*150	S275	1	193	0.065	2.3
Total					4.794	136.7

GENERAL NOTES

All Holes to be 22 Dia UNO Slot hole length is to outside
 All Welds to be 6 FW. UNO

All Steelwork Manufactured to:
 BS EN 1090-2: Execution Class **EXC2** U.N.O.

FINISH **GALVANISED**
 LOT 0 QTY 1
 PHASE 1 QTY 1

FABRICATION STATUS

Sawn by: _____ Date: _____
 Fabricated by: _____ Date: _____
 Welded by: _____ Date: _____
 Loaded by: _____ Date: _____
 Checked by: _____ Date: _____

REV	MARK	DESCRIPTION	ISSUED FOR APPROVAL			
			By	Date	By	Date
A			PCS	25.01.2023	SK	25.01.2023
			CREATED		CHECKED	

CLIENT: Ebenezzer Street

DATE CREATED: 23.01.2023

PROJECT: Ebenezzer Street

DRAWN BY: PCS

CONTRACT NO: T8298

DRAWING NO: [BM.57]

REV: A

ASSEMBLY / SUB ASSEMBLY STATUS	
1	THIS IS IT'S OWN ASSEMBLY

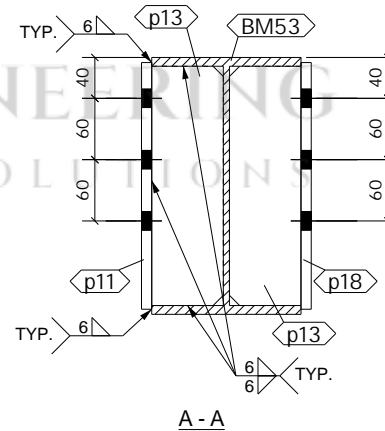
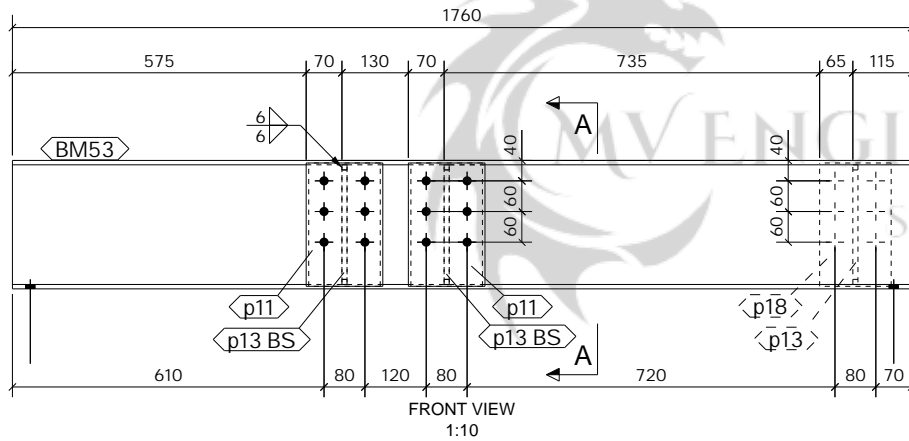
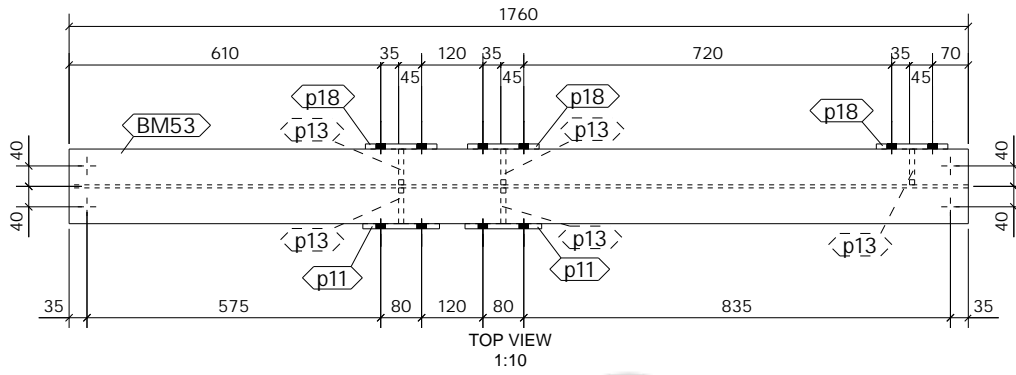

SHOP MATERIAL LIST FOR 1 ASSEMBLY

Mark	Size	Grade	No.	Length (mm)	Area (m ²)	Weight (kg)
BM53	UB254*146*31	S275	1	1760	1.900	54.1
p11	FLT10*150	S275	2	241	0.160	5.7
p13	FLT10*70	S275	5	234	0.193	6.4
p18	FLT10*140	S275	3	241	0.226	8.0
Total					2.479	74.2

GENERAL NOTES

All Holes to be **22 Dia UNO** Slot hole length is to outside
 All Welds to be **6 FW. UNO**

All Steelwork Manufactured to:
 BS EN 1090-2: Execution Class **EXC2** U.N.O.

FINISH **S.B. & PRIME**
 LOT **0** QTY **1**
 PHASE **1** QTY **1**

FABRICATION STATUS

Sawn by: _____ Date: _____
 Fabricated by: _____ Date: _____
 Welded by: _____ Date: _____
 Loaded by: _____ Date: _____
 Checked by: _____ Date: _____

A	ISSUED FOR APPROVAL	REV			
		By	Date	By	Date
		PCS	25.01.2023	SK	25.01.2023
MARK	DESCRIPTION	CREATED	CHECKED		

CLIENT: _____ **DATE CREATED:** 23.01.2023

PROJECT: Ebenezer Street **DRAWN BY:** PCS

CONTRACT NO: T8298 **DRAWING NO:** [BM.58] **REV:** A

1 No. BEAM

REQUIRED AS DRAWN MARKED **BM58**

ASSEMBLY / SUB ASSEMBLY STATUS	
1	THIS IS IT'S OWN ASSEMBLY

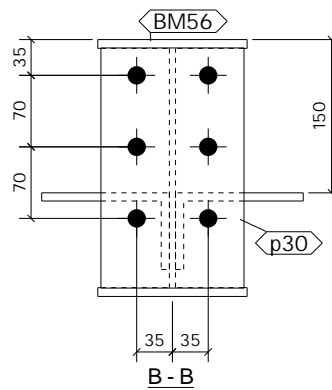
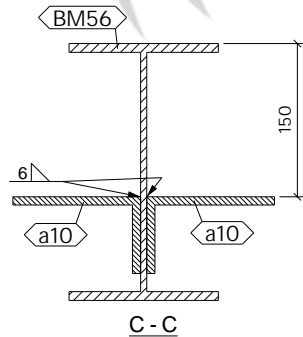
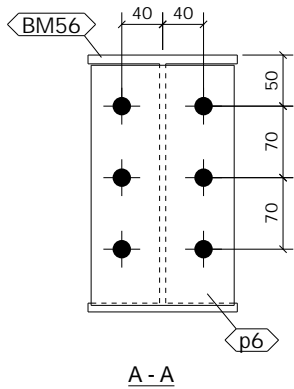
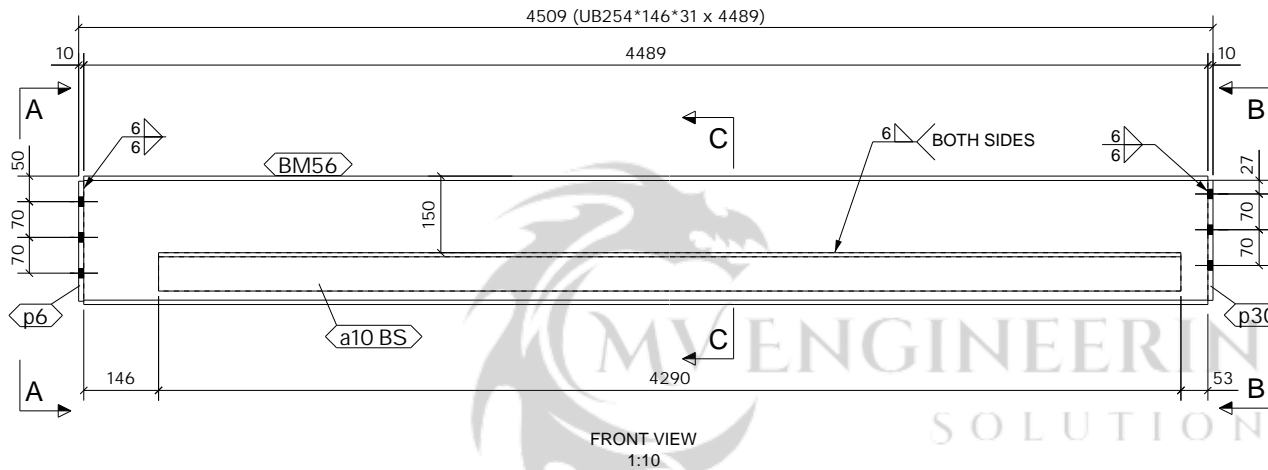
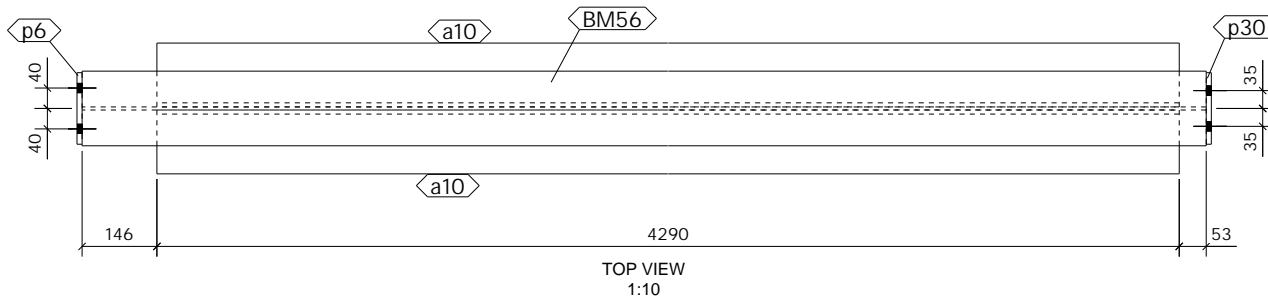

1 No. BEAM

REQUIRED AS DRAWN MARKED BM59

SHOP MATERIAL LIST FOR 1 ASSEMBLY

Mark	Size	Grade	No.	Length (mm)	Area (m ²)	Weight (kg)
BM56	UB254*146*31	S275	1	4489	4.835	138.1
a10	RSA125*75*8	S275	2	4290	3.438	103.5
p6	FLT10*140	S275	1	235	0.073	2.6
p30	FLT10*140	S275	1	235	0.073	2.6
				Total	8.419	246.7

GENERAL NOTES

All Holes to be 22 Dia UNO Slot hole length is to outside
 All Welds to be 6 FW. UNO

All Steelwork Manufactured to:
 BS EN 1090-2: Execution Class **EXC2** U.N.O.

FINISH **S.B. & PRIME**
 LOT **0** QTY **1**
 PHASE **1** QTY **1**

FABRICATION STATUS

Sawn by: _____ Date: _____
 Fabricated by: _____ Date: _____
 Welded by: _____ Date: _____
 Loaded by: _____ Date: _____
 Checked by: _____ Date: _____

REV	DESCRIPTION	ISSUED FOR APPROVAL			
		By	Date	By	Date
A		PCS	25.01.2023	SK	25.01.2023
MARK		CREATED		CHECKED	

CLIENT: _____ DATE CREATED: 23.01.2023

PROJECT: Ebenezer Street DRAWN BY: PCS

CONTRACT NO: T8298 DRAWING NO: [BM.59] REV: A

ASSEMBLY / SUB ASSEMBLY STATUS	
1	THIS IS IT'S OWN ASSEMBLY

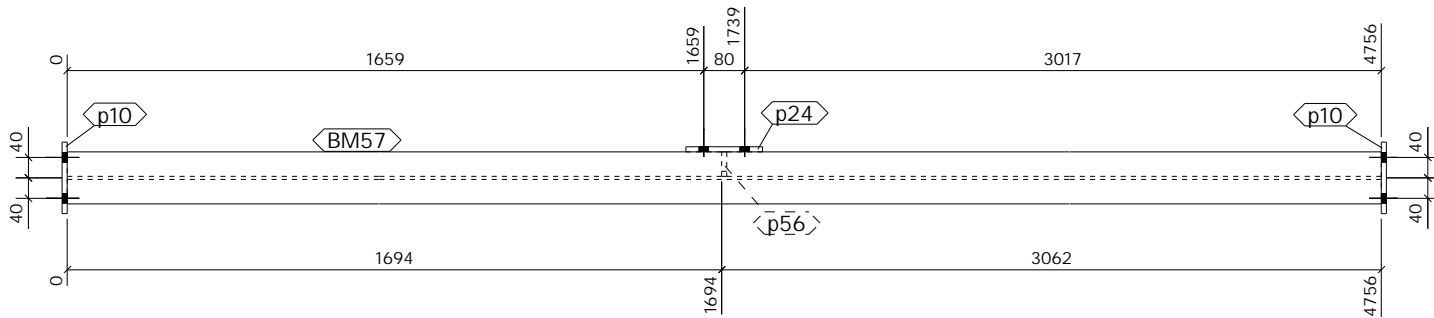

TOP VIEW
1:10

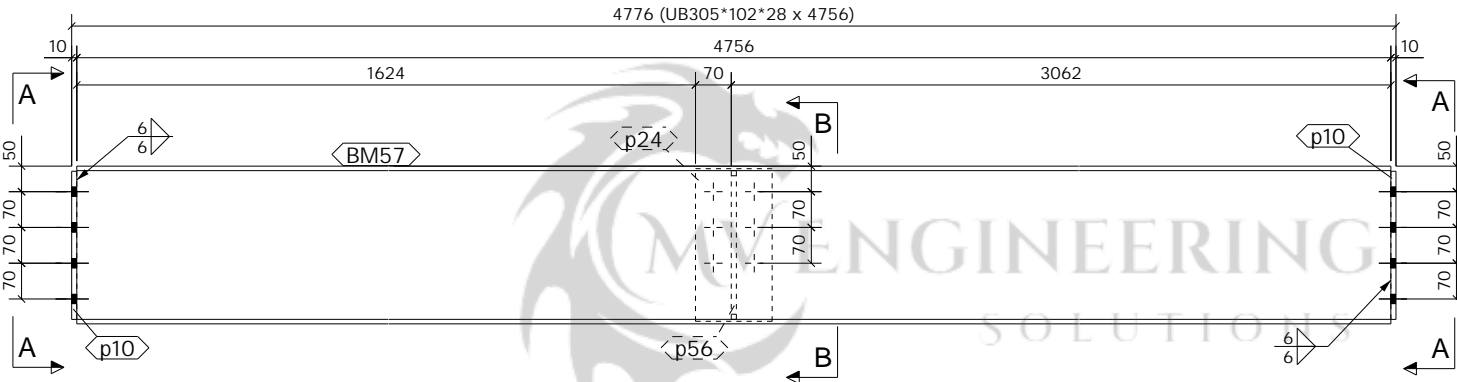

FRONT VIEW
1:10

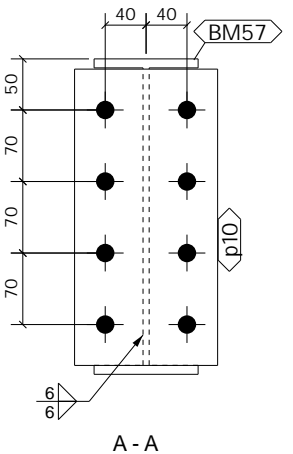

A - A

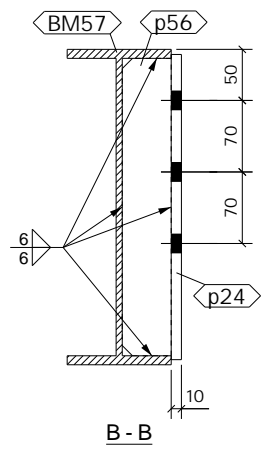

B - B

1 No. BEAM

REQUIRED AS DRAWN MARKED BM60

SHOP MATERIAL LIST FOR 1 ASSEMBLY

Mark	Size	Grade	No.	Length (mm)	Area (m ²)	Weight (kg)
BM57	UB305*102*28	S275	1	4756	4.823	132.1
p10	FLT10*140	S275	2	290	0.180	6.4
p24	FLT10*150	S275	1	299	0.099	3.5
p56	PLT10*47.9	S275	1	291	0.034	1.1
Total					5.135	143.1

GENERAL NOTES

All Holes to be 22 Dia UNO Slot hole length is to outside
 All Welds to be 6 FW. UNO

All Steelwork Manufactured to:
 BS EN 1090-2: Execution Class EXC2 U.N.O.

FINISH S.B. & PRIME
 LOT 0 QTY 1
 PHASE 1 QTY 1

FABRICATION STATUS

Sawn by: _____ Date: _____
 Fabricated by: _____ Date: _____
 Welded by: _____ Date: _____
 Loaded by: _____ Date: _____
 Checked by: _____ Date: _____

REV	DESCRIPTION	ISSUED FOR APPROVAL			
		By	Date	By	Date
A		PCS	25.01.2023	SK	25.01.2023
MARK		CREATED		CHECKED	

CLIENT: Ebenezzer Street DATE CREATED: 23.01.2023

PROJECT: Ebenezzer Street DRAWN BY: PCS

CONTRACT NO: T8298 DRAWING NO: [BM.60] REV: A

ASSEMBLY / SUB ASSEMBLY STATUS	
1	THIS IS IT'S OWN ASSEMBLY

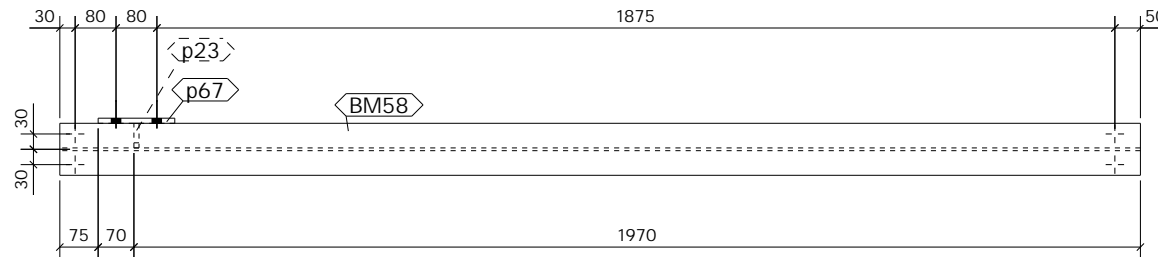

TOP VIEW
1:10

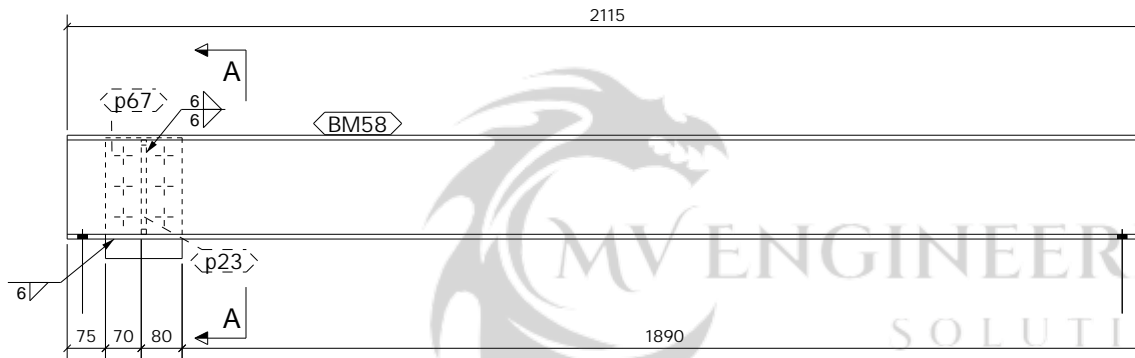

FRONT VIEW
1:10

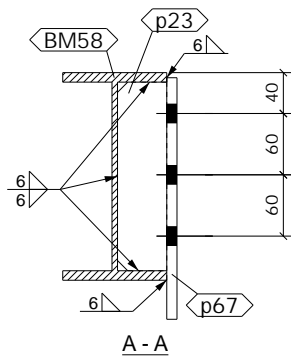

A - A

1 No. BEAM

REQUIRED AS DRAWN MARKED BM61

SHOP MATERIAL LIST FOR 1 ASSEMBLY

Mark	Size	Grade	No.	Length (mm)	Area (m ²)	Weight (kg)
BM58	UB203*102*23	S275	1	2115	1.704	48.0
p23	PLT10*48.2	S275	1	185	0.022	0.7
p67	FLT10*150	S275	1	236	0.079	2.8
Total					1.804	51.5

GENERAL NOTES

All Holes to be **22 Dia UNO** Slot hole length is to outside
 All Welds to be **6 FW. UNO**

All Steelwork Manufactured to:
 BS EN 1090-2: Execution Class **EXC2** U.N.O.

FINISH **GALVANISED**

LOT **0** QTY **1**

PHASE **1** QTY **1**

FABRICATION STATUS

Sawn by: _____ Date: _____

Fabricated by: _____ Date: _____

Welded by: _____ Date: _____

Loaded by: _____ Date: _____

Checked by: _____ Date: _____

A	ISSUED FOR APPROVAL	PC		SK	
		25.01.2023		25.01.2023	
REV		By	Date	By	Date
MARK	DESCRIPTION	CREATED		CHECKED	

CLIENT: _____ **DATE CREATED:** 23.01.2023

PROJECT: Ebenezer Street **DRAWN BY:** PCS

CONTRACT NO: T8298 **DRAWING NO:** [BM.61] **REV:** A

ASSEMBLY / SUB ASSEMBLY STATUS	
1	THIS IS IT'S OWN ASSEMBLY

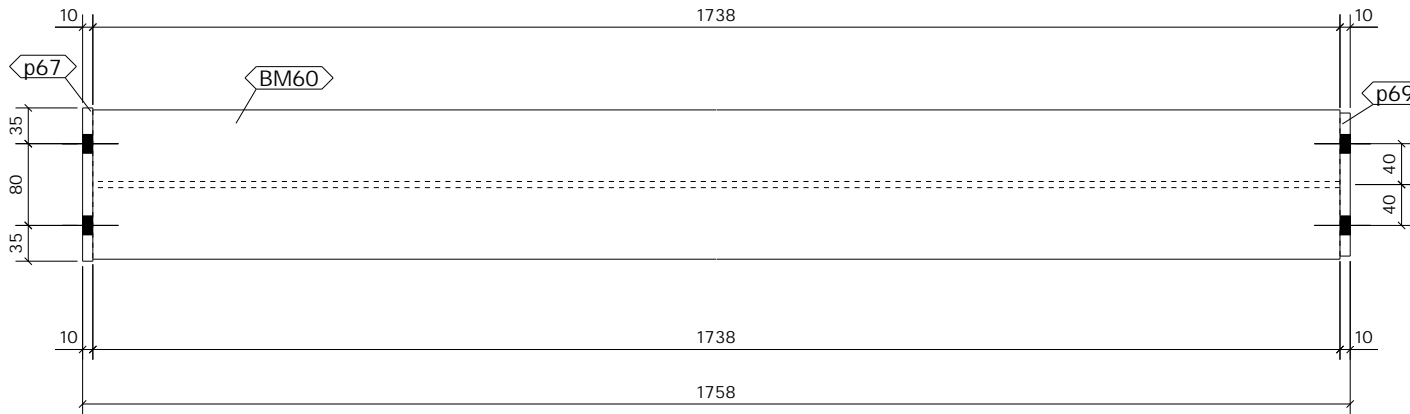

TOP VIEW
1:5

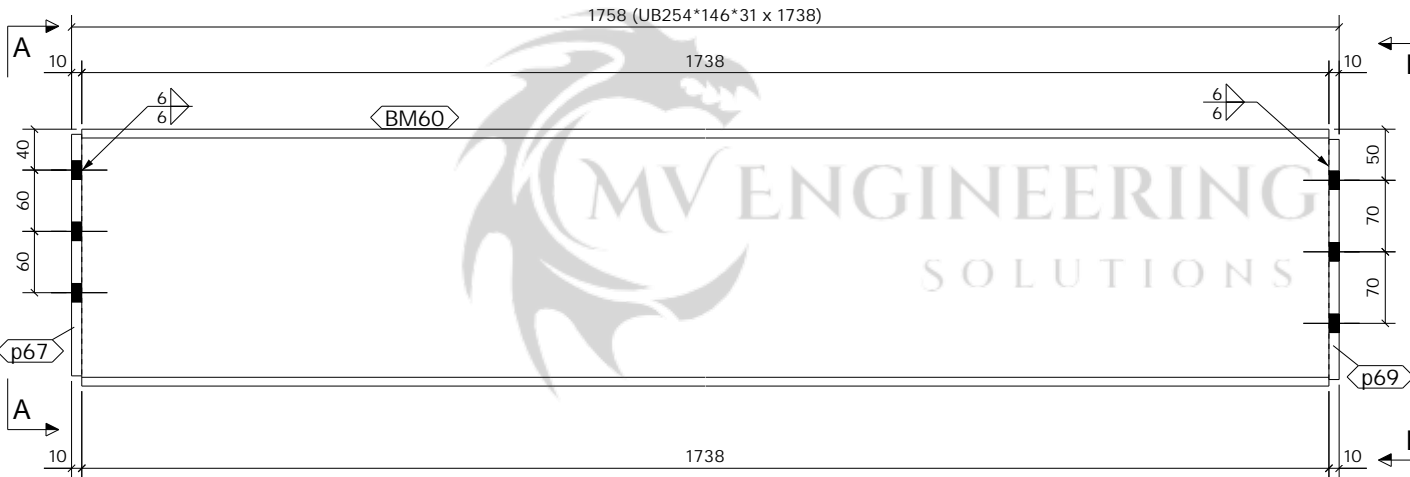

FRONT VIEW
1:5

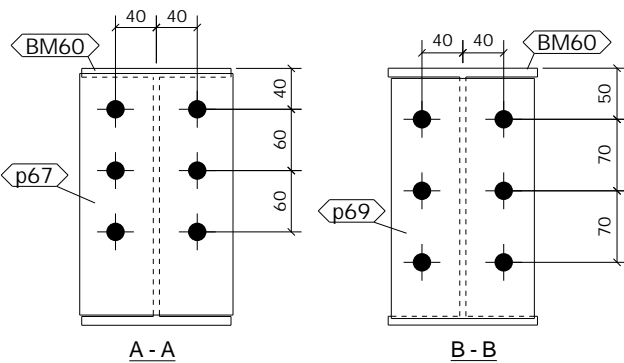

1 No. BEAM

REQUIRED AS DRAWN MARKED BM62

SHOP MATERIAL LIST FOR 1 ASSEMBLY

Mark	Size	Grade	No.	Length (mm)	Area (m ²)	Weight (kg)
BM60	UB254*146*31	S275	1	1738	1.877	53.5
p67	FLT10*150	S275	1	236	0.079	2.8
p69	FLT10*140	S275	1	235	0.073	2.6
				Total	2.028	58.8

GENERAL NOTES

All Holes to be **22** Dia UNO Slot hole length is to outside
 All Welds to be **6** FW. UNO

All Steelwork Manufactured to:
 BS EN 1090-2: Execution Class **EXC2** U.N.O.

FINISH **GALVANISED**

LOT **0** QTY **1**

PHASE **1** QTY **1**

FABRICATION STATUS

Sawn by: _____ Date: _____

Fabricated by: _____ Date: _____

Welded by: _____ Date: _____

Loaded by: _____ Date: _____

Checked by: _____ Date: _____

A	ISSUED FOR APPROVAL			
	PCS	25.01.2023	SK	25.01.2023
REV	By	Date	By	Date
MARK	DESCRIPTION	CREATED	CHECKED	

CLIENT: _____ **DATE CREATED:** 23.01.2023

PROJECT: Ebenezer Street **DRAWN BY:** PCS

CONTRACT NO: T8298 **DRAWING NO:** [BM.62] **REV:** A

ASSEMBLY / SUB ASSEMBLY STATUS	
1	THIS IS IT'S OWN ASSEMBLY

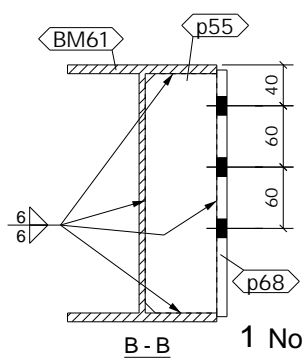
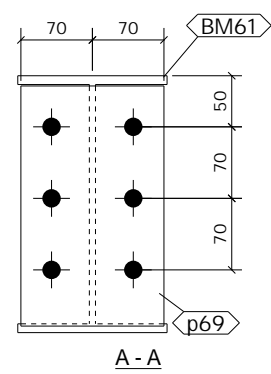
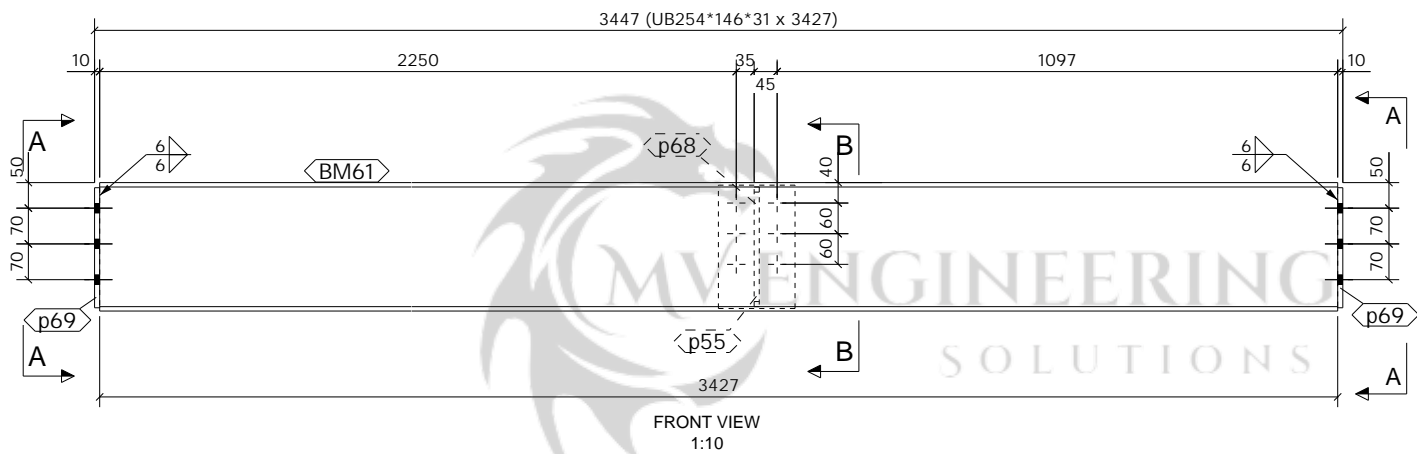
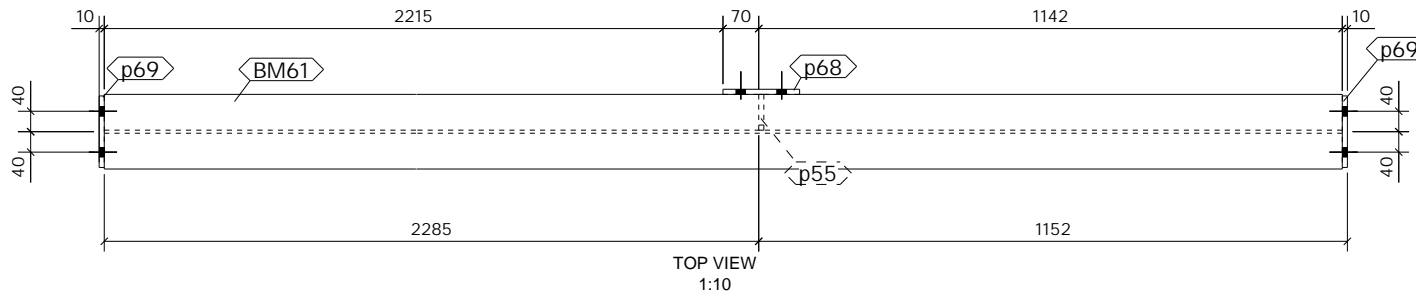

1 No. BEAM

REQUIRED AS DRAWN MARKED BM63

SHOP MATERIAL LIST FOR 1 ASSEMBLY

Mark	Size	Grade	No.	Length (mm)	Area (m ²)	Weight (kg)
BM61	UB254*146*31	S275	1	3427	3.693	105.4
p55	FLT10*70	S275	1	234	0.039	1.3
p68	FLT10*150	S275	1	241	0.080	2.8
p69	FLT10*140	S275	2	235	0.147	5.2
Total					3.958	114.7

GENERAL NOTES

All Holes to be **22** Dia UNO Slot hole length is to outside
 All Welds to be **6** FW. UNO

All Steelwork Manufactured to:
 BS EN 1090-2: Execution Class **EXC2** U.N.O.

FINISH **GALVANISED**
 LOT **0** QTY **1**
 PHASE **1** QTY **1**

FABRICATION STATUS

Sawn by: _____ Date: _____
 Fabricated by: _____ Date: _____
 Welded by: _____ Date: _____
 Loaded by: _____ Date: _____
 Checked by: _____ Date: _____

REV	DESCRIPTION	ISSUED FOR APPROVAL			
		By	Date	By	Date
A		PCS	25.01.2023	SK	25.01.2023
MARK		CREATED		CHECKED	

CLIENT: Ebenezzer Street **DATE CREATED:** 24.01.2023

PROJECT: Ebenezzer Street **DRAWN BY:** PCS

CONTRACT NO: T8298 **DRAWING NO:** [BM.63] **REV:** A

ASSEMBLY / SUB ASSEMBLY STATUS	
1	THIS IS IT'S OWN ASSEMBLY

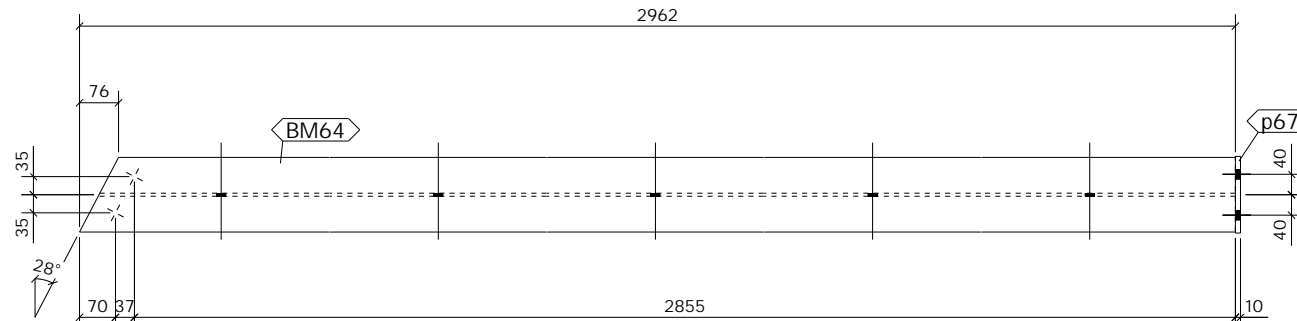

TOP VIEW
1:10

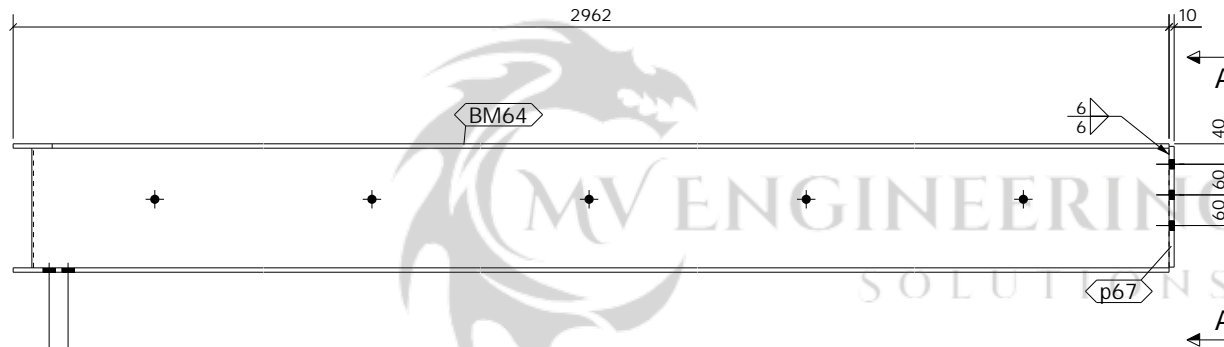

FRONT VIEW
1:10

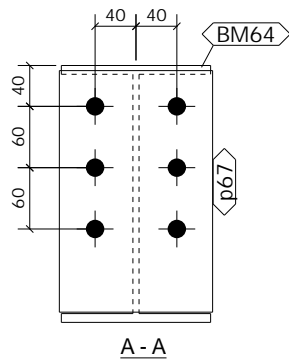

A - A

1 No. BEAM

REQUIRED AS DRAWN MARKED BM64

SHOP MATERIAL LIST FOR 1 ASSEMBLY

Mark	Size	Grade	No.	Length (mm)	Area (m ²)	Weight (kg)
BM64	UB254*146*31	S275	1	2962	3.152	89.9
p67	FLT10*150	S275	1	236	0.079	2.8
				Total	3.231	92.7

GENERAL NOTES

All Holes to be 22 Dia UNO Slot hole length is to outside
 All Welds to be 6 FW. UNO

All Steelwork Manufactured to:
 BS EN 1090-2: Execution Class EXC2 U.N.O.

FINISH **GALVANISED**
 LOT 0 QTY 1
 PHASE 1 QTY 1

FABRICATION STATUS

Sawn by: _____ Date: _____
 Fabricated by: _____ Date: _____
 Welded by: _____ Date: _____
 Loaded by: _____ Date: _____
 Checked by: _____ Date: _____

REV	DESCRIPTION	ISSUED FOR APPROVAL			
		By	Date	By	Date
A		PCS	25.01.2023	SK	25.01.2023
MARK		CREATED		CHECKED	

CLIENT: _____ DATE CREATED: 23.01.2023

PROJECT: Ebenezer Street DRAWN BY: PCS

CONTRACT NO: T8298 DRAWING NO: [BM.64] REV: A

ASSEMBLY / SUB ASSEMBLY STATUS	
1	THIS IS IT'S OWN ASSEMBLY

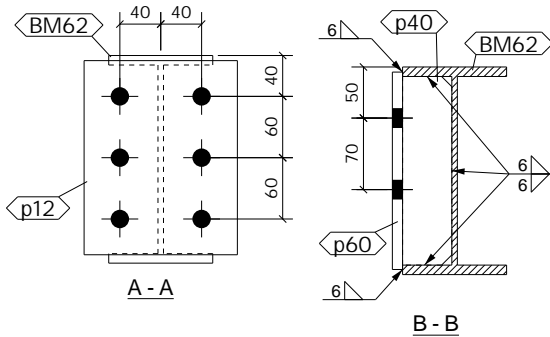
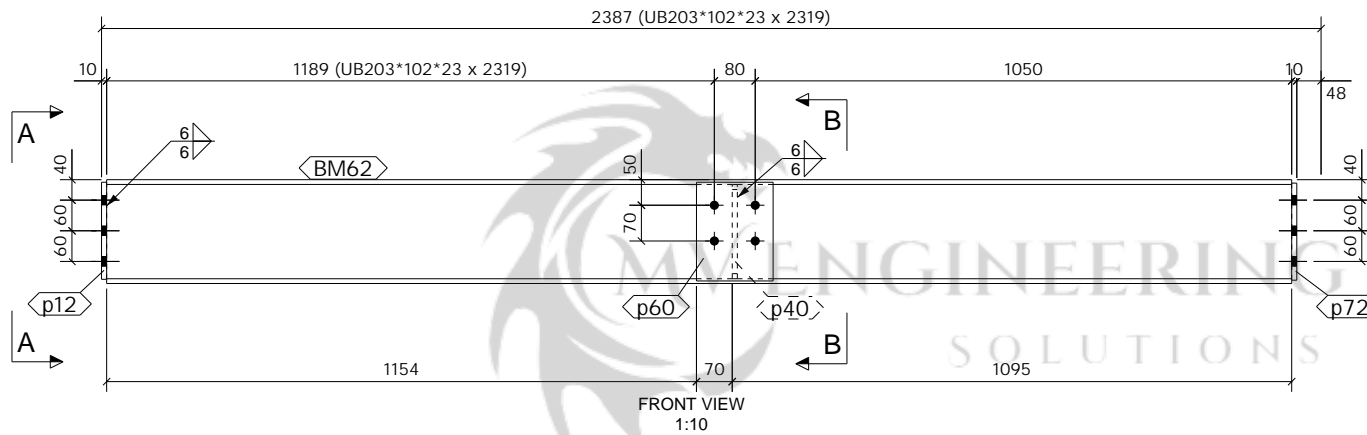
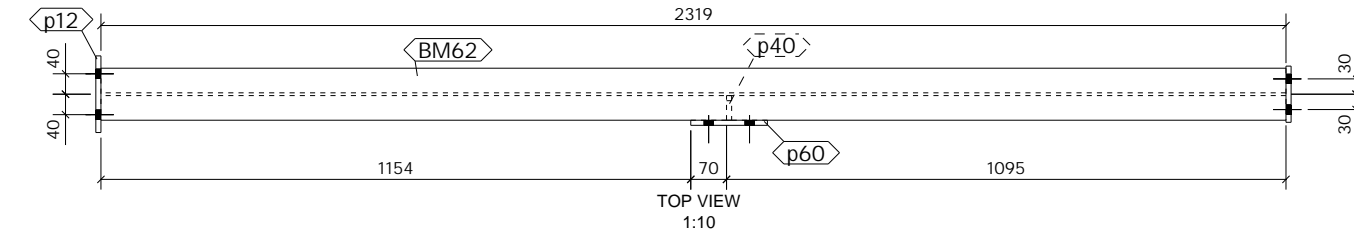

1 No. BEAM

REQUIRED AS DRAWN MARKED BM65

SHOP MATERIAL LIST FOR 1 ASSEMBLY

Mark	Size	Grade	No.	Length (mm)	Area (m ²)	Weight (kg)
BM62	UB203*102*23	S275	1	2319	1.868	52.6
p12	FLT10*150	S275	1	190	0.064	2.2
p40	PLT10*48.2	S275	1	185	0.022	0.7
p60	FLT10*150	S275	1	193	0.065	2.3
p72	FLT10*110	S275	1	190	0.048	1.6
Total					2.066	59.5

GENERAL NOTES

All Holes to be **22** Dia UNO Slot hole length is to outside
 All Welds to be **6** FW. UNO

All Steelwork Manufactured to:
 BS EN 1090-2: Execution Class **EXC2** U.N.O.

FINISH **S.B. & PRIME**
 LOT **0** QTY **1**
 PHASE **1** QTY **1**

FABRICATION STATUS

Sawn by: _____ Date: _____
 Fabricated by: _____ Date: _____
 Welded by: _____ Date: _____
 Loaded by: _____ Date: _____
 Checked by: _____ Date: _____

B	ISSUED FOR APPROVAL	PCS	01.02.2023	SK	01.02.2023
A	ISSUED FOR APPROVAL	PCS	25.01.2023	SK	25.01.2023
REV		By	Date	By	Date
MARK	DESCRIPTION	CREATED	CHECKED		

CLIENT: _____ **DATE CREATED:** 23.01.2023

PROJECT: Ebenezer Street **DRAWN BY:** PCS

CONTRACT NO: T8298 **DRAWING NO:** [BM.65] **REV:** B

ASSEMBLY / SUB ASSEMBLY STATUS	
1	THIS IS IT'S OWN ASSEMBLY

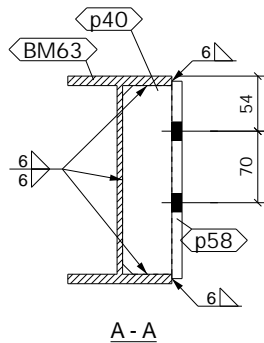
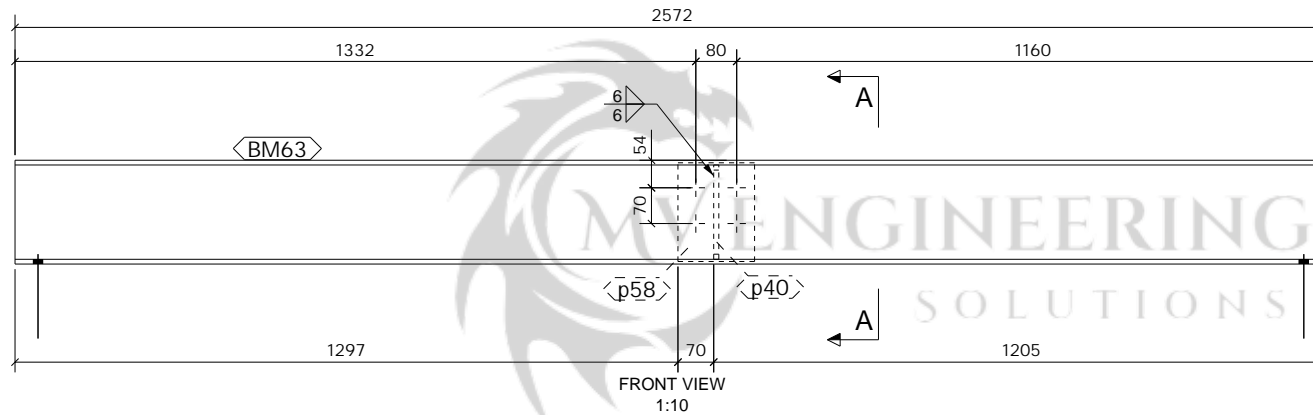
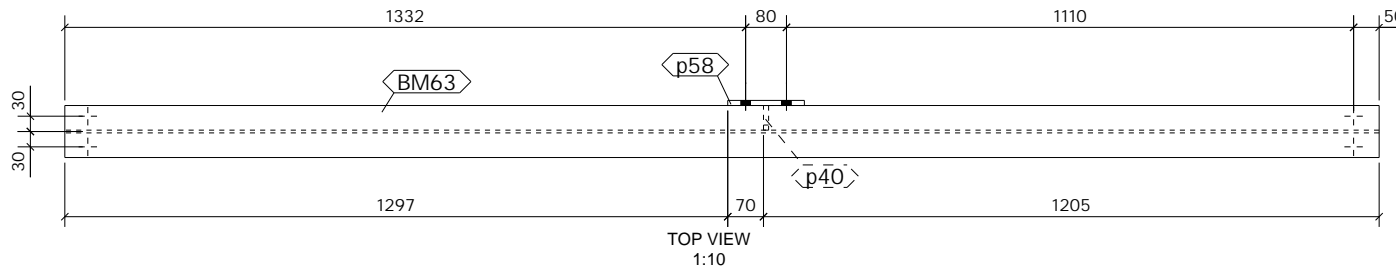

1 No. BEAM

REQUIRED AS DRAWN MARKED BM66

SHOP MATERIAL LIST FOR 1 ASSEMBLY

Mark	Size	Grade	No.	Length (mm)	Area (m ²)	Weight (kg)
BM63	UB203*102*23	S275	1	2572	2.071	58.4
p40	PLT10*48.2	S275	1	185	0.022	0.7
p58	FLT10*150	S275	1	193	0.065	2.3
Total					2.158	61.3

GENERAL NOTES

All Holes to be 22 Dia UNO Slot hole length is to outside
 All Welds to be 6 FW. UNO

All Steelwork Manufactured to:
 BS EN 1090-2: Execution Class **EXC2** U.N.O.

FINISH **S.B. & PRIME**
 LOT **0** QTY **1**
 PHASE **1** QTY **1**

FABRICATION STATUS

Sawn by: _____ Date: _____
 Fabricated by: _____ Date: _____
 Welded by: _____ Date: _____
 Loaded by: _____ Date: _____
 Checked by: _____ Date: _____

REV	DESCRIPTION	ISSUED FOR APPROVAL			
		By	Date	By	Date
A		PCS	25.01.2023	SK	25.01.2023
MARK		CREATED		CHECKED	

CLIENT: _____ DATE CREATED: 23.01.2023

PROJECT: Ebenezer Street DRAWN BY: PCS

CONTRACT NO: T8298 DRAWING NO: [BM.66] REV: A

ASSEMBLY / SUB ASSEMBLY STATUS	
1	THIS IS IT'S OWN ASSEMBLY

SHOP MATERIAL LIST FOR 1 ASSEMBLY

Mark	Size	Grade	No.	Length (mm)	Area (m ²)	Weight (kg)
BM65	UB254*146*31	S275	1	5315	5.723	163.5
p11	FLT10*150	S275	1	241	0.080	2.8
p13	FLT10*70	S275	1	234	0.039	1.3
p71	FLT10*150	S275	1	240	0.080	2.8
Total					5.921	170.4

GENERAL NOTES

All Holes to be **22** Dia UNO Slot hole length is to outside
 All Welds to be **6** FW. UNO

All Steelwork Manufactured to:
 BS EN 1090-2: Execution Class **EXC2** U.N.O.

FINISH **S.B. & PRIME**
 LOT **0** QTY **1**
 PHASE **1** QTY **1**

FABRICATION STATUS

Sawn by: _____ Date: _____
 Fabricated by: _____ Date: _____
 Welded by: _____ Date: _____
 Loaded by: _____ Date: _____
 Checked by: _____ Date: _____

B	ISSUED FOR APPROVAL	PCS	01.02.2023	SK	01.02.2023
A	ISSUED FOR APPROVAL	PCS	25.01.2023	SK	25.01.2023
REV		By	Date	By	Date
MARK	DESCRIPTION	CREATED	CHECKED		

CLIENT: _____ **DATE CREATED:** 23.01.2023

PROJECT: Ebenezer Street **DRAWN BY:** PCS

CONTRACT NO: T8298 **DRAWING NO:** [BM.67] **REV:** B

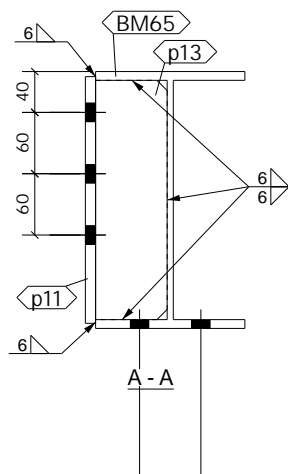
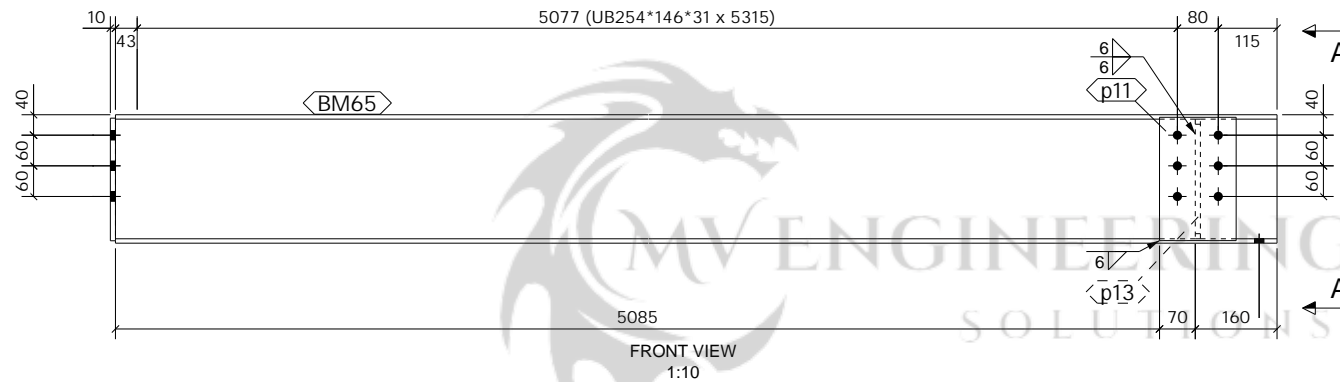
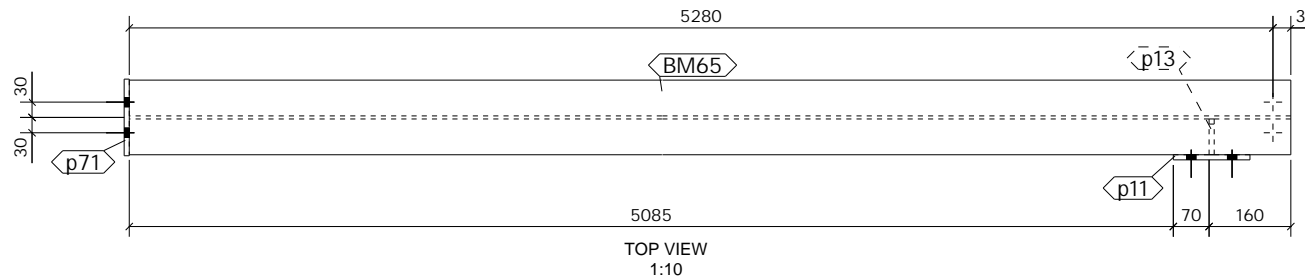

1 No. BEAM

REQUIRED AS DRAWN MARKED BM67

ASSEMBLY / SUB ASSEMBLY STATUS	
1	THIS IS IT'S OWN ASSEMBLY

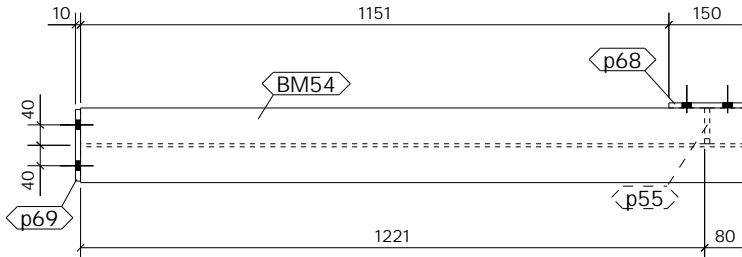

TOP VIEW
1:10

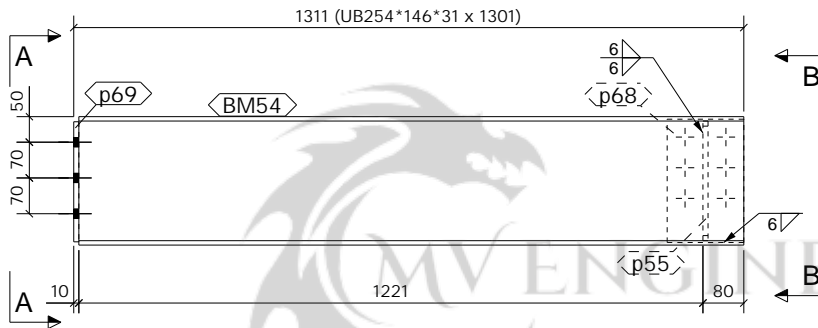

FRONT VIEW
1:10

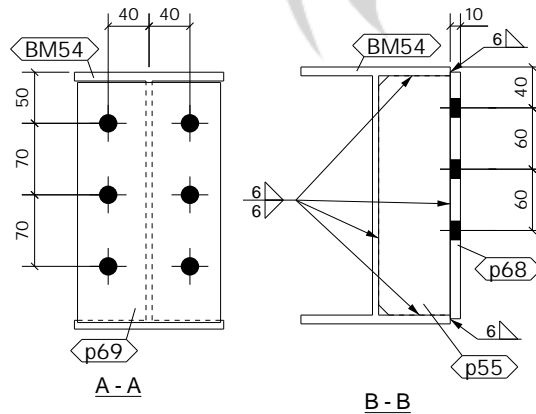

1 No. BEAM

REQUIRED AS DRAWN MARKED BM68

SHOP MATERIAL LIST FOR 1 ASSEMBLY

Mark	Size	Grade	No.	Length (mm)	Area (m ²)	Weight (kg)
BM54	UB254*146*31	S275	1	1301	1.407	40.0
p55	FLT10*70	S275	1	234	0.039	1.3
p68	FLT10*150	S275	1	241	0.080	2.8
p69	FLT10*140	S275	1	235	0.073	2.6
Total					1.599	46.7

GENERAL NOTES

All Holes to be 22 Dia UNO Slot hole length is to outside
All Welds to be 6 FW. UNO

All Steelwork Manufactured to:
BS EN 1090-2: Execution Class **EXC2** U.N.O.

FINISH **GALVANISED**
LOT **0** QTY **1**
PHASE **1** QTY **1**

FABRICATION STATUS

Sawn by: _____ Date: _____
Fabricated by: _____ Date: _____
Welded by: _____ Date: _____
Loaded by: _____ Date: _____
Checked by: _____ Date: _____

REV	DESCRIPTION	ISSUED FOR APPROVAL			
		By	Date	By	Date
A		PCS	25.01.2023	SK	25.01.2023
MARK		CREATED		CHECKED	

CLIENT: _____ DATE CREATED: 25.01.2023

PROJECT: Ebenezer Street DRAWN BY: PCS

CONTRACT NO: T8298 DRAWING NO: [BM.68] REV: A

ASSEMBLY / SUB ASSEMBLY STATUS	
1	THIS IS IT'S OWN ASSEMBLY

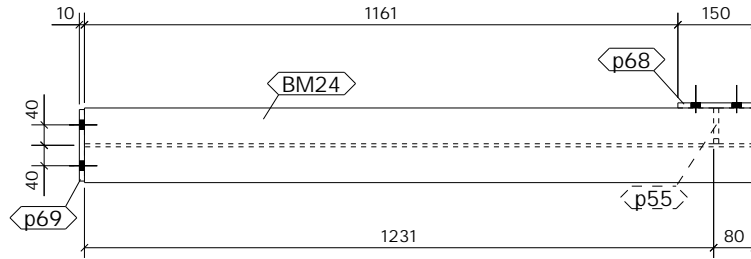

TOP VIEW
1:10

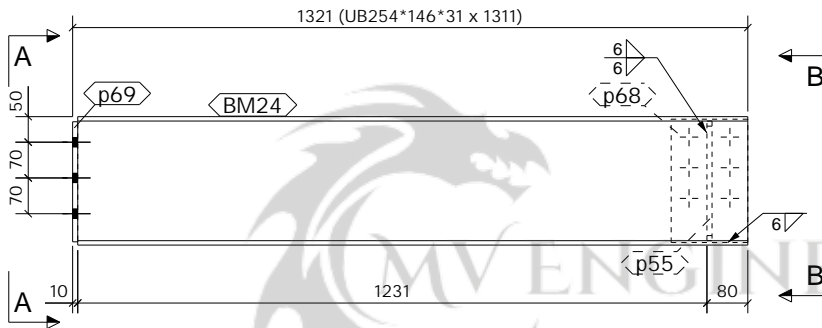

FRONT VIEW
1:10

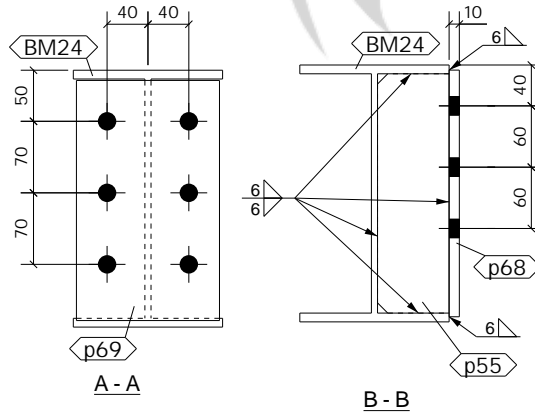

1 No. BEAM

REQUIRED AS DRAWN MARKED BM69

SHOP MATERIAL LIST FOR 1 ASSEMBLY

Mark	Size	Grade	No.	Length (mm)	Area (m ²)	Weight (kg)
BM24	UB254*146*31	S275	1	1311	1.418	40.3
p55	FLT10*70	S275	1	234	0.039	1.3
p68	FLT10*150	S275	1	241	0.080	2.8
p69	FLT10*140	S275	1	235	0.073	2.6
Total					1.610	47.0

GENERAL NOTES

All Holes to be 22 Dia UNO Slot hole length is to outside
All Welds to be 6 FW. UNO

All Steelwork Manufactured to:
BS EN 1090-2: Execution Class **EXC2** U.N.O.

FINISH **GALVANISED**
LOT **0** QTY **1**
PHASE **1** QTY **1**

FABRICATION STATUS

Sawn by: _____ Date: _____
Fabricated by: _____ Date: _____
Welded by: _____ Date: _____
Loaded by: _____ Date: _____
Checked by: _____ Date: _____

A	ISSUED FOR APPROVAL	APPROVAL			
		PCS	25.01.2023	SK	25.01.2023
REV	DESCRIPTION	By	Date	By	Date
MARK		CREATED	CHECKED		

CLIENT: _____ DATE CREATED: 25.01.2023

PROJECT: Ebenezer Street DRAWN BY: PCS

CONTRACT NO: T8298 DRAWING NO: [BM.69] REV: A

ASSEMBLY / SUB ASSEMBLY STATUS	
1	THIS IS IT'S OWN ASSEMBLY

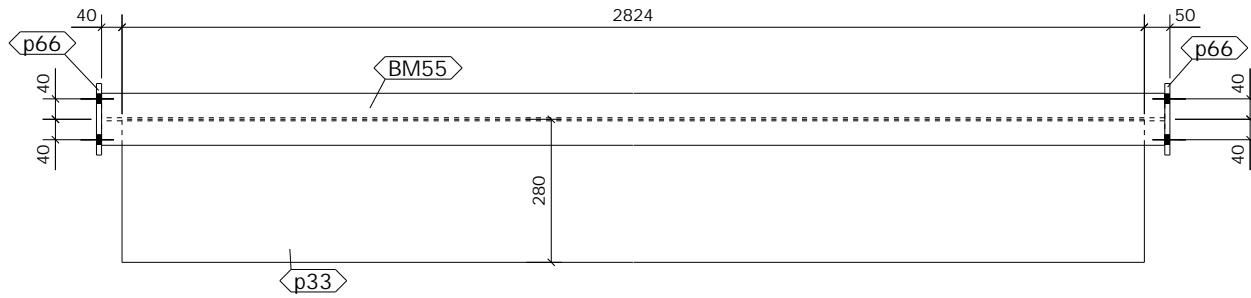

TOP VIEW
1:10

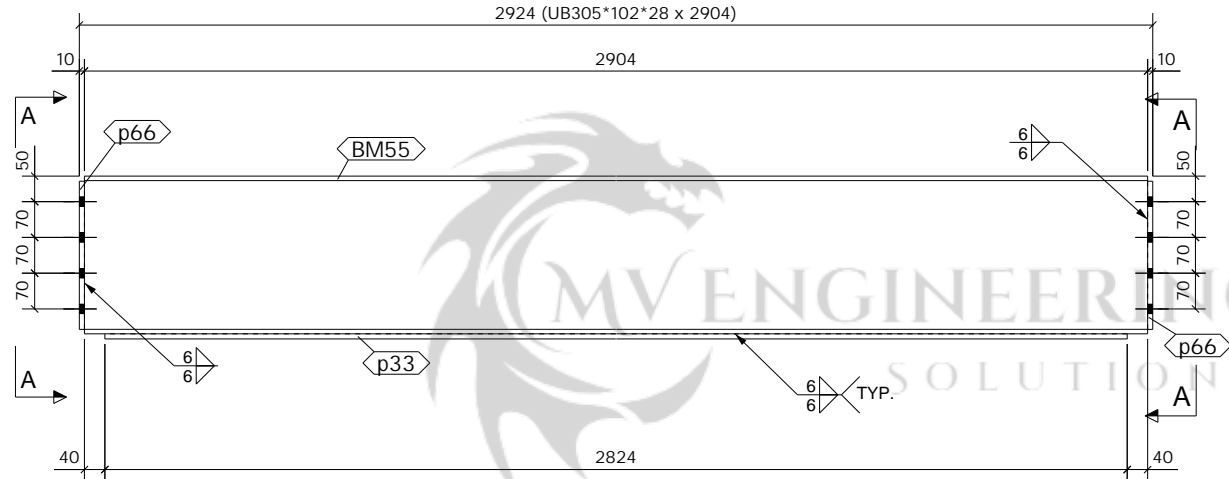

FRONT VIEW
1:10

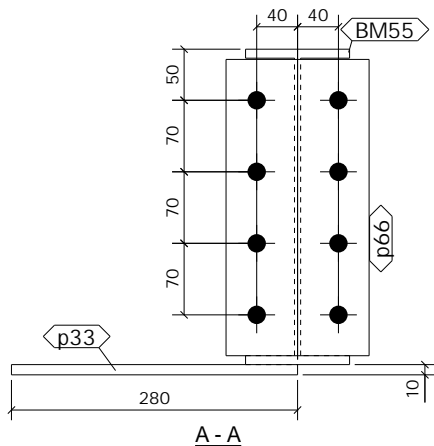

1 No. BEAM

REQUIRED AS DRAWN MARKED BM70

SHOP MATERIAL LIST FOR 1 ASSEMBLY

Mark	Size	Grade	No.	Length (mm)	Area (m ²)	Weight (kg)
BM55	UB305*102*28	S275	1	2904	2.948	80.7
p33	PL10*280	S275	1	2824	1.644	62.1
p66	FLT10*140	S275	2	290	0.180	6.4
Total					4.771	149.1

GENERAL NOTES

All Holes to be **22 Dia UNO** Slot hole length is to outside
 All Welds to be **6 FW. UNO**

All Steelwork Manufactured to:
 BS EN 1090-2: Execution Class **EXC2** U.N.O.

FINISH **GALVANISED**

LOT **0** QTY **1**

PHASE **1** QTY **1**

FABRICATION STATUS

Sawn by: _____ Date: _____

Fabricated by: _____ Date: _____

Welded by: _____ Date: _____

Loaded by: _____ Date: _____

Checked by: _____ Date: _____

B	ISSUED FOR APPROVAL	PCS	01.02.2023	SK	01.02.2023
A	ISSUED FOR APPROVAL	PCS	25.01.2023	SK	25.01.2023
REV	DESCRIPTION	By	Date	By	Date
MARK		CREATED	CHECKED		

CLIENT: _____ **DATE CREATED:** 23.01.2023

PROJECT: Ebenezer Street **DRAWN BY:** PCS

CONTRACT NO: T8298 **DRAWING NO:** [BM.70] **REV:** B

ASSEMBLY / SUB ASSEMBLY STATUS	
1	THIS IS IT'S OWN ASSEMBLY

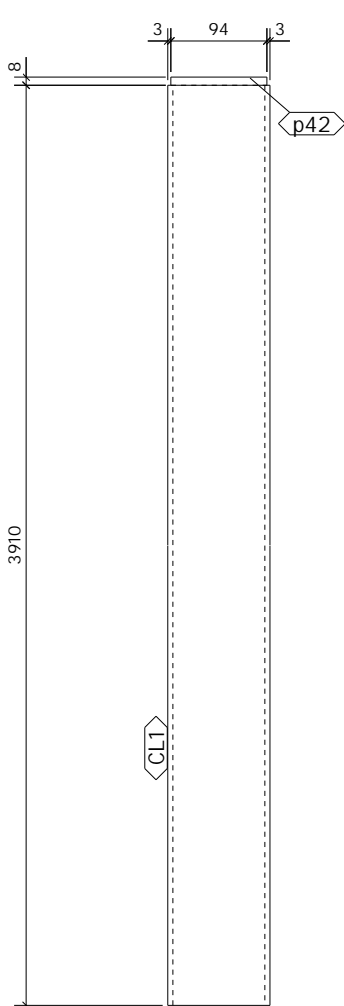

LEFTSIDE VIEW
1:5

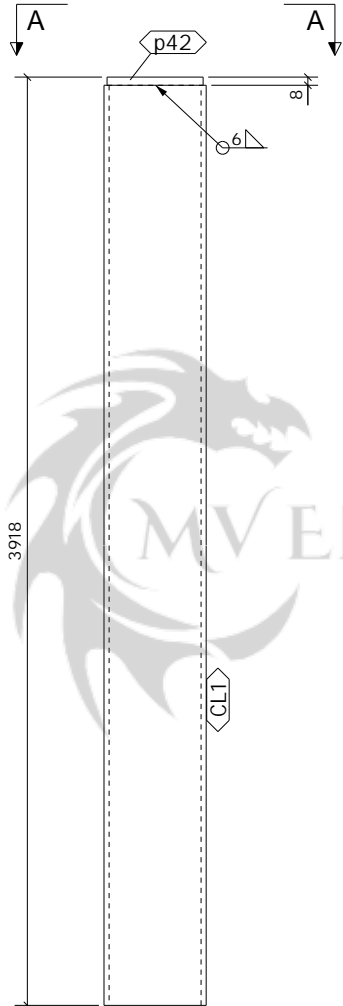

FRONT VIEW
1:5

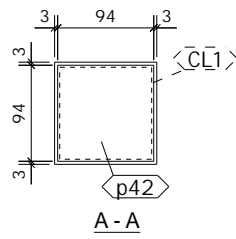

A - A

SHOP MATERIAL LIST FOR 1 ASSEMBLY						
Mark	Size	Grade	No.	Length (mm)	Area (m ²)	Weight (kg)
CL1	SHS100*100*5.0	S275	1	3910	1.566	58.3
p42	PLT8*94	S275	1	94	0.021	0.6
Total					1.587	58.9

GENERAL NOTES

All Holes to be **22** Dia UNO Slot hole length is to outside
 All Welds to be **6** FW. UNO

All Steelwork Manufactured to:
 BS EN 1090-2: Execution Class **EXC2** U.N.O.

FINISH **S.B. & PRIME**

LOT **0** QTY **1**
 PHASE **1** QTY **1**

FABRICATION STATUS	
Sawn by: _____	Date: _____
Fabricated by: _____	Date: _____
Welded by: _____	Date: _____
Loaded by: _____	Date: _____
Checked by: _____	Date: _____



A	ISSUED FOR APPROVAL	BY		DATE	
		PCS	SK	25.01.2023	25.01.2023
REV		By	Date	By	Date
MARK	DESCRIPTION	CREATED	CHECKED		

CLIENT: _____ **DATE CREATED:** 24.01.2023

PROJECT: Ebenezer Street **DRAWN BY:** PCS

CONTRACT NO: T8298 **DRAWING NO:** [CL.1] **REV:** A

1 No. COLUMN REQUIRED AS DRAWN MARKED CL1

ASSEMBLY / SUB ASSEMBLY STATUS	
1	THIS IS IT'S OWN ASSEMBLY

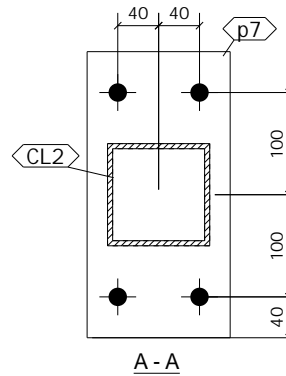
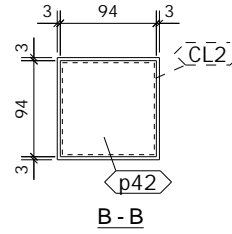
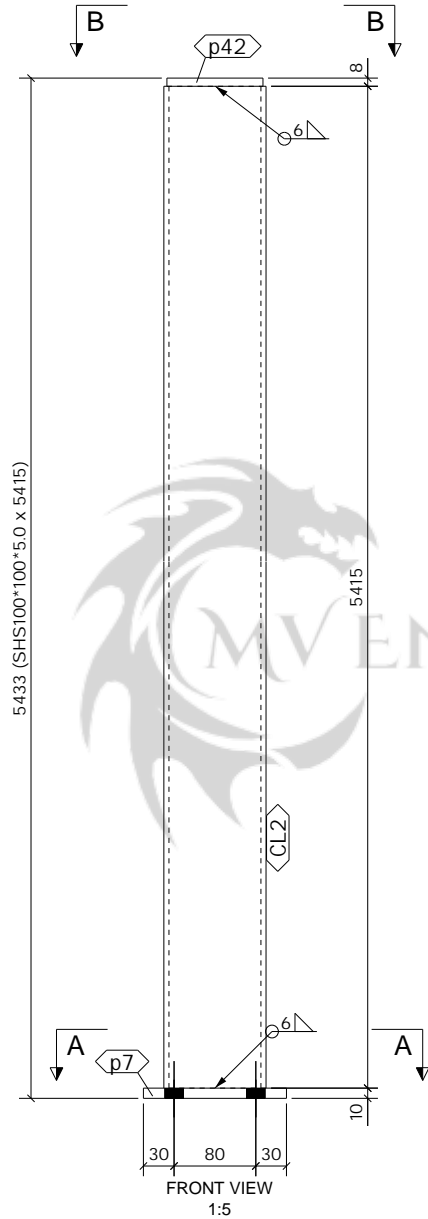
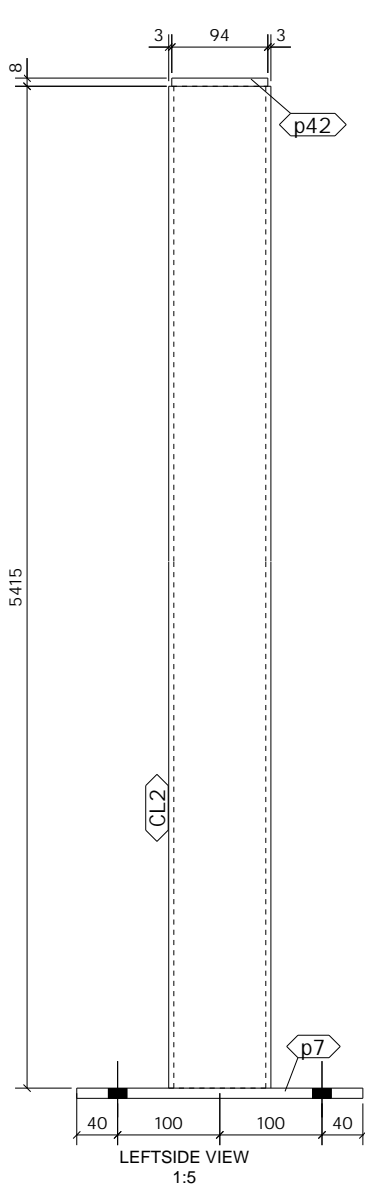

1 No. COLUMN

REQUIRED AS DRAWN MARKED CL2

SHOP MATERIAL LIST FOR 1 ASSEMBLY

Mark	Size	Grade	No.	Length (mm)	Area (m ²)	Weight (kg)
CL2	SHS100*100*5.0	S275	1	5415	2.168	80.8
p7	FLT10*140	S275	1	280	0.087	3.1
p42	PLT8*94	S275	1	94	0.021	0.6
Total					2.275	84.4

GENERAL NOTES

All Holes to be 22 Dia UNO Slot hole length is to outside
 All Welds to be 6 FW. UNO

All Steelwork Manufactured to:
 BS EN 1090-2: Execution Class **EXC2** U.N.O.

FINISH **S.B. & PRIME**
 LOT **0** QTY **1**
 PHASE **1** QTY **1**

FABRICATION STATUS

Sawn by: _____ Date: _____
 Fabricated by: _____ Date: _____
 Welded by: _____ Date: _____
 Loaded by: _____ Date: _____
 Checked by: _____ Date: _____

A	ISSUED FOR APPROVAL	PCS	25.01.2023	SK	25.01.2023
		By	Date	By	Date
REV	DESCRIPTION	CREATED	CHECKED		

CLIENT: _____ DATE CREATED: 24.01.2023

PROJECT: Ebenezer Street DRAWN BY: PCS

CONTRACT NO: T8298 DRAWING NO: [CL.2] REV: A

ASSEMBLY / SUB ASSEMBLY STATUS	
1	THIS IS IT'S OWN ASSEMBLY

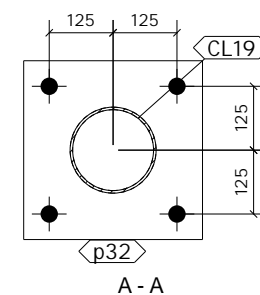
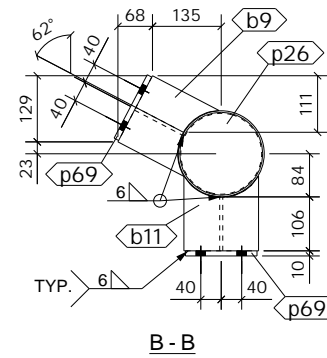
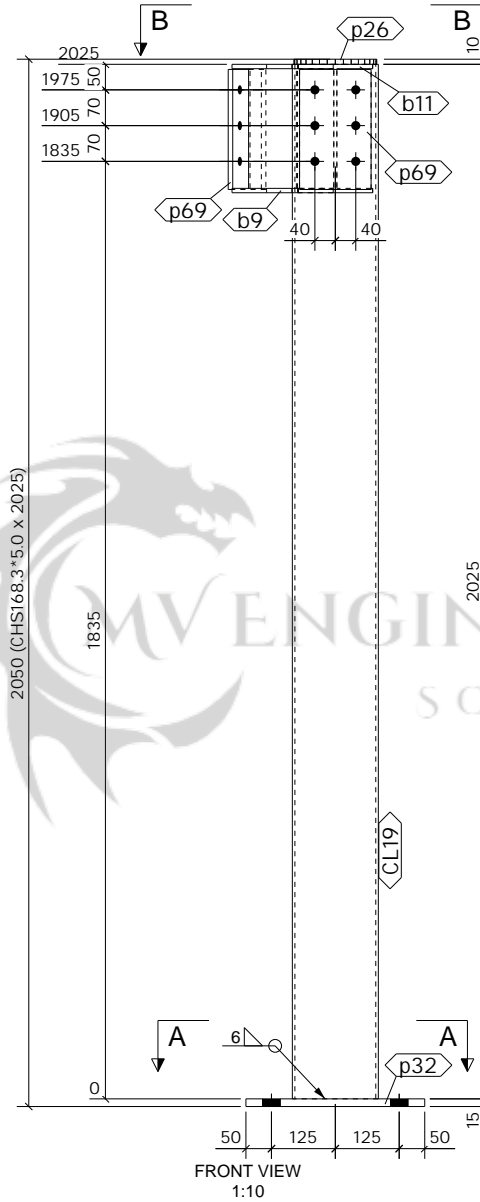
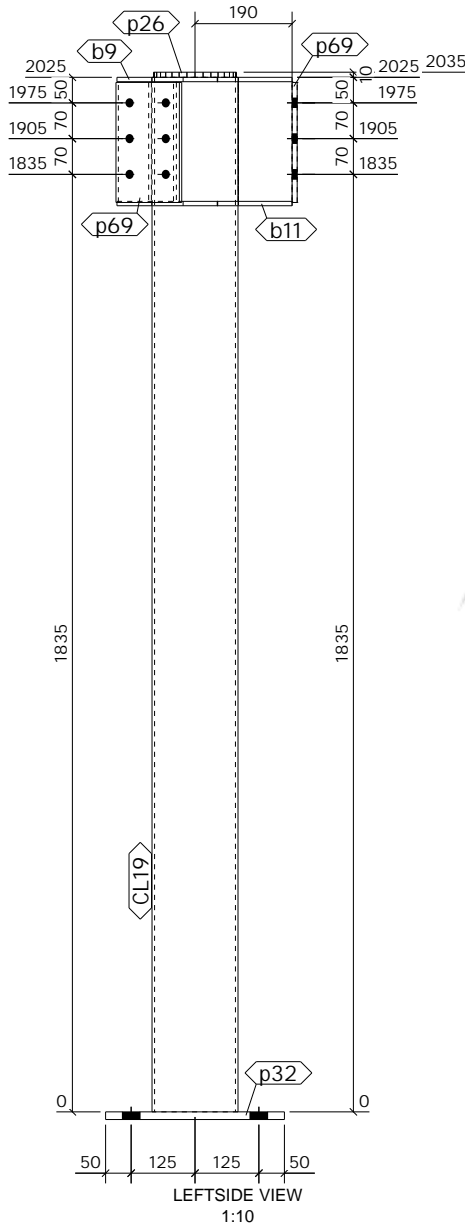

SHOP MATERIAL LIST FOR 1 ASSEMBLY

Mark	Size	Grade	No.	Length (mm)	Area (m ²)	Weight (kg)
CL19	CHS168.3*5.0	S275	1	2025	1.070	40.3
b9	UB254*146*31	S275	1	147	0.130	3.5
b11	UB254*146*31	S275	1	147	0.130	3.5
p26	PLT10*161.5	S275	1	162	0.046	1.6
p32	FLT15*350	S275	1	350	0.266	14.4
p69	FLT10*140	S275	2	235	0.147	5.2
Total					1.789	68.5

GENERAL NOTES

All Holes to be **22** Dia UNO Slot hole length is to outside
 All Welds to be **6** FW. UNO

All Steelwork Manufactured to:
 BS EN 1090-2: Execution Class **EXC2** U.N.O.

FINISH **GALVANISED**

LOT **0** QTY **1**

PHASE **1** QTY **1**

FABRICATION STATUS

Sawn by: _____ Date: _____

Fabricated by: _____ Date: _____

Welded by: _____ Date: _____

Loaded by: _____ Date: _____

Checked by: _____ Date: _____

REV	MARK	DESCRIPTION	ISSUED FOR APPROVAL		CREATED		CHECKED	
			By	Date	By	Date	By	Date
A			PCS	25.01.2023	SK	25.01.2023		

CLIENT: _____ **DATE CREATED:** 25.01.2023

PROJECT: Ebenezer Street **DRAWN BY:** PCS

CONTRACT NO: T8298 **DRAWING NO:** [CL.3] **REV:** A

ASSEMBLY / SUB ASSEMBLY STATUS	
1	THIS IS IT'S OWN ASSEMBLY

1 No. COLUMN REQUIRED AS DRAWN MARKED CL3

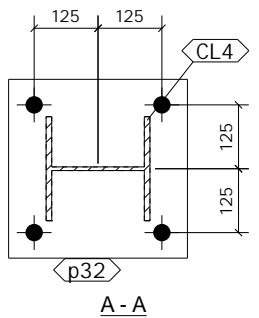
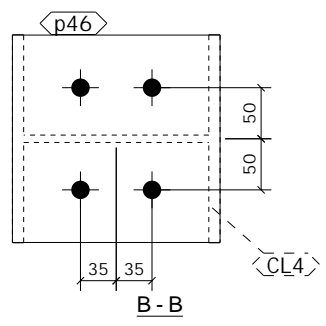
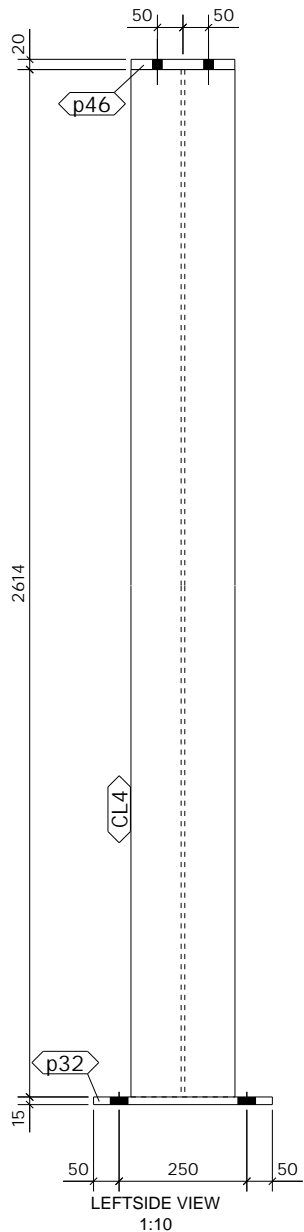

SHOP MATERIAL LIST FOR 1 ASSEMBLY

Mark	Size	Grade	No.	Length (mm)	Area (m ²)	Weight (kg)
CL4	UC203*203*46	S275	1	2614	3.165	118.7
p32	FLT15*350	S275	1	350	0.266	14.4
p46	PLT20*203	S275	1	203	0.099	6.5
				Total	3.529	139.6

GENERAL NOTES

All Holes to be **22** Dia UNO Slot hole length is to outside
 All Welds to be **6** FW. UNO

All Steelwork Manufactured to:
 BS EN 1090-2: Execution Class **EXC2** U.N.O.

FINISH **GALVANISED**
 LOT **0** QTY **1**
 PHASE **1** QTY **1**

FABRICATION STATUS

Sawn by: _____ Date: _____
 Fabricated by: _____ Date: _____
 Welded by: _____ Date: _____
 Loaded by: _____ Date: _____
 Checked by: _____ Date: _____

REV	MARK	DESCRIPTION	ISSUED FOR APPROVAL	
			By	Date
			PCS	25.01.2023
			SK	25.01.2023
			By	Date
			CREATED	CHECKED

CLIENT: Ebenezer Street
PROJECT: Ebenezer Street
CONTRACT NO: T8298
DATE CREATED: 24.01.2023
DRAWN BY: PCS
DRAWING NO: [CL.4]
REV: A

1 No. COLUMN

REQUIRED AS DRAWN MARKED CL4

ASSEMBLY / SUB ASSEMBLY STATUS	
1	THIS IS IT'S OWN ASSEMBLY



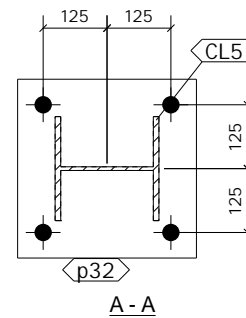
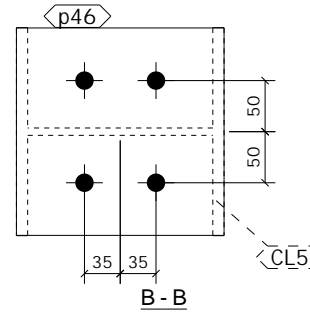
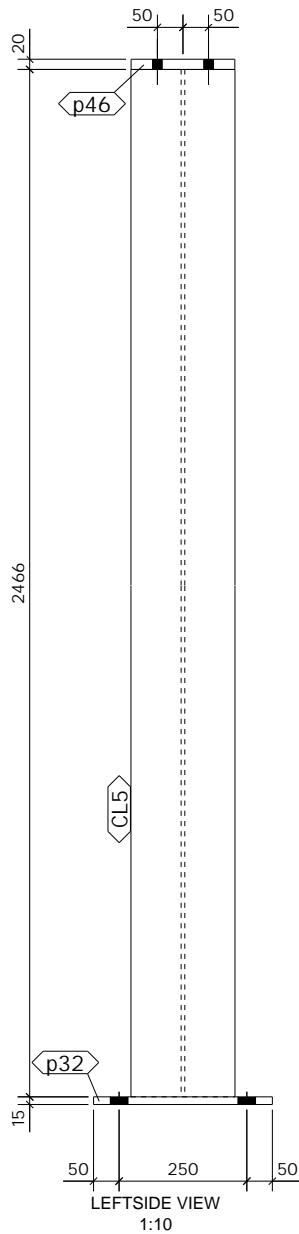

SHOP MATERIAL LIST FOR 1 ASSEMBLY

Mark	Size	Grade	No.	Length (mm)	Area (m ²)	Weight (kg)
CL5	UC203*203*46	S275	1	2466	2.987	112.0
p32	FLT15*350	S275	1	350	0.266	14.4
p46	PLT20*203	S275	1	203	0.099	6.5
Total					3.352	132.9

GENERAL NOTES

All Holes to be **22 Dia UNO** Slot hole length is to outside
 All Welds to be **6 FW. UNO**

All Steelwork Manufactured to:
 BS EN 1090-2: Execution Class **EXC2** U.N.O.

FINISH **GALVANISED**
 LOT **0** QTY **1**
 PHASE **1** QTY **1**

FABRICATION STATUS

Sawn by: _____ Date: _____
 Fabricated by: _____ Date: _____
 Welded by: _____ Date: _____
 Loaded by: _____ Date: _____
 Checked by: _____ Date: _____

REV	MARK	DESCRIPTION	ISSUED FOR APPROVAL			
			By	Date	By	Date
			PCS	25.01.2023	SK	25.01.2023
			CREATED		CHECKED	

CLIENT: Ebenezzer Street
DATE CREATED: 24.01.2023

PROJECT: Ebenezzer Street
DRAWN BY: PCS

CONTRACT NO: T8298
DRAWING NO: [CL.5]
REV: A

1 No. COLUMN

REQUIRED AS DRAWN MARKED CL5

ASSEMBLY / SUB ASSEMBLY STATUS	
1	THIS IS IT'S OWN ASSEMBLY



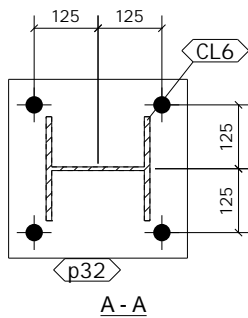
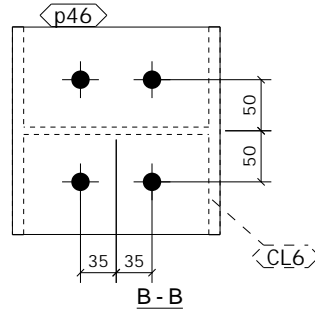
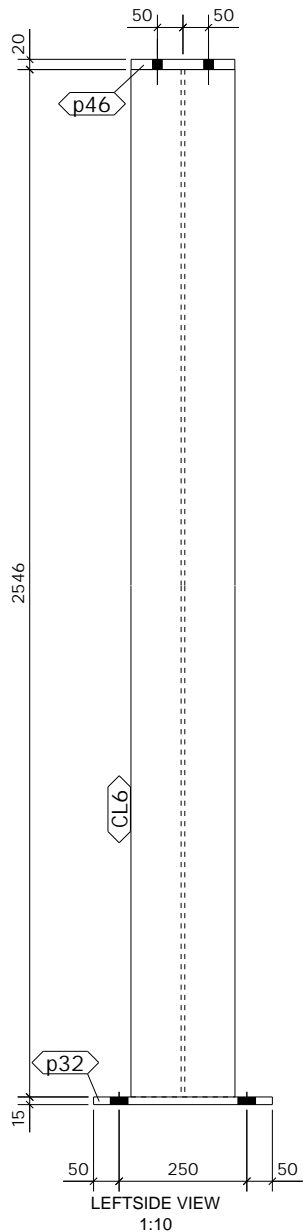

1 No. COLUMN

REQUIRED AS DRAWN MARKED CL6

SHOP MATERIAL LIST FOR 1 ASSEMBLY

Mark	Size	Grade	No.	Length (mm)	Area (m ²)	Weight (kg)
CL6	UC203*203*46	S275	1	2546	3.083	115.6
p32	FLT15*350	S275	1	350	0.266	14.4
p46	PLT20*203	S275	1	203	0.099	6.5
				Total	3.448	136.5

GENERAL NOTES

All Holes to be **22** Dia UNO Slot hole length is to outside
 All Welds to be **6** FW. UNO

All Steelwork Manufactured to:
 BS EN 1090-2: Execution Class **EXC2** U.N.O.

FINISH **GALVANISED**
 LOT **0** QTY **1**
 PHASE **1** QTY **1**

FABRICATION STATUS

Sawn by: _____ Date: _____
 Fabricated by: _____ Date: _____
 Welded by: _____ Date: _____
 Loaded by: _____ Date: _____
 Checked by: _____ Date: _____

REV	MARK	DESCRIPTION	ISSUED FOR APPROVAL		CREATED		CHECKED	
			By	Date	By	Date	By	Date
	A		PCS	25.01.2023	SK	25.01.2023		

CLIENT: _____ **DATE CREATED:** 24.01.2023

PROJECT: Ebenezer Street **DRAWN BY:** PCS

CONTRACT NO: T8298 **DRAWING NO:** [CL.6] **REV:** A

ASSEMBLY / SUB ASSEMBLY STATUS	
1	THIS IS IT'S OWN ASSEMBLY

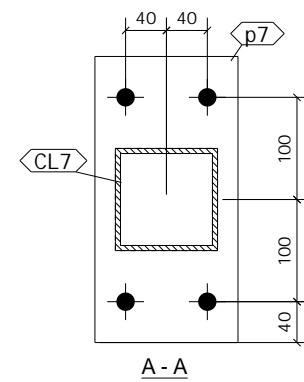
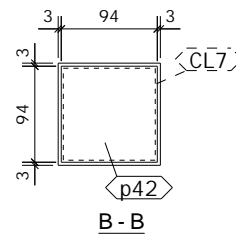
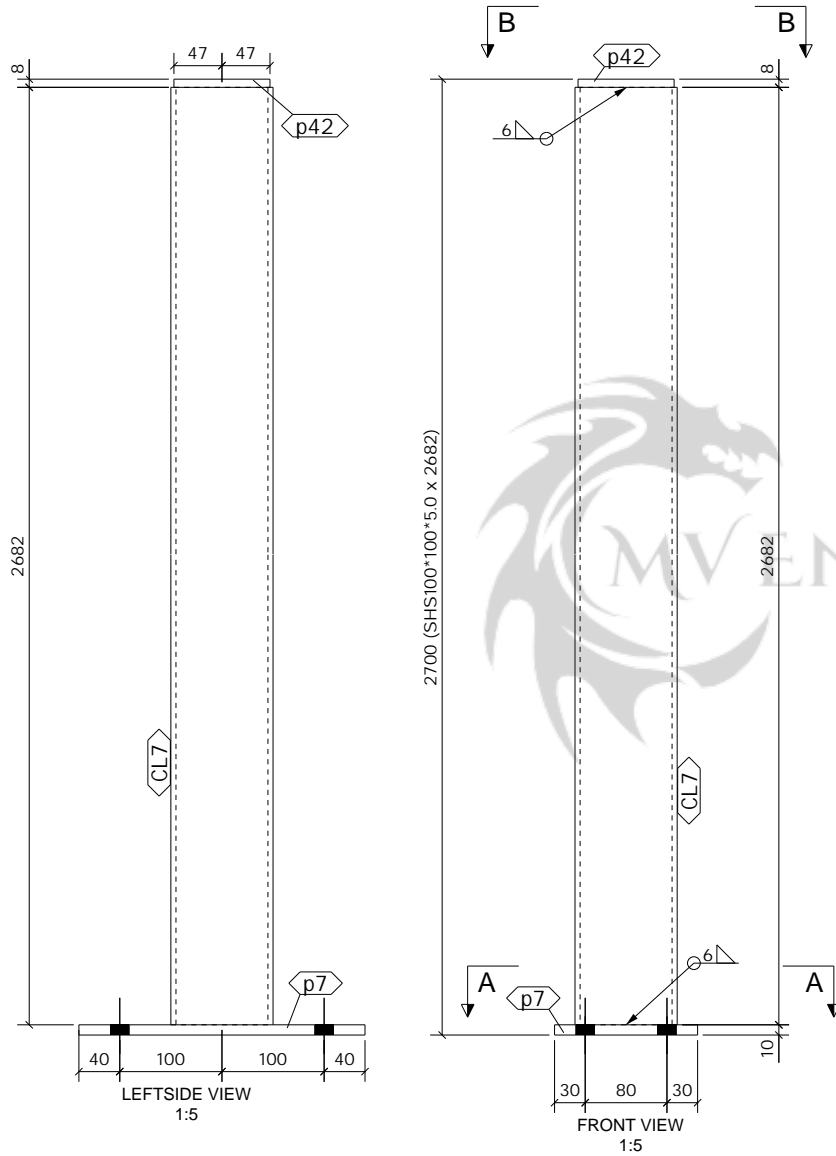

1 No. COLUMN

REQUIRED AS DRAWN MARKED CL7

ASSEMBLY / SUB ASSEMBLY STATUS	
1	THIS IS IT'S OWN ASSEMBLY

SHOP MATERIAL LIST FOR 1 ASSEMBLY

Mark	Size	Grade	No.	Length (mm)	Area (m ²)	Weight (kg)
CL7	SHS100*100*5.0	S275	1	2682	1.075	40.0
p7	FLT10*140	S275	1	280	0.087	3.1
p42	PLT8*94	S275	1	94	0.021	0.6
Total					1.182	43.6

GENERAL NOTES

All Holes to be **22** Dia UNO Slot hole length is to outside
 All Welds to be **6** FW. UNO

All Steelwork Manufactured to:
 BS EN 1090-2: Execution Class **EXC2** U.N.O.

FINISH **S.B. & PRIME**
 LOT **0** QTY **1**
 PHASE **1** QTY **1**

FABRICATION STATUS

Sawn by: _____ Date: _____
 Fabricated by: _____ Date: _____
 Welded by: _____ Date: _____
 Loaded by: _____ Date: _____
 Checked by: _____ Date: _____

REV	DESCRIPTION	ISSUED FOR APPROVAL			
		By	Date	By	Date
A		PCS	25.01.2023	SK	25.01.2023
MARK		CREATED		CHECKED	

CLIENT: Ebenezer Street **DATE CREATED:** 24.01.2023

PROJECT: Ebenezer Street **DRAWN BY:** PCS

CONTRACT NO: T8298 **DRAWING NO:** [CL.7] **REV:** A

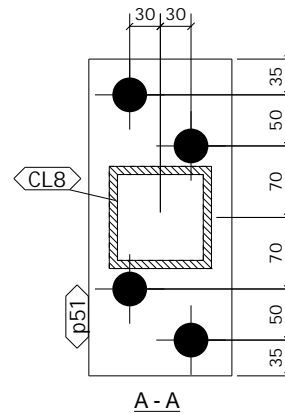
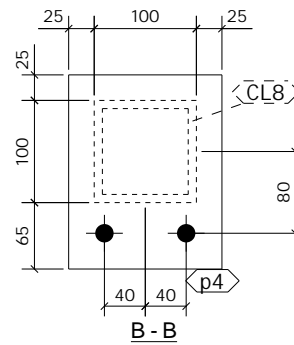
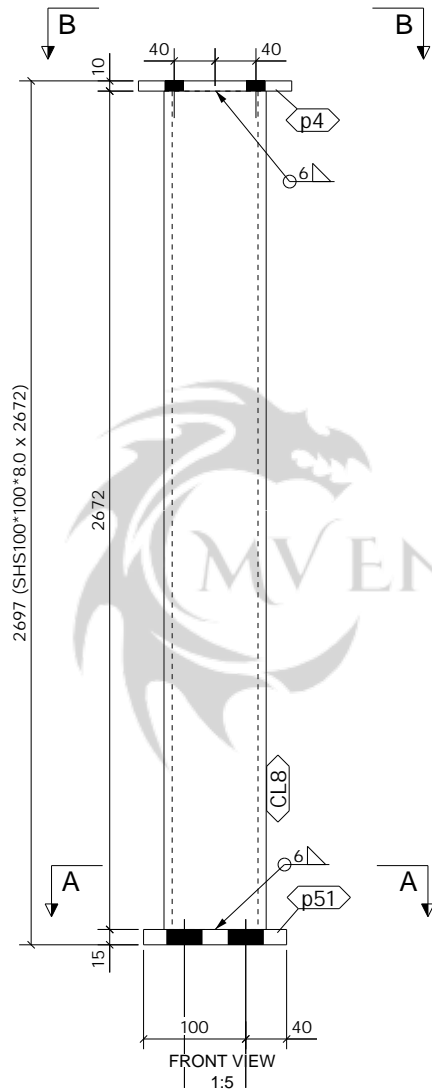
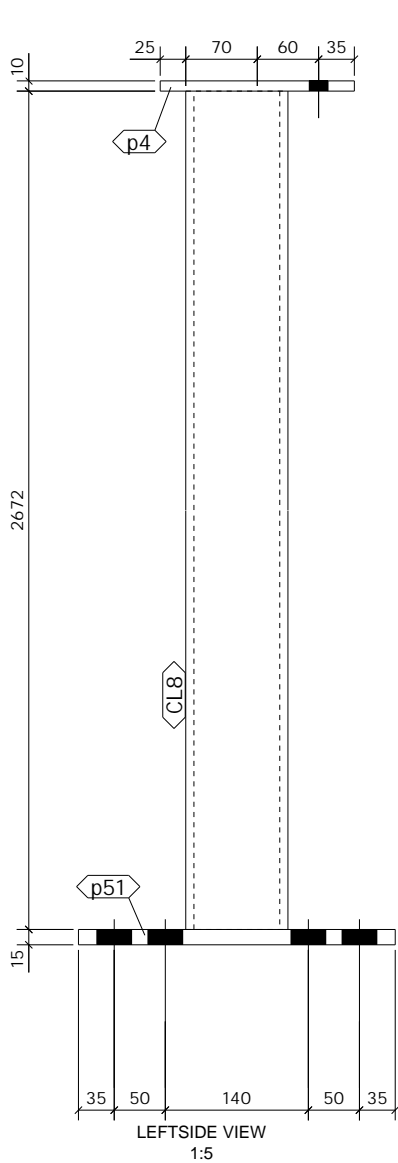

1 No. COLUMN

REQUIRED AS DRAWN MARKED CL8

SHOP MATERIAL LIST FOR 1 ASSEMBLY

Mark	Size	Grade	No.	Length (mm)	Area (m ²)	Weight (kg)
CL8	SHS100*100*8.0	S275	1	2672	1.072	61.7
p4	FLT10*150	S275	1	190	0.064	2.2
p51	FLT15*140	S275	1	310	0.100	5.1
				Total	1.236	69.1

GENERAL NOTES

All Holes to be 22 Dia UNO Slot hole length is to outside
All Welds to be 6 FW. UNO

All Steelwork Manufactured to:
BS EN 1090-2: Execution Class **EXC2** U.N.O.

FINISH **GALVANISED**

LOT **0** QTY **1**

PHASE **1** QTY **1**

FABRICATION STATUS

Sawn by: _____ Date: _____

Fabricated by: _____ Date: _____

Welded by: _____ Date: _____

Loaded by: _____ Date: _____

Checked by: _____ Date: _____

REV	DESCRIPTION	ISSUED FOR APPROVAL			
		By	Date	By	Date
A		PCS	25.01.2023	SK	25.01.2023
MARK		CREATED		CHECKED	

CLIENT: _____ DATE CREATED: 24.01.2023

PROJECT: Ebenezer Street DRAWN BY: PCS

CONTRACT NO: T8298 DRAWING NO: [CL.8] REV: A

ASSEMBLY / SUB ASSEMBLY STATUS	
1	THIS IS IT'S OWN ASSEMBLY

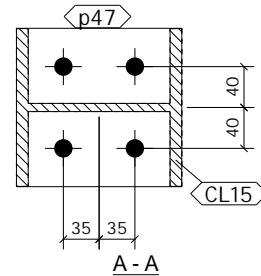
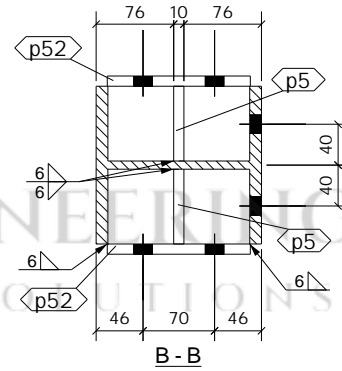
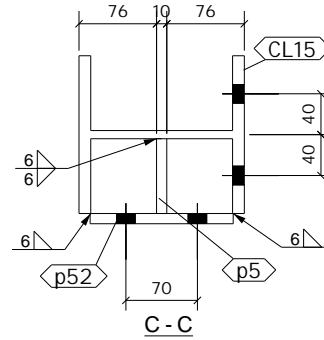
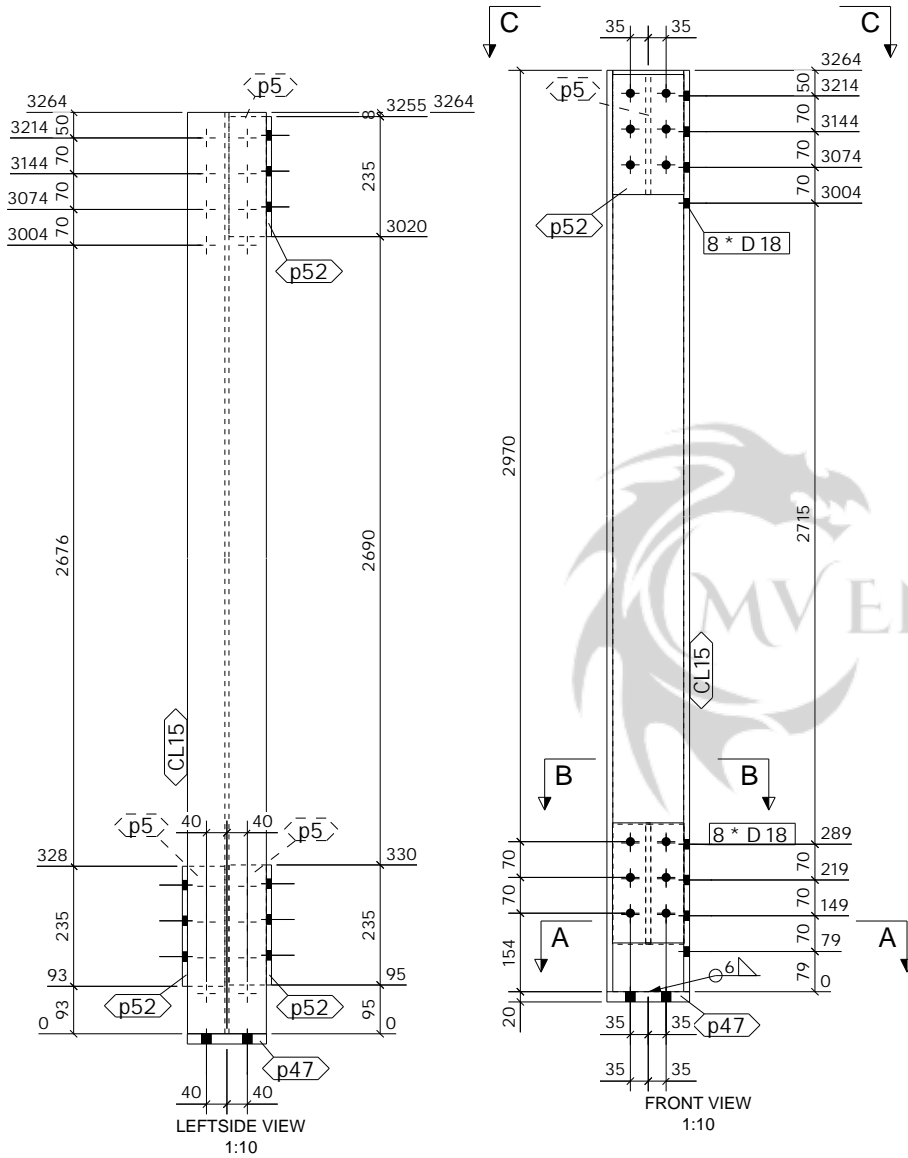

1 No. COLUMN

REQUIRED AS DRAWN MARKED CL9

SHOP MATERIAL LIST FOR 1 ASSEMBLY

Mark	Size	Grade	No.	Length (mm)	Area (m ²)	Weight (kg)
CL15	UC152*152*44	S275	1	3264	3.029	119.4
p5	PLT10*73.2	S275	3	235	0.122	4.1
p47	PLT20*155	S275	1	162	0.063	3.9
p52	FLT10*140	S275	3	235	0.220	7.7
Total					3.433	135.2

GENERAL NOTES

All Holes to be 22 Dia UNO Slot hole length is to outside
 All Welds to be 6 FW. UNO

All Steelwork Manufactured to:
 BS EN 1090-2: Execution Class EXC2 U.N.O.

FINISH S.B. & PRIME
 LOT 0 QTY 1
 PHASE 1 QTY 1

FABRICATION STATUS

Sawn by: _____ Date: _____
 Fabricated by: _____ Date: _____
 Welded by: _____ Date: _____
 Loaded by: _____ Date: _____
 Checked by: _____ Date: _____

REV	DESCRIPTION	ISSUED FOR APPROVAL			
		By	Date	By	Date
A		PCS	25.01.2023	SK	25.01.2023
MARK		CREATED		CHECKED	

CLIENT: Ebenezzer Street DATE CREATED: 24.01.2023

PROJECT: Ebenezzer Street DRAWN BY: PCS

CONTRACT NO: T8298 DRAWING NO: [CL.9] REV: A

ASSEMBLY / SUB ASSEMBLY STATUS	
1	THIS IS IT'S OWN ASSEMBLY

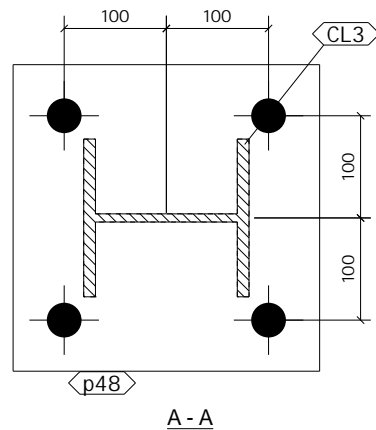
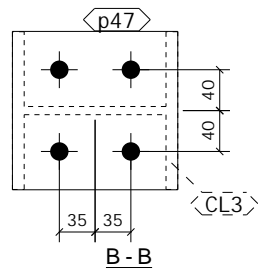
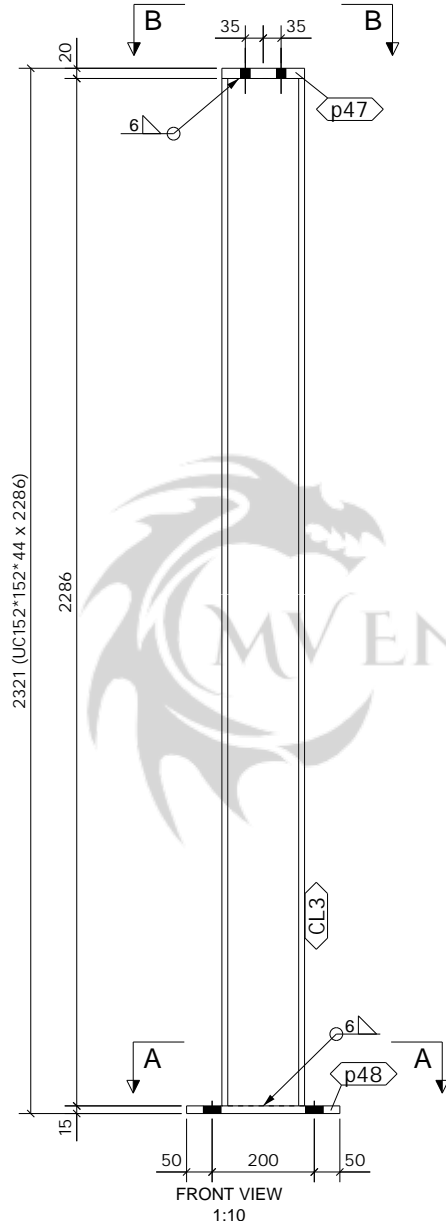
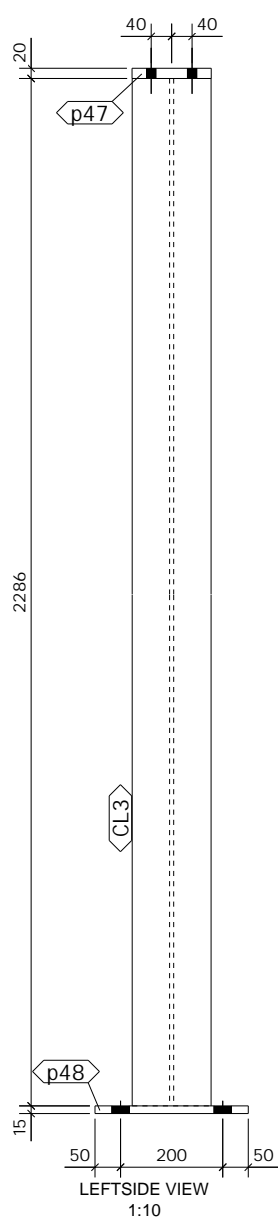

1 No. COLUMN

REQUIRED AS DRAWN MARKED CL10

SHOP MATERIAL LIST FOR 1 ASSEMBLY

Mark	Size	Grade	No.	Length (mm)	Area (m ²)	Weight (kg)
CL3	UC152*152*44	S275	1	2286	2.125	83.7
p47	PLT20*155	S275	1	162	0.063	3.9
p48	FLT15*300	S275	1	300	0.198	10.6
Total					2.385	98.2

GENERAL NOTES

All Holes to be 22 Dia UNO Slot hole length is to outside
 All Welds to be 6 FW. UNO

All Steelwork Manufactured to:
 BS EN 1090-2: Execution Class EXC2 U.N.O.

FINISH GALVANISED

LOT	0	QTY	1
PHASE	1	QTY	1

FABRICATION STATUS

Sawn by:	_____	Date:	_____
Fabricated by:	_____	Date:	_____
Welded by:	_____	Date:	_____
Loaded by:	_____	Date:	_____
Checked by:	_____	Date:	_____

A	ISSUED FOR APPROVAL	PCS	25.01.2023	SK	25.01.2023
		By	Date	By	Date
REV	DESCRIPTION	CREATED	CHECKED		

CLIENT: DATE CREATED: 24.01.2023

PROJECT: Ebenezer Street DRAWN BY: PCS

CONTRACT NO: T8298 DRAWING NO: [CL.10] REV: A

ASSEMBLY / SUB ASSEMBLY STATUS	
1	THIS IS IT'S OWN ASSEMBLY

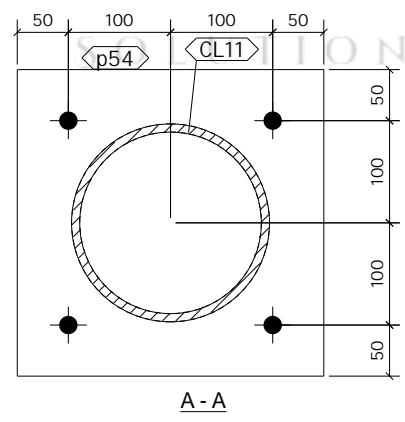
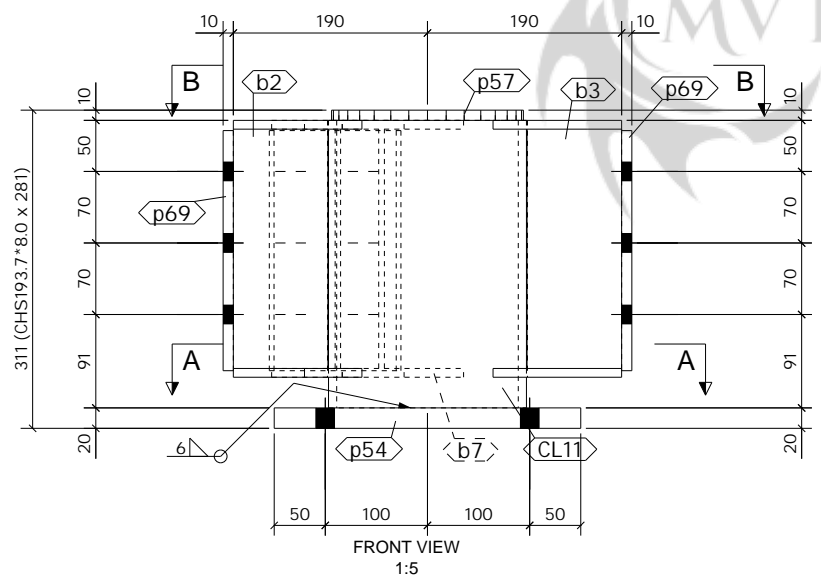
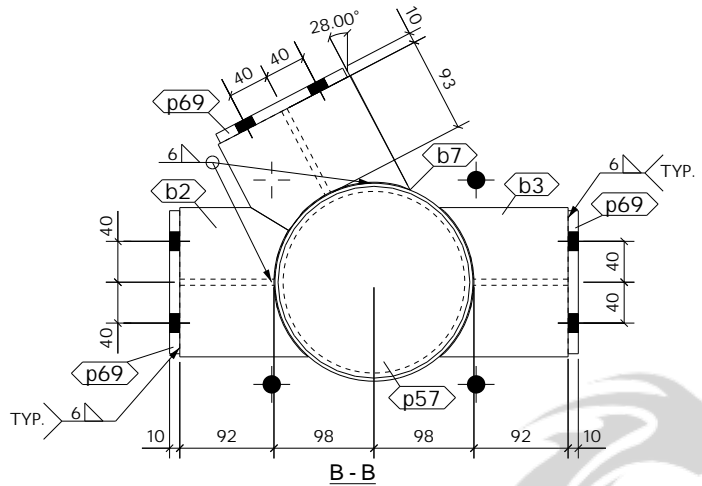

1 No. COLUMN

REQUIRED AS DRAWN MARKED CL11

SHOP MATERIAL LIST FOR 1 ASSEMBLY

Mark	Size	Grade	No.	Length (mm)	Area (m ²)	Weight (kg)
CL11	CHS193.7*8.0	S275	1	281	0.176	10.2
b2	UB254*146*31	S275	1	126	0.112	3.0
b3	UB254*146*31	S275	1	126	0.115	3.0
b7	UB254*146*31	S275	1	126	0.112	3.0
p54	FLT20*300	S275	1	300	0.204	14.1
p57	PLT10*186.8	S275	1	187	0.061	2.2
p69	FLT10*140	S275	3	235	0.220	7.7
Total					0.999	43.2

GENERAL NOTES

All Holes to be 22 Dia UNO Slot hole length is to outside
 All Welds to be 6 FW. UNO

All Steelwork Manufactured to:
 BS EN 1090-2: Execution Class **EXC2** U.N.O.

FINISH **GALVANISED**
 LOT 0 QTY 1
 PHASE 1 QTY 1

FABRICATION STATUS

Sawn by: _____ Date: _____
 Fabricated by: _____ Date: _____
 Welded by: _____ Date: _____
 Loaded by: _____ Date: _____
 Checked by: _____ Date: _____

A	ISSUED FOR APPROVAL	PCS	25.01.2023	SK	25.01.2023
		By	Date	By	Date
REV	DESCRIPTION	CREATED		CHECKED	

CLIENT: _____ **DATE CREATED:** 25.01.2023

PROJECT: Ebenezer Street **DRAWN BY:** PCS

CONTRACT NO: T8298 **DRAWING NO:** [CL.11] **REV:** A

ASSEMBLY / SUB ASSEMBLY STATUS	
1	THIS IS IT'S OWN ASSEMBLY

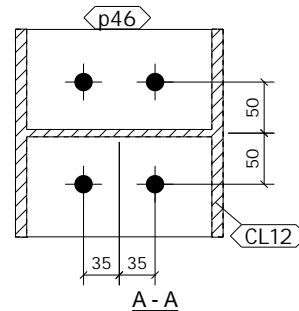
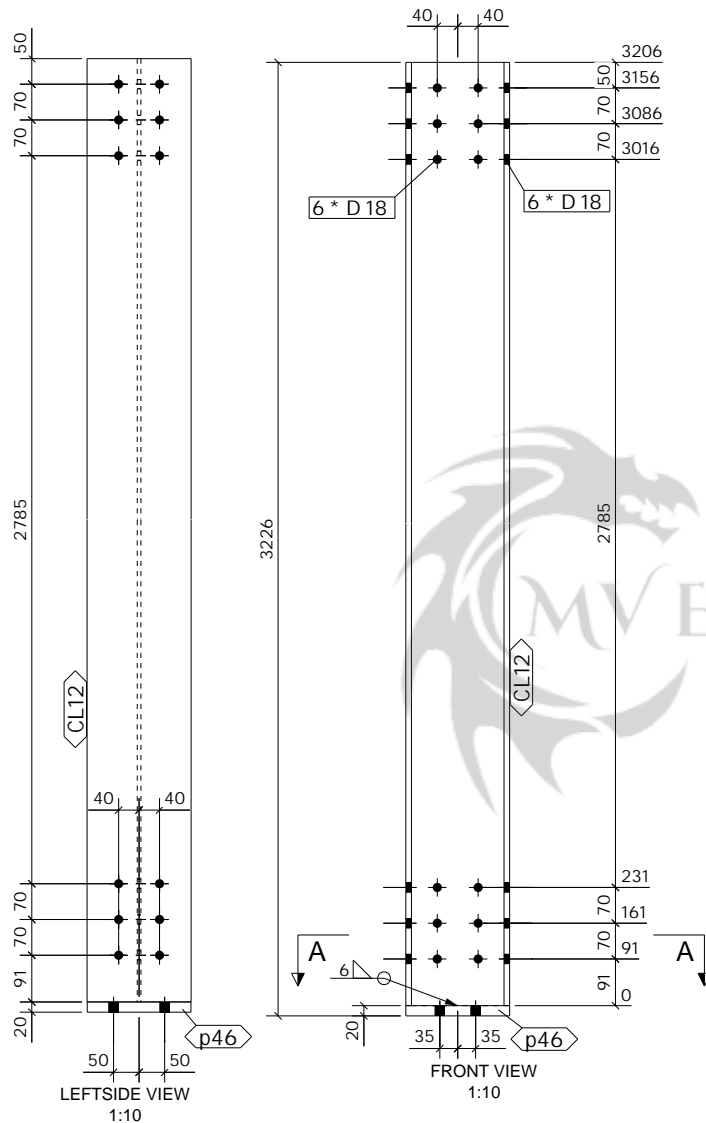

SHOP MATERIAL LIST FOR 1 ASSEMBLY

Mark	Size	Grade	No.	Length (mm)	Area (m ²)	Weight (kg)
CL12	UC203*203*46	S275	1	3206	3.880	145.6
p46	PLT20*203	S275	1	203	0.099	6.5
Total					3.979	152.1

GENERAL NOTES

All Holes to be **22** Dia UNO Slot hole length is to outside
 All Welds to be **6** FW. UNO

All Steelwork Manufactured to:
 BS EN 1090-2: Execution Class **EXC2** U.N.O.

FINISH **S.B. & PRIME**
 LOT **0** QTY **1**
 PHASE **1** QTY **1**

FABRICATION STATUS

Sawn by: _____ Date: _____
 Fabricated by: _____ Date: _____
 Welded by: _____ Date: _____
 Loaded by: _____ Date: _____
 Checked by: _____ Date: _____

REV	DESCRIPTION	ISSUED FOR APPROVAL			
		By	Date	By	Date
A		PCS	25.01.2023	SK	25.01.2023
MARK		CREATED		CHECKED	

CLIENT: _____ **DATE CREATED:** 24.01.2023

PROJECT: Ebenezer Street **DRAWN BY:** PCS

CONTRACT NO: T8298 **DRAWING NO:** [CL.12] **REV:** A

1 No. COLUMN

REQUIRED AS DRAWN MARKED CL12

ASSEMBLY / SUB ASSEMBLY STATUS	
1	THIS IS IT'S OWN ASSEMBLY

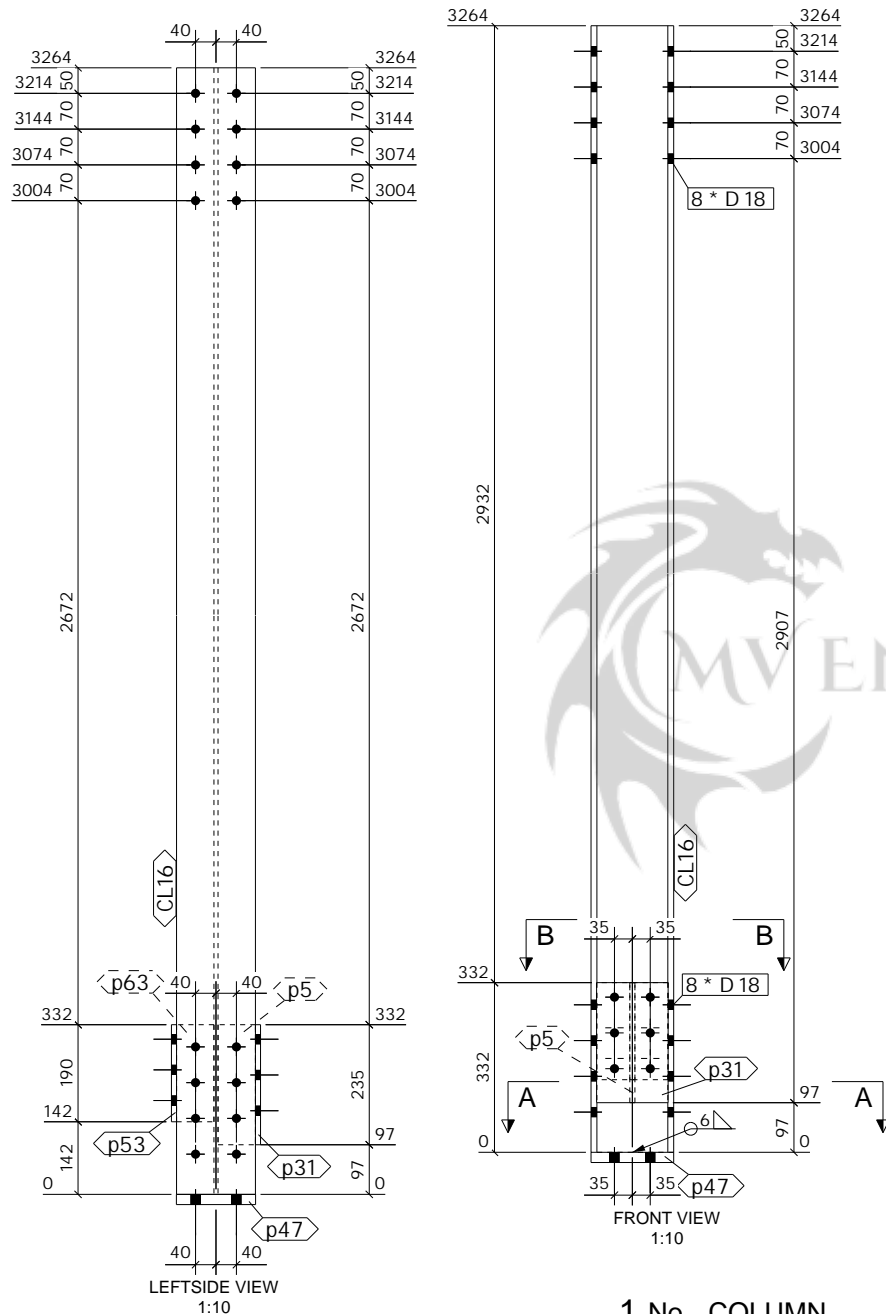

1 No. COLUMN

REQUIRED AS DRAWN MARKED CL13

ASSEMBLY / SUB ASSEMBLY STATUS	
1	THIS IS IT'S OWN ASSEMBLY

SHOP MATERIAL LIST FOR 1 ASSEMBLY

Mark	Size	Grade	No.	Length (mm)	Area (m ²)	Weight (kg)
CL16	UC152*152*44	S275	1	3264	3.029	119.4
p5	PLT10*73.2	S275	1	235	0.041	1.4
p31	FLT10*140	S275	1	235	0.073	2.6
p47	PLT20*155	S275	1	162	0.063	3.9
p53	FLT10*140	S275	1	190	0.060	2.1
p63	PLT10*73.2	S275	1	190	0.033	1.1
				Total	3.298	130.5

GENERAL NOTES

All Holes to be **22** Dia UNO Slot hole length is to outside
 All Welds to be **6** FW. UNO

All Steelwork Manufactured to:
 BS EN 1090-2: Execution Class **EXC2** U.N.O.

FINISH **S.B. & PRIME**
 LOT **0** QTY **1**
 PHASE **1** QTY **1**

FABRICATION STATUS

Sawn by: _____ Date: _____
 Fabricated by: _____ Date: _____
 Welded by: _____ Date: _____
 Loaded by: _____ Date: _____
 Checked by: _____ Date: _____

REV	DESCRIPTION	ISSUED FOR APPROVAL			
		By	Date	By	Date
A		PCS	25.01.2023	SK	25.01.2023
MARK		CREATED		CHECKED	

CLIENT: Ebenezzer Street **DATE CREATED:** 24.01.2023

PROJECT: Ebenezzer Street **DRAWN BY:** PCS

CONTRACT NO: T8298 **DRAWING NO:** [CL.13] **REV:** A

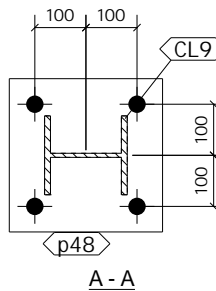
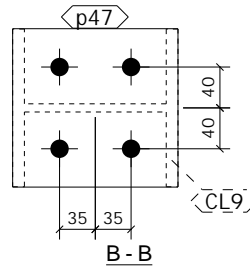
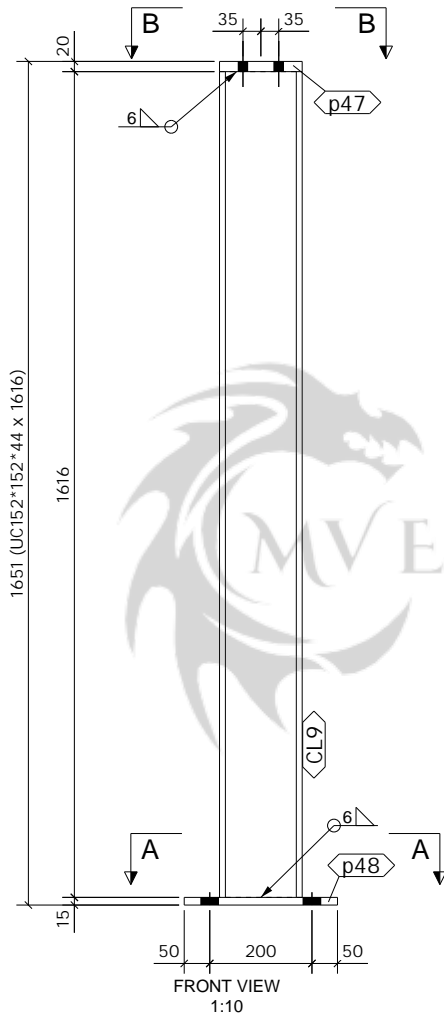
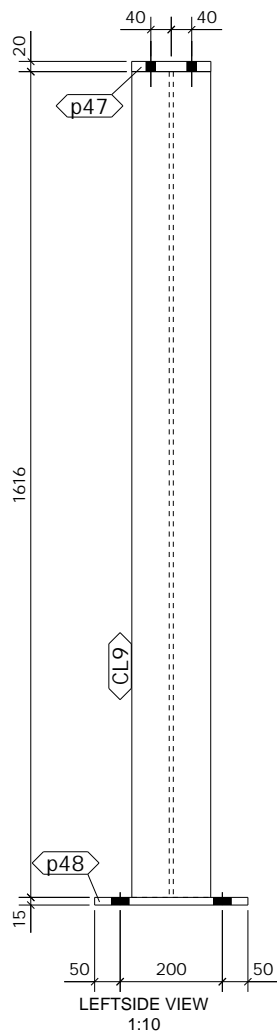

SHOP MATERIAL LIST FOR 1 ASSEMBLY

Mark	Size	Grade	No.	Length (mm)	Area (m ²)	Weight (kg)
CL9	UC152*152*44	S275	1	1616	1.505	59.1
p47	PLT20*155	S275	1	162	0.063	3.9
p48	FLT15*300	S275	1	300	0.198	10.6
Total					1.766	73.7

GENERAL NOTES

All Holes to be **22** Dia UNO Slot hole length is to outside
 All Welds to be **6** FW. UNO

All Steelwork Manufactured to:
 BS EN 1090-2: Execution Class **EXC2** U.N.O.

FINISH **GALVANISED**
 LOT **0** QTY **1**
 PHASE **1** QTY **1**

FABRICATION STATUS

Sawn by: _____ Date: _____
 Fabricated by: _____ Date: _____
 Welded by: _____ Date: _____
 Loaded by: _____ Date: _____
 Checked by: _____ Date: _____

A	ISSUED FOR APPROVAL	PCS	25.01.2023	SK	25.01.2023
REV		By	Date	By	Date
MARK	DESCRIPTION	CREATED	CHECKED		

CLIENT: _____ **DATE CREATED:** 24.01.2023

PROJECT: Ebenezer Street **DRAWN BY:** PCS

CONTRACT NO: T8298 **DRAWING NO:** [CL.14] **REV:** A

1 No. COLUMN

REQUIRED AS DRAWN MARKED CL14

ASSEMBLY / SUB ASSEMBLY STATUS	
1	THIS IS IT'S OWN ASSEMBLY

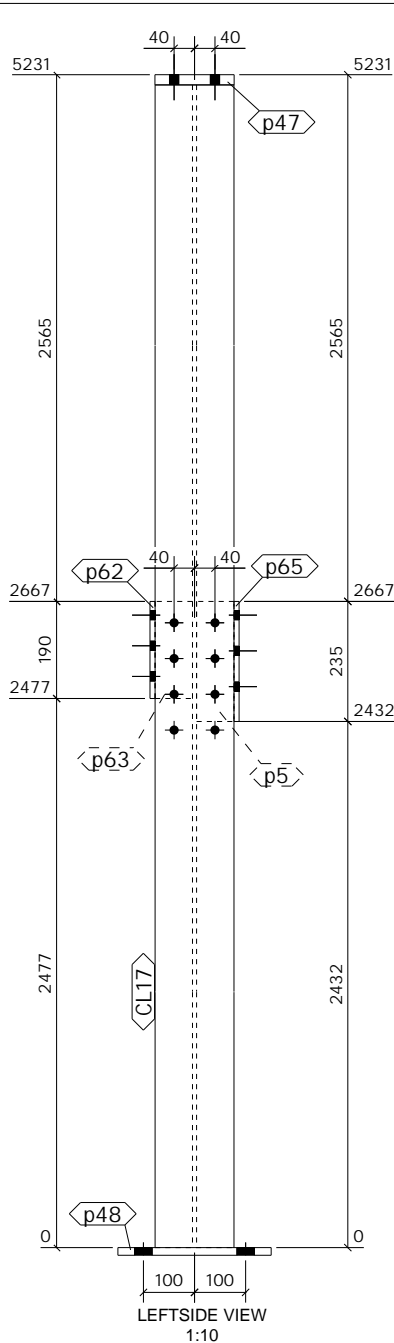

LEFTSIDE VIEW
1:10

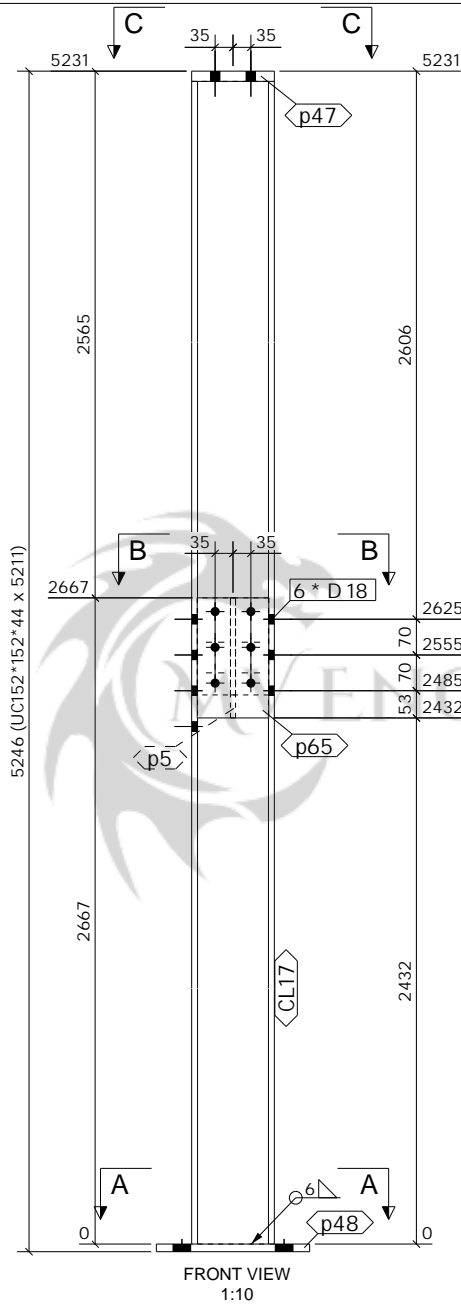

FRONT VIEW
1:10

1 No. COLUMN

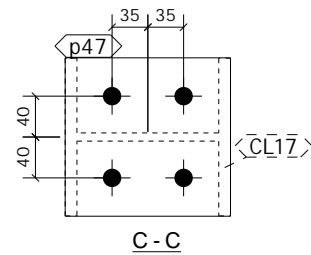

C - C

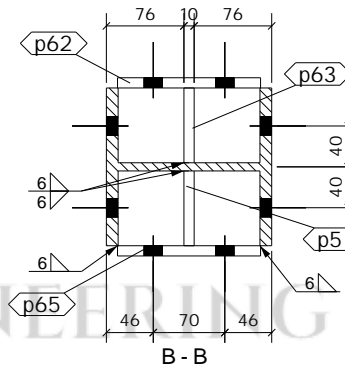

B - B

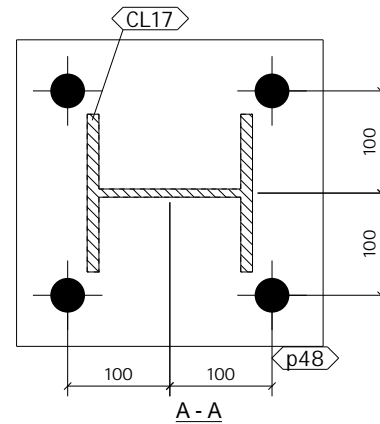

A - A

REQUIRED AS DRAWN MARKED CL15

SHOP MATERIAL LIST FOR 1 ASSEMBLY

Mark	Size	Grade	No.	Length (mm)	Area (m ²)	Weight (kg)
CL17	UC152*152*44	S275	1	5211	4.831	190.7
p5	PLT10*73.2	S275	1	235	0.041	1.4
p47	PLT20*155	S275	1	162	0.063	3.9
p48	FLT15*300	S275	1	300	0.198	10.6
p62	FLT10*140	S275	1	190	0.060	2.1
p63	PLT10*73.2	S275	1	190	0.033	1.1
p65	FLT10*140	S275	1	235	0.073	2.6
Total					5.298	212.3

GENERAL NOTES

All Holes to be 22 Dia UNO Slot hole length is to outside
All Welds to be 6 FW. UNO

All Steelwork Manufactured to:
BS EN 1090-2: Execution Class EXC2 U.N.O.

FINISH GALVANISED
LOT 0 QTY 1
PHASE 1 QTY 1

FABRICATION STATUS

Sawn by: _____ Date: _____
Fabricated by: _____ Date: _____
Welded by: _____ Date: _____
Loaded by: _____ Date: _____
Checked by: _____ Date: _____

REV	DESCRIPTION	ISSUED FOR APPROVAL			
		By	Date	By	Date
A		PCS	25.01.2023	SK	25.01.2023
MARK		CREATED		CHECKED	

CLIENT: Ebenezzer Street DATE CREATED: 24.01.2023

PROJECT: Ebenezzer Street DRAWN BY: PCS

CONTRACT NO: T8298 DRAWING NO: [CL.15] REV: A

ASSEMBLY / SUB ASSEMBLY STATUS	
1	THIS IS IT'S OWN ASSEMBLY

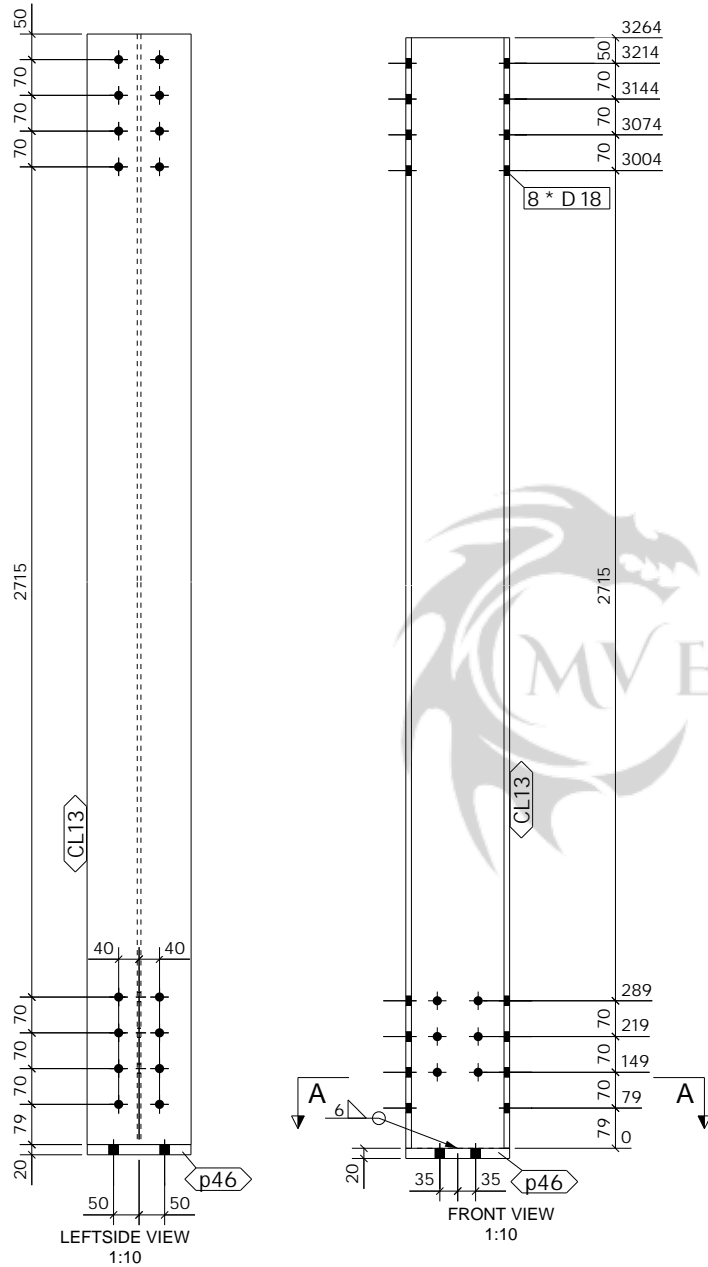

1 No. COLUMN

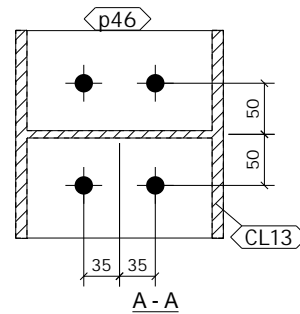

REQUIRED AS DRAWN MARKED CL16

SHOP MATERIAL LIST FOR 1 ASSEMBLY

Mark	Size	Grade	No.	Length (mm)	Area (m ²)	Weight (kg)
CL13	UC203*203*46	S275	1	3264	3.949	148.2
p46	PLT20*203	S275	1	203	0.099	6.5
Total					4.048	154.7

GENERAL NOTES

All Holes to be **22** Dia UNO Slot hole length is to outside
 All Welds to be **6** FW. UNO

All Steelwork Manufactured to:
 BS EN 1090-2: Execution Class **EXC2** U.N.O.

FINISH **S.B. & PRIME**
 LOT **0** QTY **1**
 PHASE **1** QTY **1**

FABRICATION STATUS

Sawn by: _____ Date: _____
 Fabricated by: _____ Date: _____
 Welded by: _____ Date: _____
 Loaded by: _____ Date: _____
 Checked by: _____ Date: _____

REV	DESCRIPTION	ISSUED FOR APPROVAL			
		By	Date	By	Date
A		PCS	25.01.2023	SK	25.01.2023
MARK		CREATED		CHECKED	

CLIENT: Ebenezer Street **DATE CREATED:** 24.01.2023

PROJECT: Ebenezer Street **DRAWN BY:** PCS

CONTRACT NO: T8298 **DRAWING NO:** [CL.16] **REV:** A

ASSEMBLY / SUB ASSEMBLY STATUS	
1	THIS IS IT'S OWN ASSEMBLY

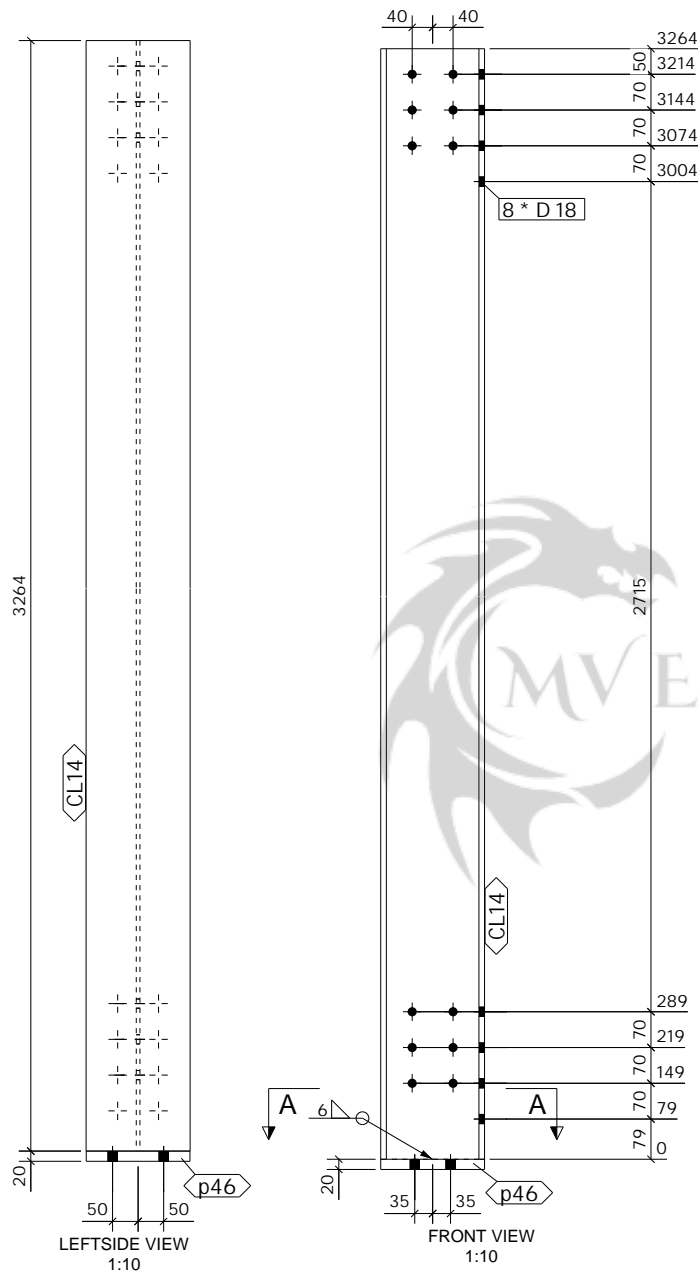

2 No. COLUMN

REQUIRED AS DRAWN MARKED CL17

SHOP MATERIAL LIST FOR 1 ASSEMBLY

Mark	Size	Grade	No.	Length (mm)	Area (m ²)	Weight (kg)
CL14	UC203*203*46	S275	1	3264	3.949	148.2
p46	PLT20*203	S275	1	203	0.099	6.5
Total					4.048	154.7

GENERAL NOTES

All Holes to be **22** Dia UNO Slot hole length is to outside
 All Welds to be **6** FW. UNO

All Steelwork Manufactured to:
 BS EN 1090-2: Execution Class **EXC2** U.N.O.

FINISH **S.B. & PRIME**
 LOT **0** QTY **2**
 PHASE **1** QTY **2**

FABRICATION STATUS

Sawn by: _____ Date: _____
 Fabricated by: _____ Date: _____
 Welded by: _____ Date: _____
 Loaded by: _____ Date: _____
 Checked by: _____ Date: _____

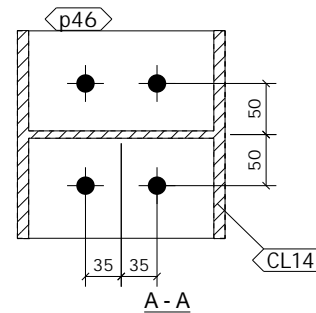

REV	DESCRIPTION	ISSUED FOR APPROVAL			
		By	Date	By	Date
A		PCS	25.01.2023	SK	25.01.2023
MARK		CREATED		CHECKED	

CLIENT: Ebenezer Street **DATE CREATED:** 24.01.2023

PROJECT: Ebenezer Street **DRAWN BY:** PCS

CONTRACT NO: T8298 **DRAWING NO:** [CL.17] **REV:** A

ASSEMBLY / SUB ASSEMBLY STATUS	
2	THIS IS IT'S OWN ASSEMBLY

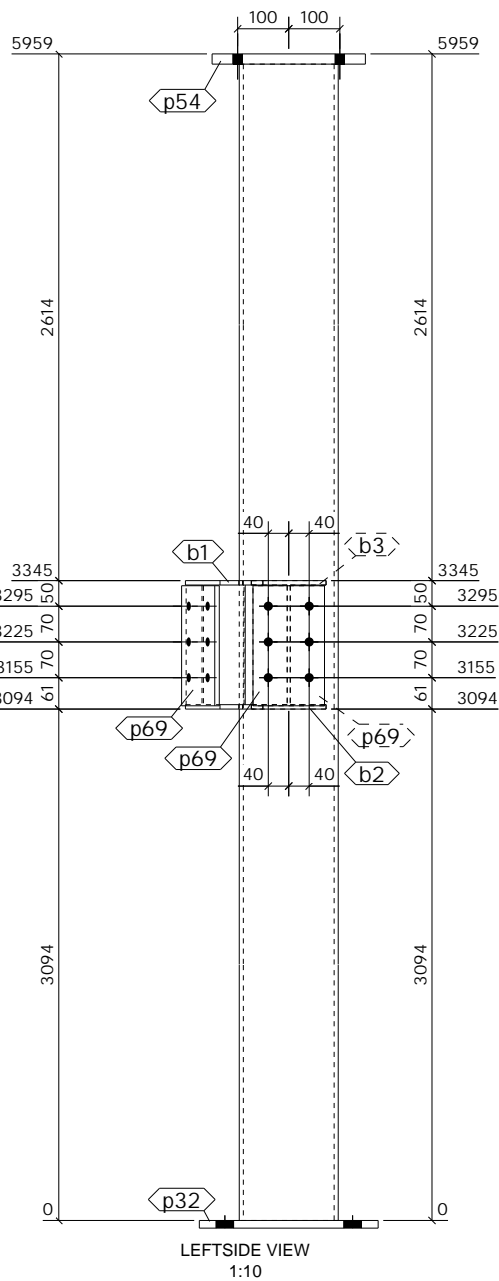

LEFTSIDE VIEW
1:10

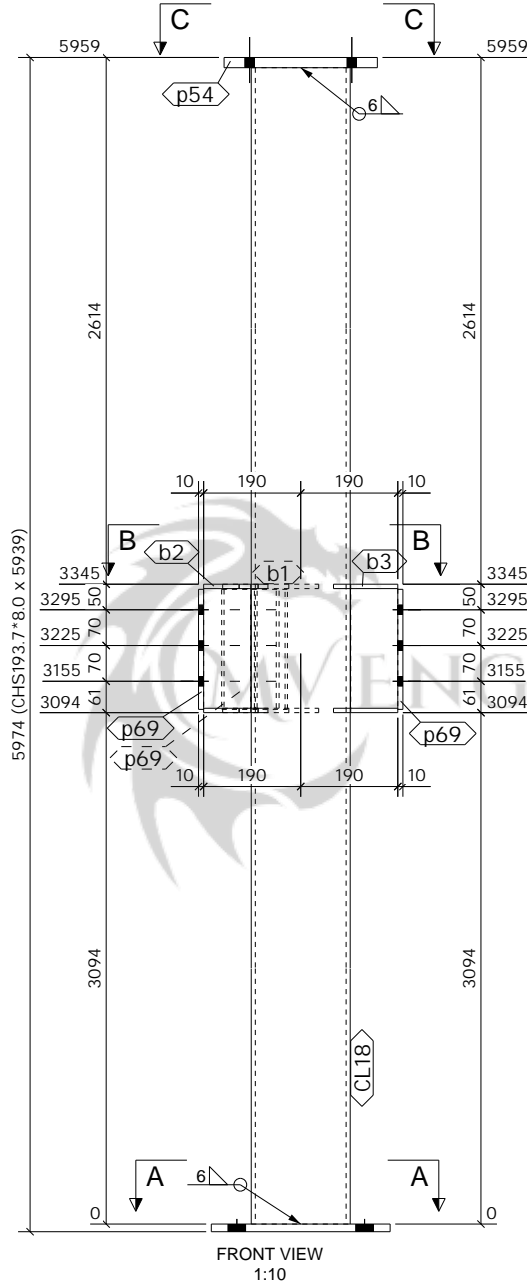

FRONT VIEW
1:10

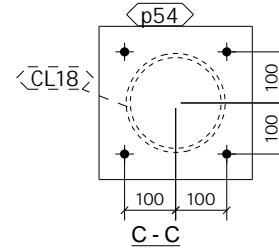

C - C

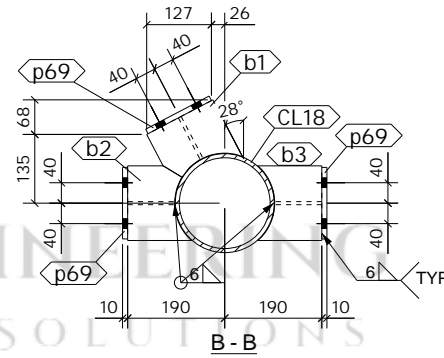

B - B

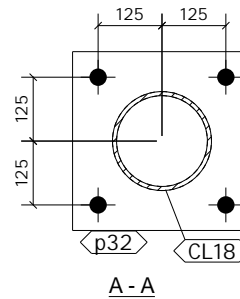

A - A

SHOP MATERIAL LIST FOR 1 ASSEMBLY

Mark	Size	Grade	No.	Length (mm)	Area (m ²)	Weight (kg)
CL18	CHS193.7*8.0	S275	1	5939	3.608	215.1
b1	UB254*146*31	S275	1	126	0.112	3.0
b2	UB254*146*31	S275	1	126	0.112	3.0
b3	UB254*146*31	S275	1	126	0.115	3.0
p32	FLT15*350	S275	1	350	0.266	14.4
p54	FLT20*300	S275	1	300	0.204	14.1
p69	FLT10*140	S275	3	235	0.220	7.7
				Total	4.636	260.4

GENERAL NOTES

All Holes to be 22 Dia UNO Slot hole length is to outside
All Welds to be 6 FW. UNO

All Steelwork Manufactured to:
BS EN 1090-2: Execution Class **EXC2** U.N.O.

FINISH **GALVANISED**
LOT **0** QTY **1**
PHASE **1** QTY **1**

FABRICATION STATUS

Sawn by: _____ Date: _____
Fabricated by: _____ Date: _____
Welded by: _____ Date: _____
Loaded by: _____ Date: _____
Checked by: _____ Date: _____

REV	MARK	DESCRIPTION	ISSUED FOR APPROVAL			
			By	Date	By	Date
A			PCS	25.01.2023	SK	25.01.2023
			CREATED		CHECKED	

CLIENT: Ebenezzer Street DATE CREATED: 25.01.2023

PROJECT: Ebenezzer Street DRAWN BY: PCS

CONTRACT NO: T8298 DRAWING NO: [CL.18] REV: A

ASSEMBLY / SUB ASSEMBLY STATUS	
1	THIS IS IT'S OWN ASSEMBLY

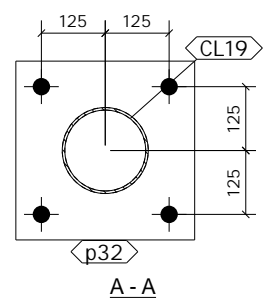
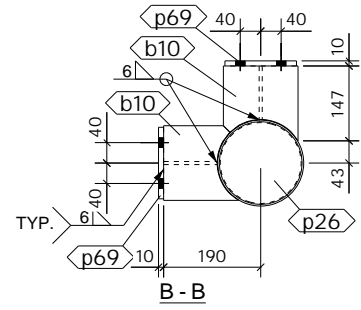
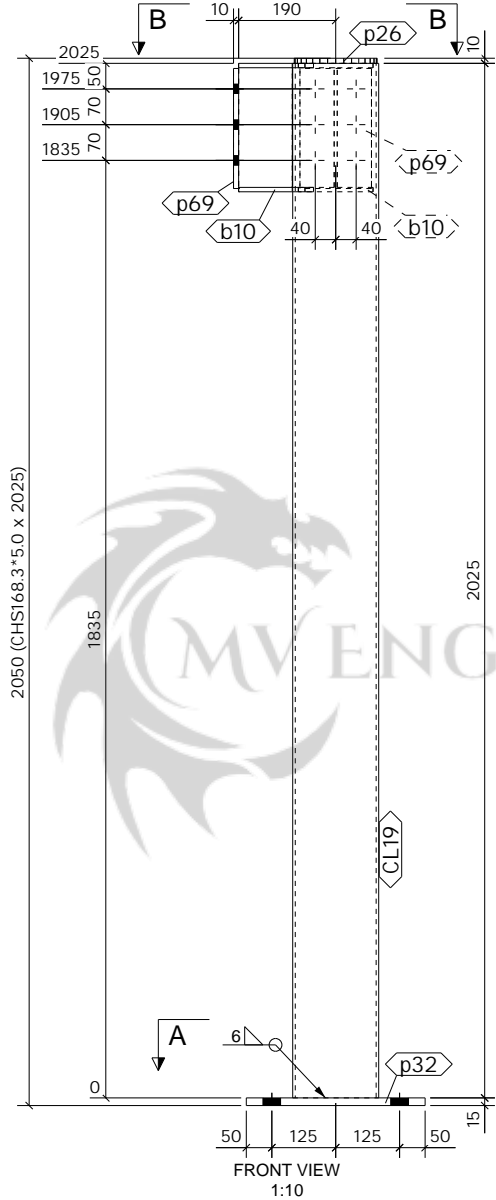
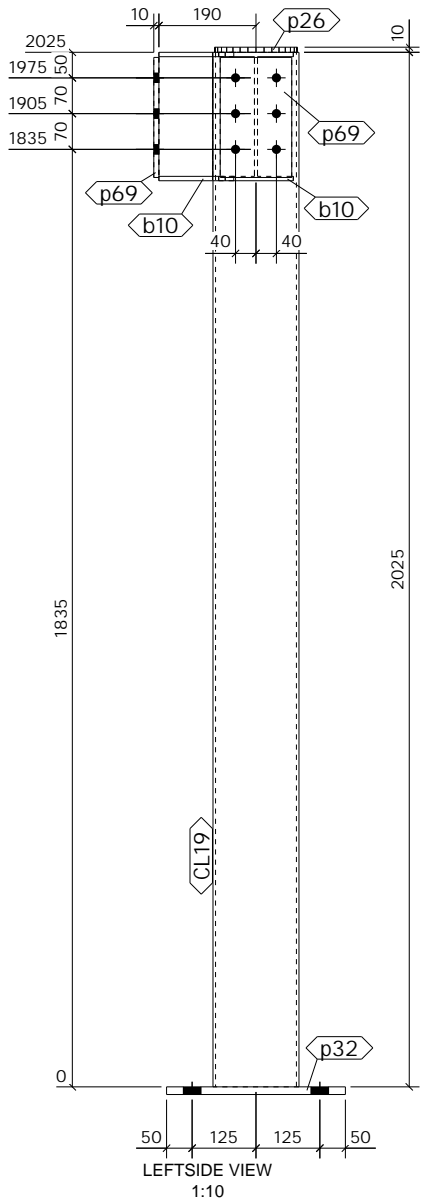

SHOP MATERIAL LIST FOR 1 ASSEMBLY

Mark	Size	Grade	No.	Length (mm)	Area (m ²)	Weight (kg)
CL19	CHS168.3*5.0	S275	1	2025	1.070	40.3
b10	UB254*146*31	S275	2	147	0.258	6.9
p26	PLT10*161.5	S275	1	162	0.046	1.6
p32	FLT15*350	S275	1	350	0.266	14.4
p69	FLT10*140	S275	2	235	0.147	5.2
Total					1.787	68.4

GENERAL NOTES

All Holes to be **22** Dia UNO Slot hole length is to outside
 All Welds to be **6** FW. UNO

All Steelwork Manufactured to:
 BS EN 1090-2: Execution Class **EXC2** U.N.O.

FINISH **GALVANISED**

LOT **0** QTY **1**
 PHASE **1** QTY **1**

FABRICATION STATUS

Sawn by: _____ Date: _____
 Fabricated by: _____ Date: _____
 Welded by: _____ Date: _____
 Loaded by: _____ Date: _____
 Checked by: _____ Date: _____

REV	MARK	DESCRIPTION	ISSUED FOR APPROVAL		CREATED		CHECKED	
			By	Date	By	Date	By	Date
A			PCS	25.01.2023	SK	25.01.2023		

CLIENT: Ebenezer Street
DATE CREATED: 25.01.2023
PROJECT: Ebenezer Street
DRAWN BY: PCS

CONTRACT NO: T8298
DRAWING NO: [CL.19]
REV: A

1 No. COLUMN REQUIRED AS DRAWN MARKED CL19

ASSEMBLY / SUB ASSEMBLY STATUS	
1	THIS IS IT'S OWN ASSEMBLY

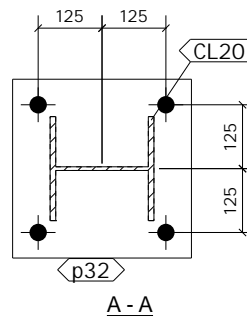
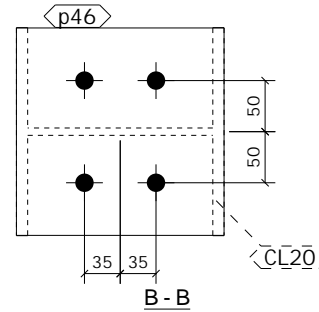
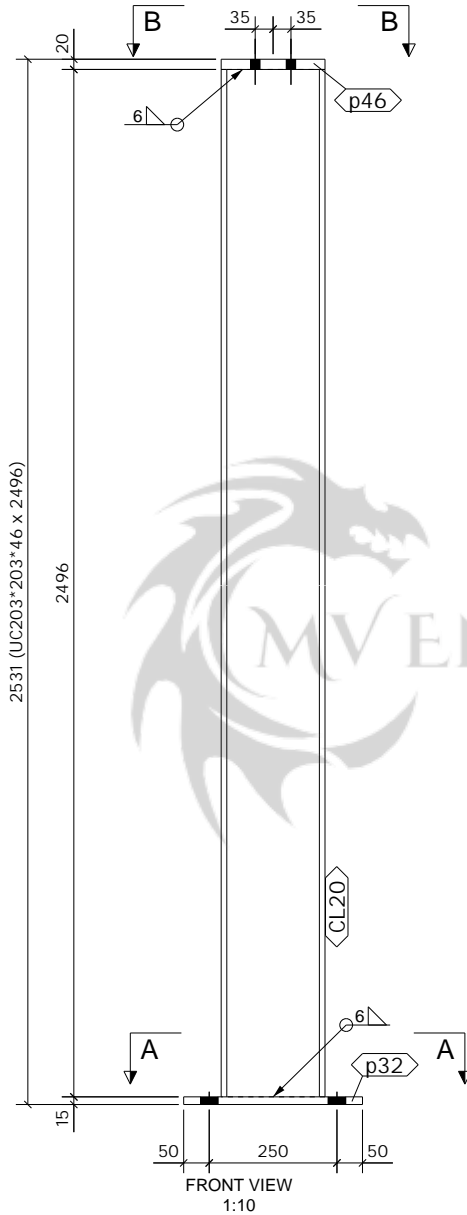
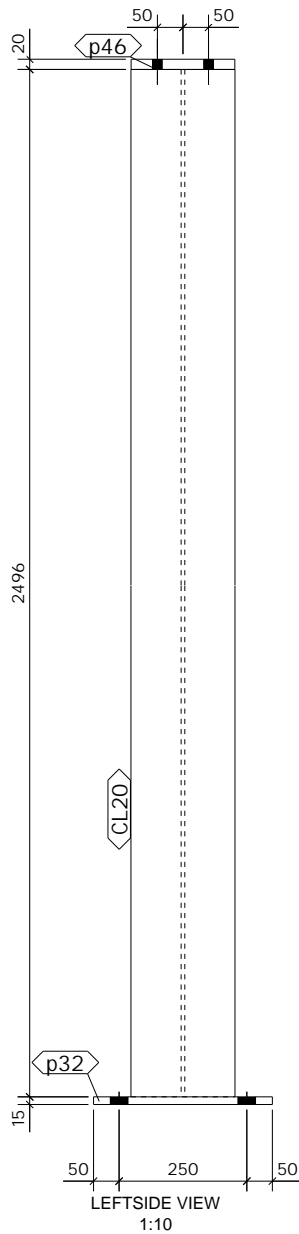

1 No. COLUMN

REQUIRED AS DRAWN MARKED CL20

SHOP MATERIAL LIST FOR 1 ASSEMBLY

Mark	Size	Grade	No.	Length (mm)	Area (m ²)	Weight (kg)
CL20	UC203*203*46	S275	1	2496	3.023	113.3
p32	FLT15*350	S275	1	350	0.266	14.4
p46	PLT20*203	S275	1	203	0.099	6.5
Total					3.388	134.2

GENERAL NOTES

All Holes to be 22 Dia UNO Slot hole length is to outside
 All Welds to be 6 FW. UNO

All Steelwork Manufactured to:
 BS EN 1090-2: Execution Class EXC2 U.N.O.

FINISH GALVANISED
 LOT 0 QTY 1
 PHASE 1 QTY 1

FABRICATION STATUS

Sawn by: _____ Date: _____
 Fabricated by: _____ Date: _____
 Welded by: _____ Date: _____
 Loaded by: _____ Date: _____
 Checked by: _____ Date: _____

REV	DESCRIPTION	ISSUED FOR APPROVAL			
		By	Date	By	Date
A		PCS	25.01.2023	SK	25.01.2023
MARK		CREATED		CHECKED	

CLIENT: Ebenezzer Street DATE CREATED: 24.01.2023

PROJECT: Ebenezzer Street DRAWN BY: PCS

CONTRACT NO: T8298 DRAWING NO: [CL.20] REV: A

ASSEMBLY / SUB ASSEMBLY STATUS	
1	THIS IS IT'S OWN ASSEMBLY

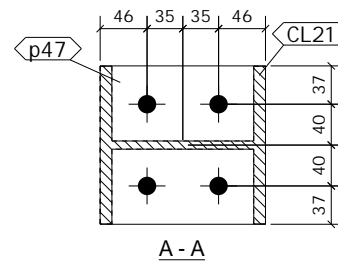
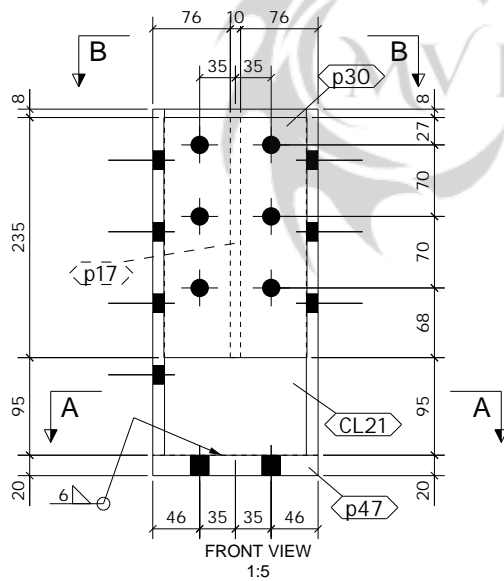
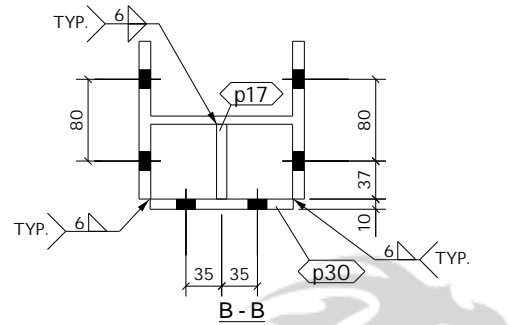

SHOP MATERIAL LIST FOR 1 ASSEMBLY

Mark	Size	Grade	No.	Length (mm)	Area (m ²)	Weight (kg)
CL21	UC152*152*44	S275	1	339	0.323	12.4
p17	PLT10*73.2	S275	1	235	0.041	1.4
p30	FLT10*140	S275	1	235	0.073	2.6
p47	PLT20*155	S275	1	162	0.063	3.9
Total					0.499	20.3

GENERAL NOTES

All Holes to be **22** Dia UNO Slot hole length is to outside
 All Welds to be **6** FW. UNO

All Steelwork Manufactured to:
 BS EN 1090-2: Execution Class **EXC2** U.N.O.

FINISH **GALVANISED**
 LOT **0** QTY **1**
 PHASE **1** QTY **1**

FABRICATION STATUS

Sawn by: _____ Date: _____
 Fabricated by: _____ Date: _____
 Welded by: _____ Date: _____
 Loaded by: _____ Date: _____
 Checked by: _____ Date: _____

A	ISSUED FOR APPROVAL	APPROVAL			
		PCS	25.01.2023	SK	25.01.2023
REV	DESCRIPTION	By	Date	By	Date
MARK	DESCRIPTION	CREATED	CHECKED		

CLIENT: _____ **DATE CREATED:** 25.01.2023

PROJECT: Ebenezer Street **DRAWN BY:** PCS

CONTRACT NO: T8298 **DRAWING NO:** [CL.21] **REV:** A

1 No. COLUMN

REQUIRED AS DRAWN MARKED CL21

ASSEMBLY / SUB ASSEMBLY STATUS	
1	THIS IS IT'S OWN ASSEMBLY

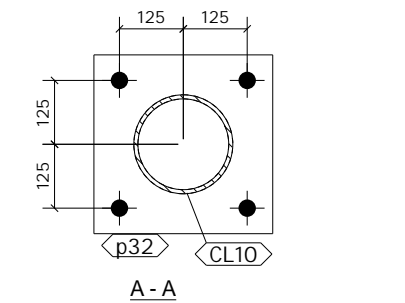
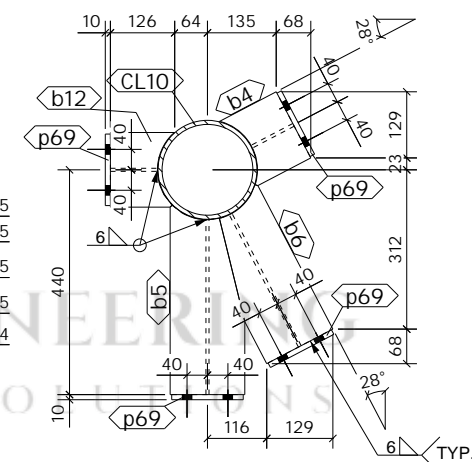
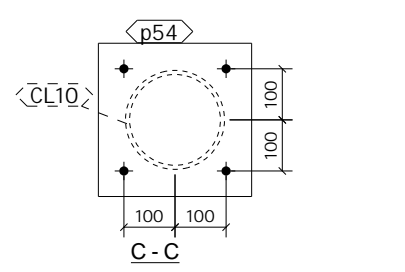
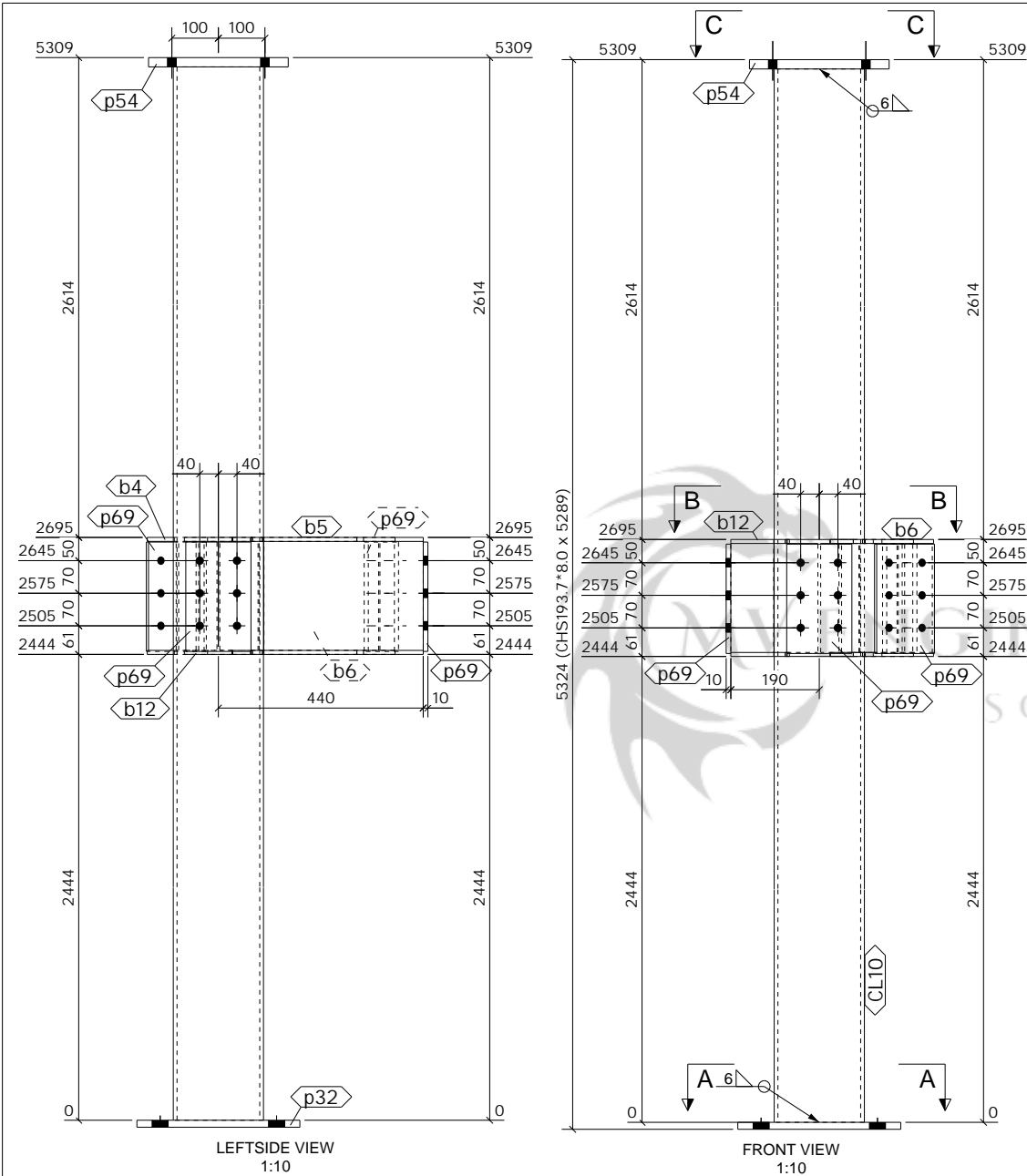

SHOP MATERIAL LIST FOR 1 ASSEMBLY						
Mark	Size	Grade	No.	Length (mm)	Area (m ²)	Weight (kg)
CL10	CHS193.7*8.0	S275	1	5289	3.214	191.6
b4	UB254*146*31	S275	1	125	0.115	3.0
b5	UB254*146*31	S275	1	371	0.359	10.0
b6	UB254*146*31	S275	1	321	0.306	8.4
b12	UB254*146*31	S275	1	126	0.115	3.0
p32	FLT15*350	S275	1	350	0.266	14.4
p54	FLT20*300	S275	1	300	0.204	14.1
p69	FLT10*140	S275	4	235	0.293	10.3
Total					4.871	254.9

GENERAL NOTES

All Holes to be **22 Dia UNO** Slot hole length is to outside
 All Welds to be **6 FW. UNO**

All Steelwork Manufactured to:
 BS EN 1090-2: Execution Class **EXC2** U.N.O.

FINISH **GALVANISED**

LOT **0** QTY **1**
 PHASE **1** QTY **1**

FABRICATION STATUS

Sawn by: _____ Date: _____
 Fabricated by: _____ Date: _____
 Welded by: _____ Date: _____
 Loaded by: _____ Date: _____
 Checked by: _____ Date: _____

A	ISSUED FOR APPROVAL			
	PCS	Date	SK	Date
REV	By	Date	By	Date
MARK	DESCRIPTION	CREATED	CHECKED	

CLIENT: Ebenezzer Street
DATE CREATED: 25.01.2023
PROJECT: Ebenezzer Street
DRAWN BY: PCS
CONTRACT NO: T8298
DRAWING NO: [CL.22]
REV: A

ASSEMBLY / SUB ASSEMBLY STATUS	
1	THIS IS IT'S OWN ASSEMBLY

1 No. COLUMN REQUIRED AS DRAWN MARKED CL22

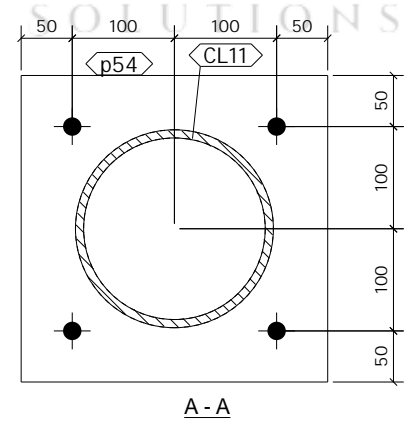
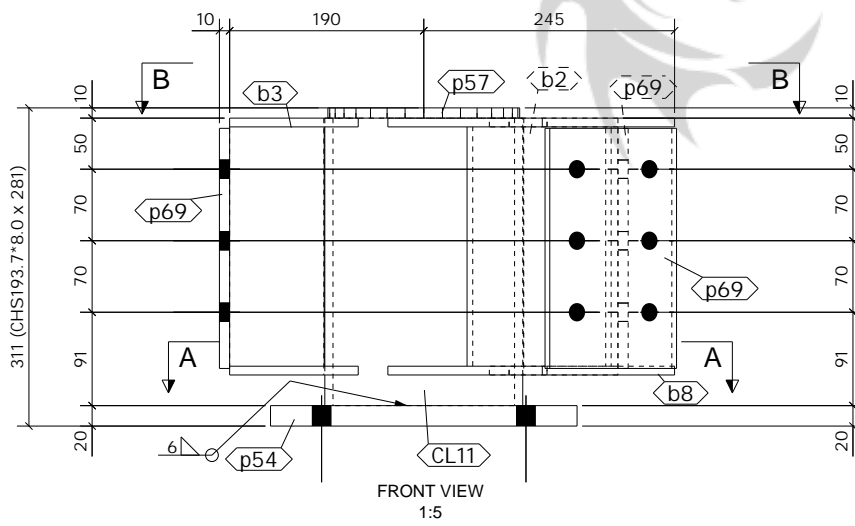
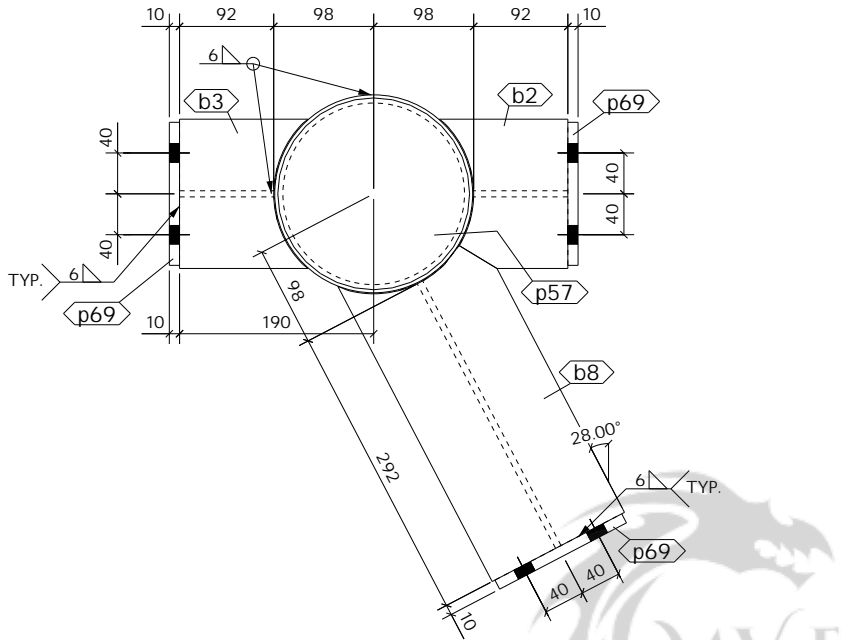

1 No. COLUMN

REQUIRED AS DRAWN MARKED CL23

SHOP MATERIAL LIST FOR 1 ASSEMBLY

Mark	Size	Grade	No.	Length (mm)	Area (m ²)	Weight (kg)
CL11	CHS193.7*8.0	S275	1	281	0.176	10.2
b2	UB254*146*31	S275	1	126	0.112	3.0
b3	UB254*146*31	S275	1	126	0.115	3.0
b8	UB254*146*31	S275	1	326	0.327	9.1
p54	FLT20*300	S275	1	300	0.204	14.1
p57	PLT10*186.8	S275	1	187	0.061	2.2
p69	FLT10*140	S275	3	235	0.220	7.7
Total					1.214	49.4

GENERAL NOTES

All Holes to be 22 Dia UNO Slot hole length is to outside
 All Welds to be 6 FW. UNO

All Steelwork Manufactured to:
 BS EN 1090-2: Execution Class **EXC2** U.N.O.

FINISH **GALVANISED**
 LOT 0 QTY 1
 PHASE 1 QTY 1

FABRICATION STATUS

Sawn by: _____ Date: _____
 Fabricated by: _____ Date: _____
 Welded by: _____ Date: _____
 Loaded by: _____ Date: _____
 Checked by: _____ Date: _____

REV	MARK	DESCRIPTION	ISSUED FOR APPROVAL		CREATED		CHECKED	
			By	Date	By	Date	By	Date
A			PCS	25.01.2023	SK	25.01.2023		

CLIENT: _____ **DATE CREATED:** 25.01.2023

PROJECT: Ebenezer Street **DRAWN BY:** PCS

CONTRACT NO: T8298 **DRAWING NO:** [CL.23] **REV:** A

ASSEMBLY / SUB ASSEMBLY STATUS	
1	THIS IS IT'S OWN ASSEMBLY